



# SnowDogg<sup>®</sup> CM















## OWNER'S MANUAL

## Table of Contents

1. Warnings/Vehicle Application .....	pg. 2
2. About the plow .....	pg. 3
3. Registration Information/Website .....	pg. 3
4. Snowplow Mounting/Dismounting .....	pg. 4
5. Mechanical Installation .....	pg. 5-6
6. Harness Installation .....	pg. 7-9
7. Storage and Maintenance.....	pg. 10
8. Parts Diagram and BOM .....	pg. 11-14
a. Lift Frame .....	pg. 11
b. Moldboard.....	pg. 12
c. Hydraulic Power Unit .....	pg. 13
9. Troubleshooting .....	pg. 15-16
10. Snow Plowing Tips .....	pg. 16

## CM INSTALLATION/REFERENCE MANUAL

 <b>WARNING</b>
Many newer trucks are equipped with air bags. <b>DO NOT</b> under any circumstances disable or remove or relocate any sensors or other components related to the operation of the air bags.
 <b>WARNING</b>
Always follow the vehicle manufacturers recommendations relating to snowplow installation. For recommended vehicle models refer to the SnowDogg Application Chart and Selection Guide.
 <b>WARNING</b>
Vehicles equipped with air bags are designed such that the air bags will be activated in a frontal collision equivalent to hitting a solid barrier (such as a wall) at approximately 14 mph or more, or, roughly speaking, a frontal perpendicular collision with a parked car or truck of similar size at approximately 28 mph or more. Careless or high speed driving while plowing snow, which results in vehicle decelerations equivalent to or greater than the air bag deployment threshold described above, would deploy the air bag.
 <b>WARNING</b>
Make sure plow is properly attached before moving vehicle.
 <b>WARNING</b>
Do not move plow while servicing or place body parts between or under plow parts while moving plow.

 <b>WARNING</b>
When transporting, position plow so as not to block vision or plow headlights.
 <b>WARNING</b>
<b>DO NOT</b> change blade position when traveling.
 <b>WARNING</b>
<b>DO NOT</b> exceed 40 mph when transporting plow.
 <b>WARNING</b>
Do not exceed 10 mph when plowing.
 <b>WARNING</b>
Always lower blade when vehicle is not in use.
 <b>WARNING</b>
Read this manual carefully before operating this snowplow.
 <b>CAUTION</b>
Vehicle application recommendations are based on the following:
<ul style="list-style-type: none"> <li>• The vehicle with the snowplow installed must comply with applicable Federal Motor Vehicle Safety Standards (FMVSS).</li> <li>• The vehicle with the snowplow installed must comply with the vehicle manufacturer's stated gross vehicle and axle weight ratings (found on the driver-side door corner post of the vehicle) and the front and rear weight distribution ratio. In some cases, rear ballast may be required to comply with these requirements.</li> <li>• In some cases there may be additional limitations and requirements.</li> <li>• Available capacity decreases as the vehicle is loaded with cargo or other truck equipment, or snowplow accessories are installed.</li> <li>• If there is uncertainty as to whether available capacity exists, the actual vehicle as configured must be weighed.</li> </ul>



## WELCOME!

Congratulations on your purchase of a SnowDogg® plow! The SnowDogg® plow by Buyers Products is a heavy-duty, professional grade plow built for your toughest plowing applications. By using this manual for maintenance and safety instructions, you can be sure to optimize the life of your plow.

Your dealer can provide expert assistance and service and is the first line of support. They have first hand knowledge of your plow and the conditions in your area.

Be sure to register your plow after purchase at [www.buyersproducts.com/support/productregistration](http://www.buyersproducts.com/support/productregistration). Registration is required to activate your two year warranty. The required information is shown on the Registration Data Sheet.

### **REGISTRATION DATA SHEET** **Owner's Information**

**Name:** \_\_\_\_\_

**Company:** \_\_\_\_\_

**Address:** \_\_\_\_\_

**Phone:** \_\_\_\_\_

**Fax:** \_\_\_\_\_

**E-mail:** \_\_\_\_\_

**Purchased From:** \_\_\_\_\_

**Purchase Date:** \_\_\_\_\_

**Plow Model:** \_\_\_\_\_

**Plow Serial#:** \_\_\_\_\_

**HPU Serial #:** \_\_\_\_\_

**Truck Model:** \_\_\_\_\_

**Truck Year:** \_\_\_\_\_

*Register your plow at [www.buyersproducts.com](http://www.buyersproducts.com) to activate your two year warranty.*

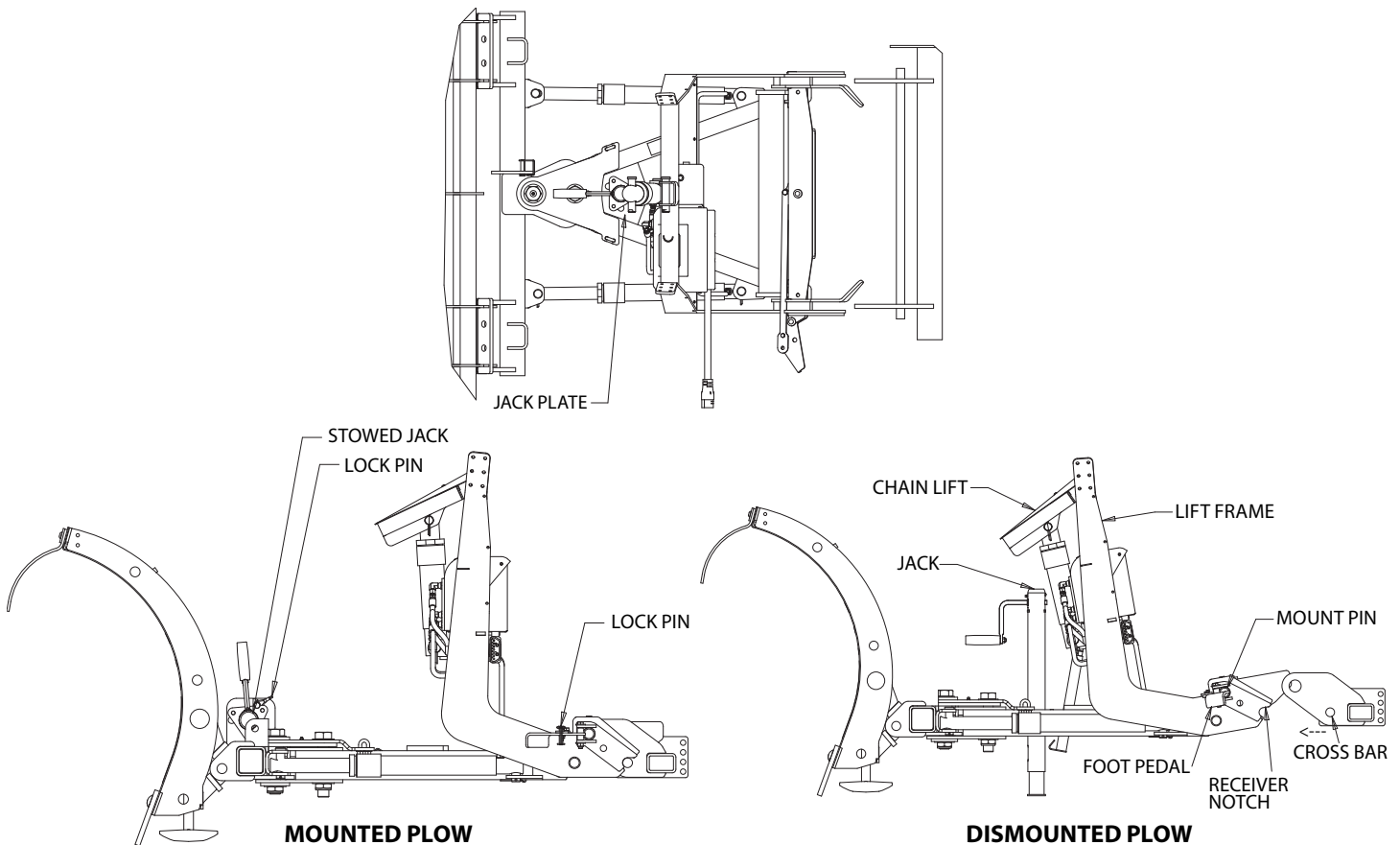

## MOUNT/DISMOUNT INSTRUCTIONS

### Snowplow Mounting *(fig. above)*

- 1.** Check that the pins are fully retracted. The foot pedal should be pushed towards the truck and will lock in the retracted position.
- 2.** Drive in to the plow so that the cross bar on the mount engages with the receiver notch on the plow. Depending on the plow height the jack may need to be lowered or raised to fully engage.
- 3.** Pull the foot pedals away from the truck to release the pins.
- 4.** Push up on the lift frame to engage the pins. The gold pin will be visible to verify full connection. Insert the lock pin (or padlock) through the foot pedal and pedal linkage.
- 5.** Retract the jack enough to allow its removal. Rotate the jack to disengage from the jack mount plate.
- 6.** Stow the jack on the sector mounted stow plate and insert the lock pin. The jack may also be stored in the truck for added theft prevention.
- 7.** Connect both the lighting & hydraulic connectors.

### Snowplow Dismount *(fig. above)*

- 1.** Put the plow in float by holding the down button for 1 second.
- 2.** Press down on the chain lift to retract the lift cylinder. The chain must have slack for ease of plow removal.
- 3.** Install the jack into the jack mount plate. This will raise the lift frame prop.
- 4.** Extend the jack enough to remove weight from the plow mount pins.
- 5.** Push on the foot pedals and raise the lift frame simultaneously. The pins will retract and the lift frame will rotate forward to rest on the lift frame prop.
- 6.** Disconnect the lighting and hydraulic connectors
- 7.** Back away from the snowplow



## INSTALLATION

SnowDogg® snowplows are shipped almost completely assembled to minimize the amount of time from box to plowing. The illustrations are representative only and may differ from your hardware. Please see the parts diagrams for specific part numbers.

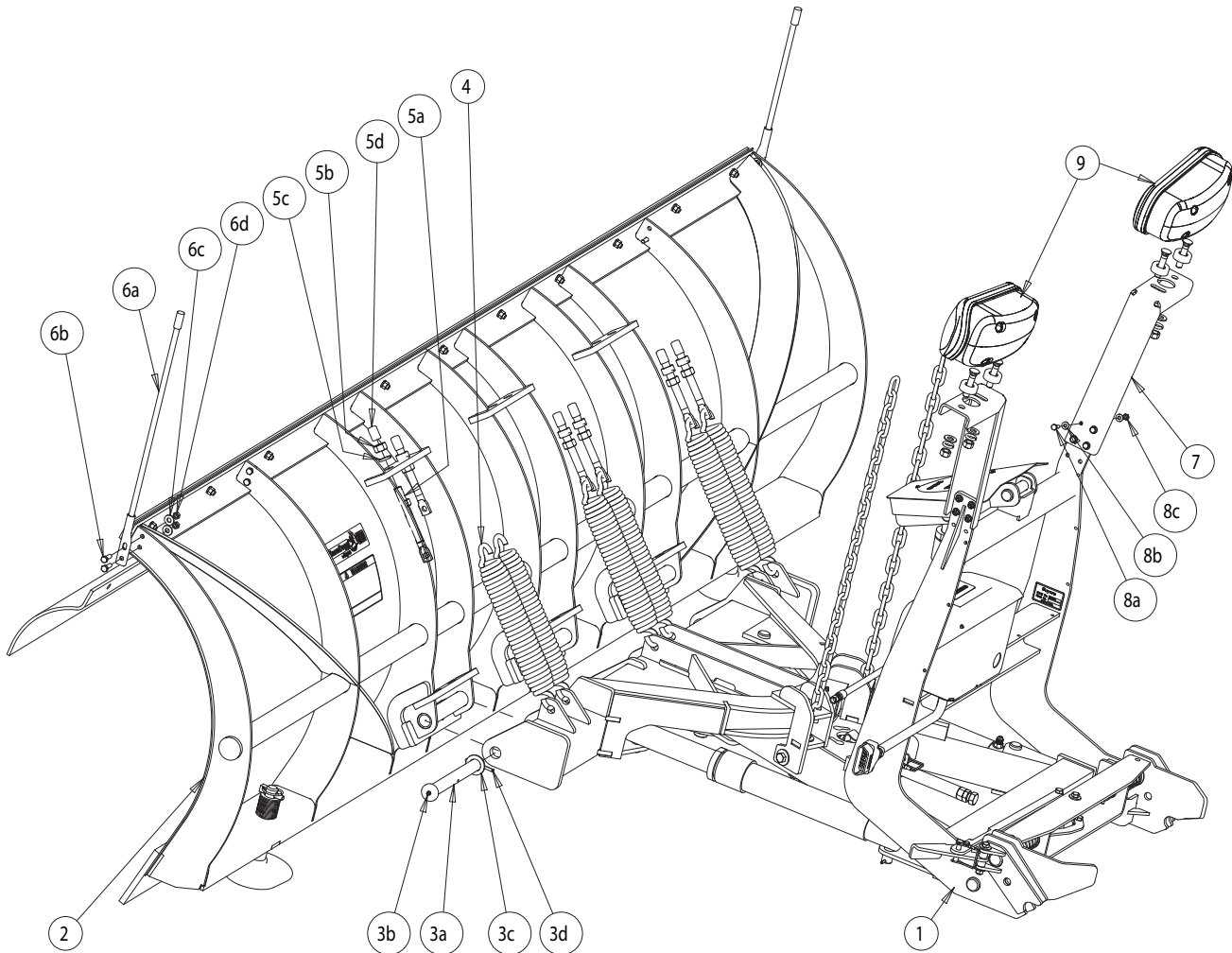

ITEM	QTY.	PART NO.	DESCRIPTION
<b>1</b>	<b>1</b>		<b>LIFT FRAME ASSEMBLY</b>
		16017001	CM Lift Frame
		16017021	CM Lift Frame - No Hydraulics
<b>2</b>	<b>1</b>		<b>MOLDBOARD ASSEMBLY</b>
		16020820	CM100 Moldboard w/ Deflector
<b>3</b>	<b>1</b>	<b>16101130</b>	<b>TRIP PIN HARDWARE KIT</b>
	3a		Trip Pin
	3b		Grease Fitting, 1/4-28
	3c		Washer, Flat, 1", ZN
	3d		Pin, Cotter, 1/4 x 2, ZN
<b>4</b>	<b>6</b>	<b>16101200</b>	<b>TRIP SPRING</b>
<b>5</b>	<b>1</b>	<b>16101230</b>	<b>TRIP SPRING KIT</b>
	5a		Eyebolt, 5/8-11 x 8
	5b		Nut, 5/8-11, ZN
	5c		Washer, Lock, 5/8 ZN
	5d		Cap, Black Vinyl

ITEM	QTY.	PART NO.	DESCRIPTION
<b>6</b>	<b>1</b>	<b>16122120</b>	<b>BLADE GUIDE KIT</b>
	6a		Blade Guide, Orange, 26"
	6b		Screw, Cap Hex 5/16-18 x 1, ZN
	6c		Washer, 5/16 Flat, ZN
	6d		Nut, Nylock, 5/16-18, ZN
<b>7</b>	<b>2</b>	<b>16111510</b>	<b>LIGHT BRACKETS</b>
<b>8</b>	<b>1</b>	<b>16111512</b>	<b>LIGHT HARDWARE KIT</b>
	8a		Screw, Cap Hex 1/4-20 x 1-1/4 ZN
	8b		Washer, Flat 1/4 ZN
	8c		Nut, Nylock, 1/4-20 ZN
<b>9</b>	<b>1</b>	<b>16160700A</b>	<b>HALOGEN LIGHT KIT (SOLD SEPARATELY)</b>
<b>9</b>	<b>1</b>	<b>16160800</b>	<b>LED LIGHT KIT (SOLD SEPARATELY)</b>

## **Snowplow Assembly**

- 1.** Attach the moldboard to the lift frame kit using the trips pins, washers, and cotter pins as shown. Check that the moldboard rotates freely around the trip pins.
- 2.** Install the trips springs using the trip spring hardware kit (eyebolt, 2x nuts, washer, rubber cap). Tension the springs until the coils are approximately .030" apart. A playing card serves as an adequate measuring device. It is important that all springs be at the same tension.
- 3.** Install the snow deflector (if desired) by loosening the fasteners on the top of the moldboard. The deflector fits between the black painted retainer strip & the stainless steel skin. It may be necessary to clamp the skin in place to allow insertion of the deflector. It is **NOT NECESSARY** to remove the fasteners completely.
- 4.** Install the blade guides using the included hardware kit.
- 5.** The shoes as installed have been adjusted for shipping & may need to be readjusted for proper plowing height.
- 6.** Install the lights with the light kit hardware. Do not route the plow side light harness yet as the Passenger and Driver side light connection will vary depending on the truck side installation. Do not tighten the light hardware yet, as they will need to be aimed.
- 7.** The plow may now be set into mounting configuration – install the jack and level the plow to the proper height for mounting to the truck.
- 8.** Grease all greasable fittings (trip pins & king bolt).

## **VEHICLE SPECIFIC MOUNT INSTALLATION**

- 1.** Mount the truck undercarriage as shown in the undercarriage installation instructions. As with the plow, all the fasteners should be checked on a regular basis.

## **VEHICLE SPECIFIC HEADLIGHT ADAPTER INSTALLATION**

- 1.** It may be necessary to remove vehicle headlights to access the truck light harness connectors.
- 2.** Install the vehicle specific headlight adapters per included installation instructions.
- 3.** Be sure to route wires and harnesses away from hot surfaces or moving parts.

***For safety reasons, the blade drops very slowly on the plow as shipped. To adjust the drop speed of the blade use a flat blade screwdriver and turn the lowering speed adjustment on the front of the hydraulic power unit counter clockwise. Turn it clockwise to slow the blade drop speed. Do this only while the blade is dropped, and tighten the jam nut after adjusting.***

## HARNESS INSTALLATION

The SnowDogg® has two separate harnesses for ease of installation and troubleshooting – a control harness and a light harness. They can be mounted separately. In the case of trucks with central hydraulics or existing auxiliary lights, either harness can be omitted without affecting the functionality of the other system.

### CAUTION

Keep all connectors greased with dielectric grease on a regular basis to minimize corrosion & potential damage or wear to the pins. It is critical that all electrical connections be tight and secure. Loose connections on the plow circuit can cause overheating, component failure, or intermittent operation.

## Control Harness

The plow side control harness has been preinstalled. The truck side control harness is routed through the grill, by the battery, and through the firewall to the controller. It is preferable when possible to keep the plow connector on the drivers side to make mount/dismount easier and faster.

## Control Harness Diagram

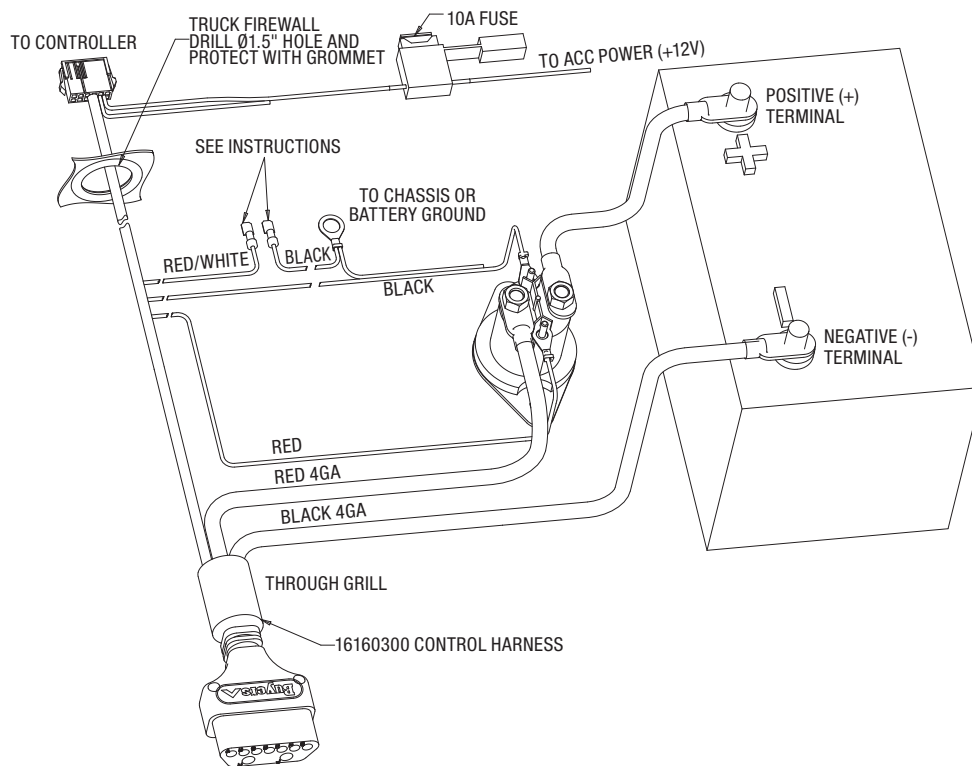

**1.** Route the CONTROL HARNESS through the truck grill, by the battery, and through the firewall. Some trucks will require drilling a  $\varnothing 1.50$ " hole through the firewall, while some will have holes provided (usually plugged). Check your truck Owner's Manual for details. If the hole is drilled it is critical that a grommet be used to prevent damage to the wire harness.

**2.** Mount the MOTOR RELAY in a convenient and secure location on the battery side of the vehicle using the included self tapping screws.

**3.** The small RED WIRE from the CONTROL HARNESS is connected to a small terminal of the MOTOR RELAY.

**4.** The small BLACK WIRE from the CONTROL HARNESS has two leads – one is connected to the other small terminal of the MOTOR RELAY. The other is connected directly to vehicle/chassis ground.

5. The large (4 gage) BLACK WIRE on the CONTROL HARNESS must be connected directly to the NEGATIVE (-) battery terminal. A BATTERY TERMINAL ADAPTER may be required.
6. The large (4 gage) RED WIRE on the CONTROL HARNESS is connected to one of the large terminals on the MOTOR RELAY.
7. The shorter red BATTERY CABLE is used to connect the other large terminal of the MOTOR RELAY with the POSITIVE (+) terminal on the battery. A BATTERY TERMINAL ADAPTER may be required.
8. The CONTROLLER CONNECTOR is routed through the firewall. Wait to complete RELAY HARNESS installation before further steps.
9. Connect the handheld controller and locate in a convenient location for the operator using the included mounting bracket or Velcro.
10. Male spade connectors on the BLACK and RED/WHITE wires will be connected to the LIGHT HARNESS in the next step.

### Light Harness Diagram

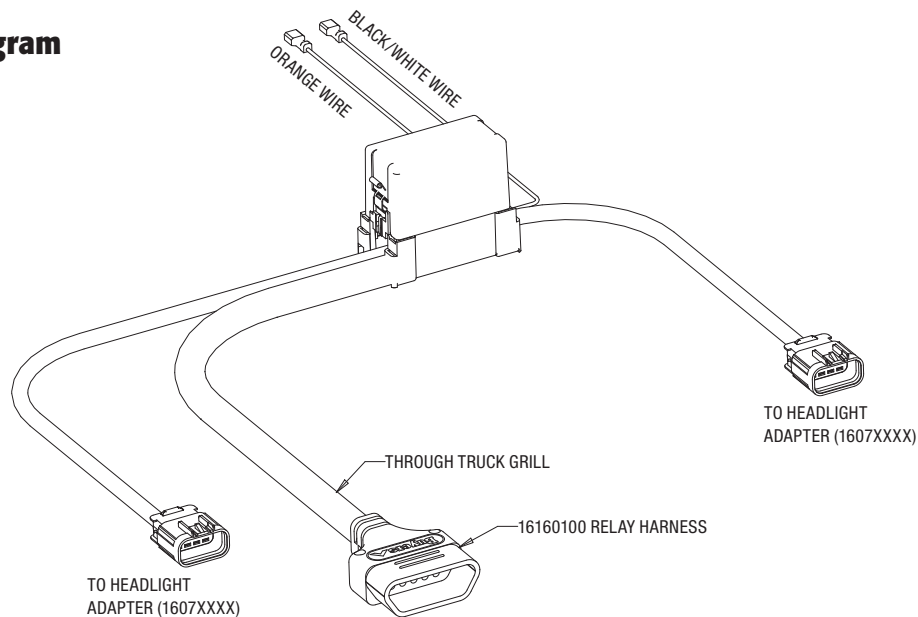

### Light Harness

1. Route the RELAY HARNESS through the grill (drivers side preferably) and place the RELAY MODULE close to either the drivers or passenger side headlight (whichever is convenient).
2. A VEHICLE SPECIFIC HEADLIGHT ADAPTER for your plow should be installed between the OEM HARNESS and HEADLIGHT on both the passenger and driver sides. The BROWN wire from the adapter should be spliced into the PARKING light circuit. The PURPLE wire from your adapter should be spliced into the TURN signal circuit.
3. Route and connect the 8-pin connectors on the RELAY HARNESS to the VEHICLE SPECIFIC HEADLIGHT ADAPTERS. There is a LONG and SHORT cable on the RELAY HARNESS. The LONG cable is for the far side of the vehicle. Both CABLES are identical. LEFT and RIGHT turn signals will be determined prior to routing the LIGHT HARNESS on the plow.
4. The ORANGE and BLACK/WHITE wires on the RELAY HARNESS are connected to the RED/WHITE and BLACK wires on the CONTROL HARNESS. Connect them as shown below – see the application guide for specific information on your vehicle. In the case of a standard ground vehicle (switched hot), connect the wires as shown below for standard configuration. In the case of a switched ground vehicle, locate the gray wire with male/female disconnected fittings (already connected). Disconnect the two halves. The male quick connect end of the wire will not be used and may be taped off. The female end will be connected to the RED/WHITE wire from the



16160300 harness. Connect the other wires as shown. It is recommended that heat shrink tubing be put over these connections once complete to seal against corrosion.

5. Connect the FUSED POWER LINE to an OEM approved +12V IGNITION source (10A).



### Light Aiming Diagram

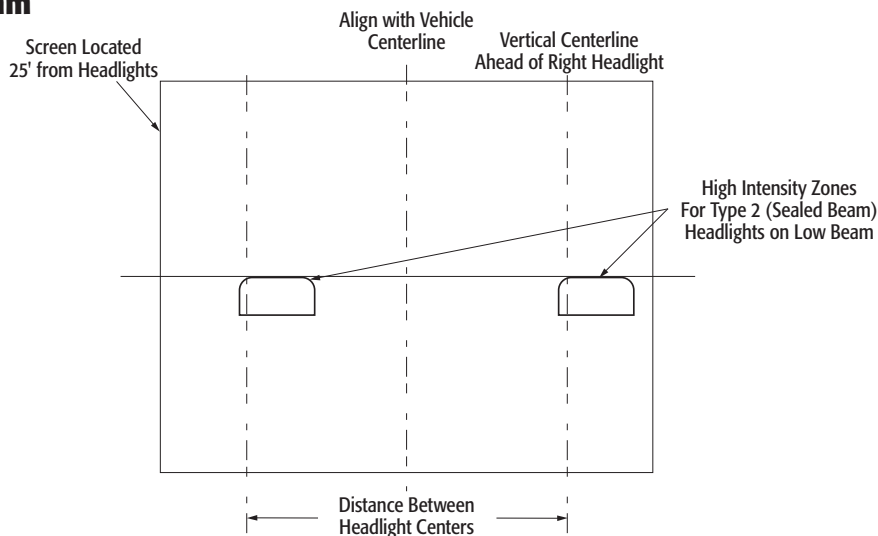

### Light Aiming

1. Place the vehicle on a level surface 25 feet in front of a matte-white screen, such as a white wall or garage door.
2. The snowplow should be mounted, with the blade raised in transport position.
3. Check that the truck is in normal operating condition with no flat tires, failed suspension components, and no passengers.
4. Mark the vertical centerline of the vehicle headlights on the screen (a line matching the height the of headlights from the ground). Mark the horizontal centerline of the vehicle headlights on the screen (lines matching the headlight center to center distance).
5. The high intensity zone of the low beams should be just below the horizontal line and the right of the vertical lines (see diagram above). Adjust the headlight aim as required.

**NOTE: Snowplow installers must certify that installation conforms to federal motor vehicle safety standards.** Your plow and truck are now ready for operation. The hydraulic system has been filled at the factory and should be fully operational. It is possible that agitation due to the shipping has introduce some air into the oil. When operating the plow for the first time some oil may exit the vent (by the coils). This should stop once the plow is cycled and operational. *Check all plow and light functions. If something is not working correctly, reread the installation directions to make sure a step was not missed and check the schematics.*

## **STORAGE**

1. Before disconnecting the plow from your vehicle, fully compress the lift cylinder
2. Disconnect the plow from your vehicle
3. Coat all electrical connection points with dielectric grease
4. Repair/touch up any chipped paint or rusted areas
5. Apply a coat of oil or grease to all exposed chrome (on angle and lift cylinders)
6. Grease all grease fittings on trip pins and king pin

## **REMOVAL FROM STORAGE**

1. Check all fasteners and hydraulic fittings for tightness.
2. Replace any cracked hydraulic hoses
3. Coat all electrical connection points with dielectric grease
4. Connect plow to vehicle

## **MAINTENANCE**

The SnowDogg® line of plows has been simply designed for reliable service. In order to ensure the reliability of your plow, observe the following maintenance items and regularly inspect:

- Fasteners and retaining devices for proper installation and tightness.
- Hydraulic cylinders for damage, pitting or leakage
- Hydraulic hoses for wear, damage or leakage. Replace any damaged hose.
- All electrical connections for corrosion – apply dielectric grease as required
- Cutting edge wear
- Plow shoe wear
- Greasable fittings (2x trip pins and king pin)

## **HYDRAULIC SYSTEM**

- All SnowDogg® plows use SnowDogg® brand Low-Temperature Hydraulic Fluid (P/N 16150010) available from SnowDogg® dealers.
- The reservoir should be filled through the top port until oil reaches the top port.
- Recheck and tighten all fittings and valves every season or as necessary. Vibration due to normal use can cause fittings to loosen.
- Loctite or Teflon tape should not be used on any fittings or hoses. The only plugs where pipe sealant may be used are the reservoir plugs.
- The reservoir should be drained and refilled every season to ensure that the oil remains free of water and contaminants. If contaminants are known to be present, it is recommended that the reservoir be removed and cleaned.

**With proper maintenance and care your SnowDogg plow will provide years of trouble free service!**

**Lift Frame Diagram**

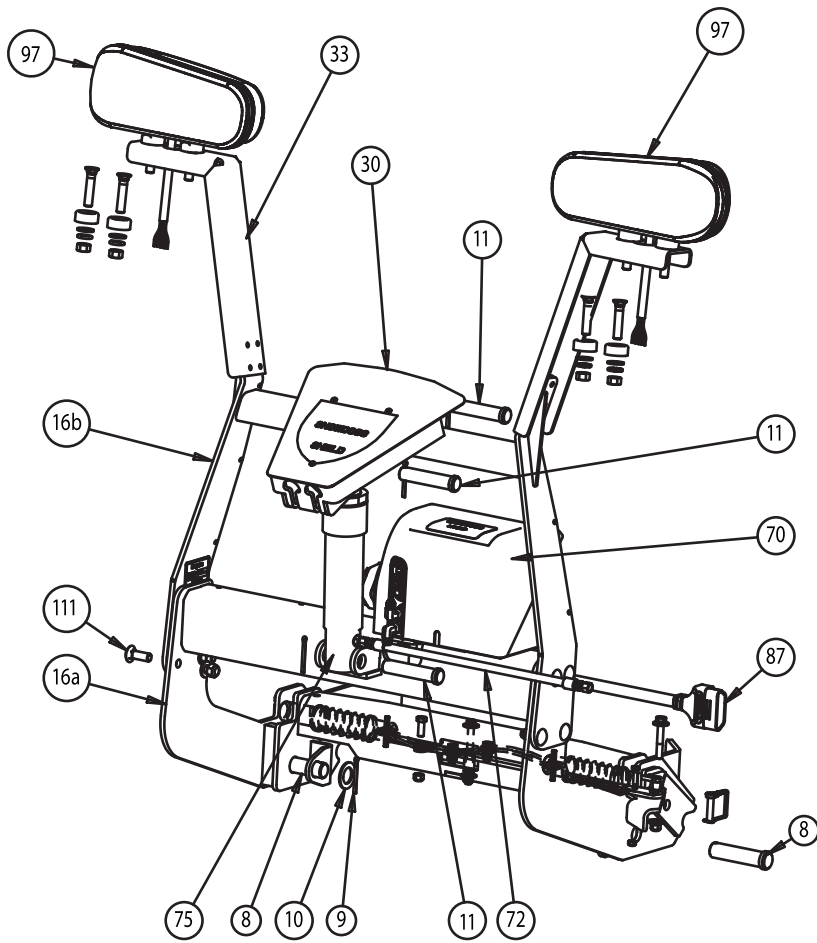

**Linkage Detail Diagram**

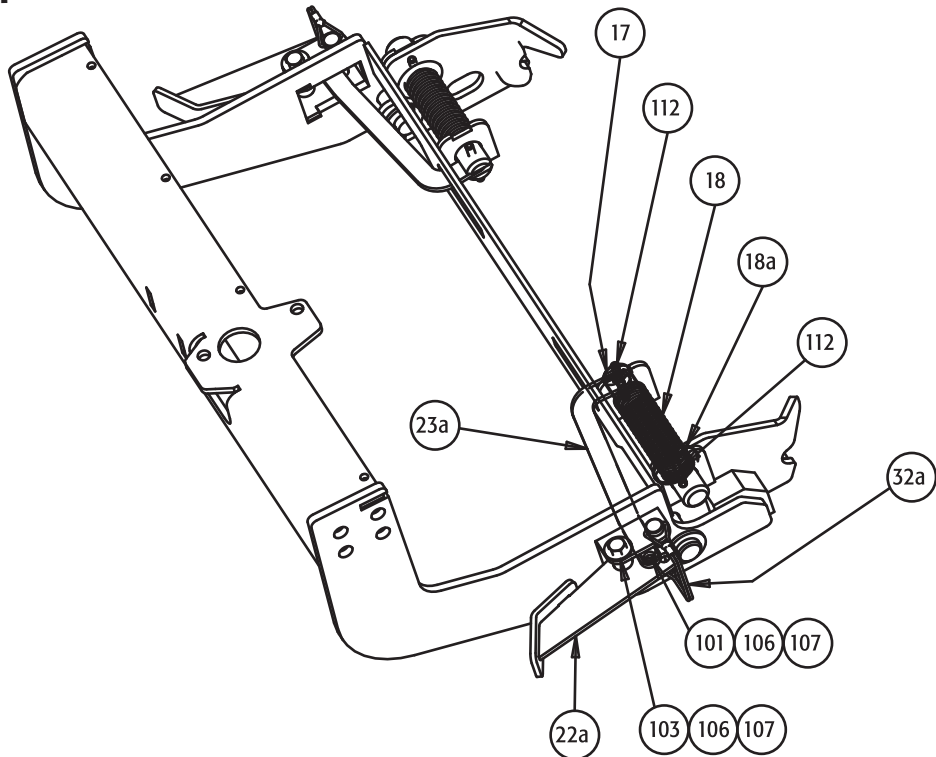

# Moldboard Diagram

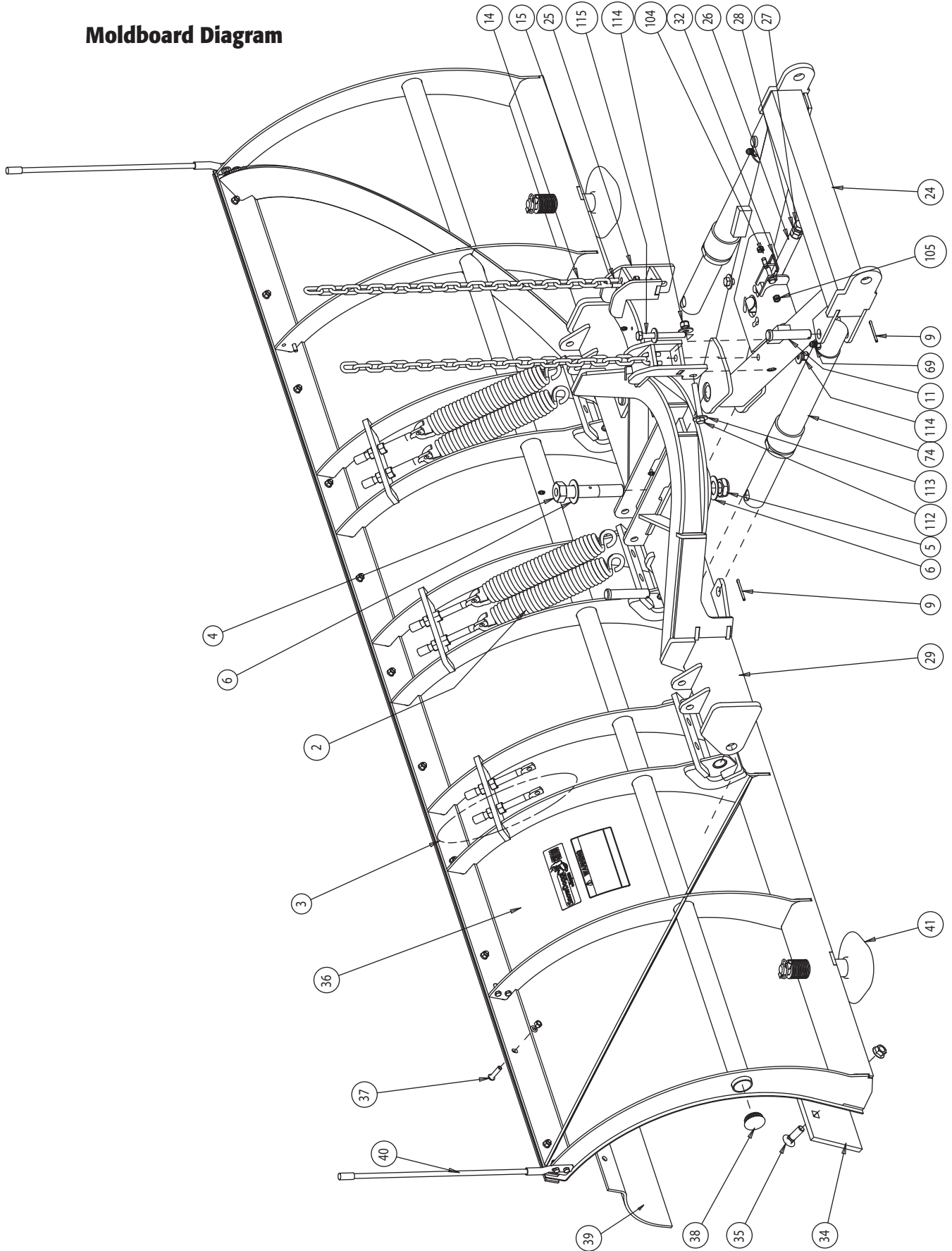

**Figure D - Hydraulic Power Unit Diagram**

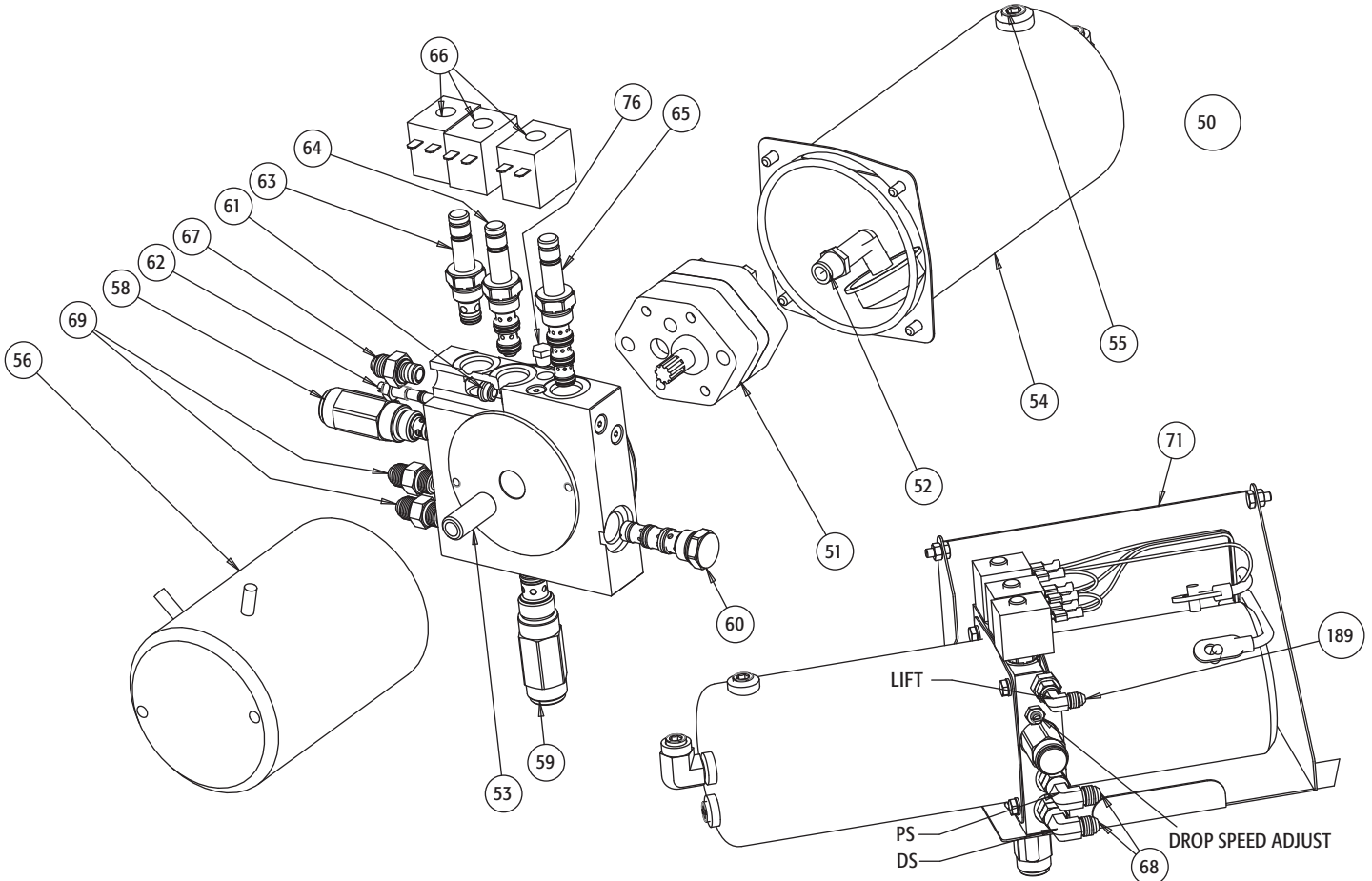

**Hydraulic Power Unit Wiring**

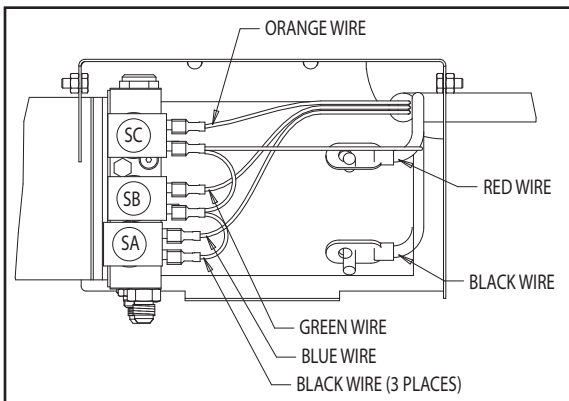

**Harness Diagram**

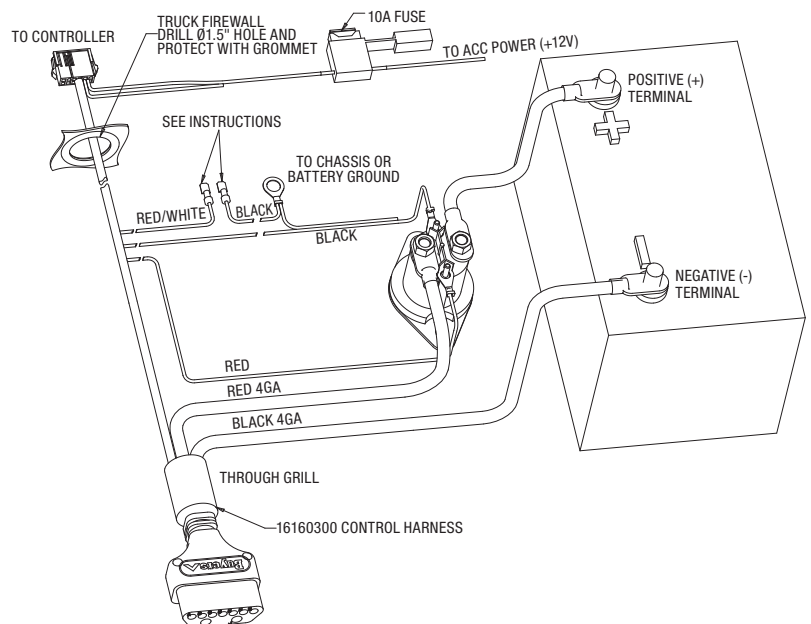



## Parts List

ITEM	PART NO.	QTY	DESCRIPTION
<b>FIGURE A - LIFT FRAME DIAGRAM</b>			
8	16102100	2	Clevis Pin, 1"x4"
9	16102102		Cotter Pin, 3/16"x2"
10	16102104	2	Washer, 1"
11	16102122	3	Clevis Pin Kit, 7/8" x 4"
16a	16110100	1	Lower Lift Frame, Assembled w/ Linkages
16a	16111612	1	Lift Frame, Lower Weldment
16b	16111620	1	Lift Frame, Upper Weldment
30	16111400	1	Chain Lift Arm (assembled)
30	16111402	1	Chain Lift Cover, w/screws
30	16111406	1	Chain Lift Fastener Kit
32	16111120	1	Snapper Pin, 1-5/8in
32a	16111124	2	Snapper Pin, 2-1/2in
33	16111510	2	Bracket, Light
67a	16151325	1	Fitting, Cyl Lift Port
72	16153100	1	Hose, Lift (1/4"x18")
75	16154200	1	Cylinder, Lift (2"x6")
75	16154202	1	Packing Kit, 2" w/Wiper Seal
75	16154204	1	Gland Nut, 2", w/Wiper Seal
87	16160402	1	Spring Cage (Kit of 2), Power terminals
87	16160512	1	Cap, 16160200/16160400
97	16160800	1	Light Kit, Pair, LED
97	16160810	1	Light, Plow, DS, LED
97	16160820	1	Light, Plow, PS, LED
97	16160700A	1	Light, Plow, Pair, Halogen
97	16160710A	1	Light, Plow, DS, Halogen
97	16160712A	1	Light Housing Only, DS, Halogen
97	16160720A	1	Light, Plow, PS, Halogen
97	16160722A	1	Light Housing Only, PS Halogen
97	16160730B	2	Hardware Kit, Light Mounting (1 set), Halogen
97	16160732	2	Seal, Light Lens to Housing, Halogen
97	16160734	2	Harness, Light Internal, Halogen
97	16160740	2	Bulb, H1 High Beam
97	16160742A	2	Bulb, H7 Low Beam
97	16160744	2	Bulb, Park/Turn, Amber
110	16111512	1	Light Bracket Fastener Kit (8 Screws/Washers/Nuts)
111	16101014	1	Lift Frame Upper/Lower Fastener Kit
<b>FIGURE B - LINKAGE DETAIL DIAGRAM</b>			
17	16111102	2	Pin, Mount Locking
18	16111104	2	Spring, Mount Locking Pin
18a	16111116	2	Washer, Flat
22a	16111117	2	Foot Pedal, Dual
23a	16111115	2	Linkage, Dual Pedal
32a	16111124	2	Snapper Pin, 2-1/2in
101	16101001	2	Screw, Cap, 3/8-16 x 1.00 SST
103	16101003	2	Screw, Cap, 3/8-16 x 3.00 ZN
106	16101006	4	Nut, Nylock 3/8-16 SST
107	16101007	6	Washer, Flat 3/8 SST
112	16111118	4	Roll Pin, 1/4x2.00
<b>FIGURE C - A-FRAME &amp; MOLDBOARD DIAGRAMS</b>			
1	16101130	1	Pin, Trip, CM (x3)
2	16101200	6	Spring, Trip
3	16101230	3	Spring Mount Eye Bolt Kit (set of 6)
4	16101120	1	Bolt, Pivot w/grease fitting, HD/EX/TE/XP
4	16101515	1	Grease Fitting, Press
4	16101516	1	Grease Fitting, 1/4-28 Threaded
5	16101122	1	Nut, Pivot/Angle Stop Bolt
6	16101124	2	Washer, Pivot/Angle Stop Bolt
9	16102102		Cotter Pin, 3/16"x2"
11	16102122	4	Clevis Pin Kit, 7/8" x 4"
14	16103000	2	Chain, Lift
15	16103020	2	U-Bolt Kit, Lift Chain w/nuts

ITEM	PART NO.	QTY	DESCRIPTION
24	16101515	1	Grease Fitting, Press
24	16114200	1	A-Frame, CM
25	16114220	1	Sector Retainer
26	16111210	1	Prop Stand Assembly (with lift bolt/nut)
27	16111212	1	Bolt, Prop Stand
28	16111214	1	Nut, Jam 5/8-11
29	16114300	1	Sector, CM
31	16111310	1	Jack, A-frame
31	16111312	1	Cap for Jack
32	16111120		Snapper Pin, 1-5/8in
34	16120662	1	Cutting Edge, 120"x5/8"
35	16120114	1	Cutting Edge Fastener Kit (set of 10)
36	16121820	1	Skin, CM100, SST
37	16120110	1	Skin Fastener Kit (set of 10)
38	16120120	2	Cap, Crosstube
39	16120164	1	Deflector, Rubber, 120"
40	16122120	1	Blade Guide Assembly (pr)
41	16121100	2	Shoe Assembly
41	16121120	16	Shoe, Washer (1/8")
41	16121140	2	Shoe, Linch Pin
42	16120264	1	Clamp Strip, 120"
69	16151324	2	Fitting, Mfd/Cyl Angle Straight
73	16153110	2	Hose, Angle (3/8"x36")
74	16154140	2	Cylinder, Angle (2"x12")
104	16101004	1	Screw, Cap, 3/8-16 x 2.00 ZN
105	16101005	1	Nut, Nylock 3/8-16
112	16101010	2	Screw, Cap, 1/2-13x3.50 ZN
113	16101013	2	Washer, Flat 1/2, ZN
114	16101015	4	Nut, Nylock, 1/2-13 ZN
115	16101011	2	Screw, Cap, 1/2-13x4.50 ZN
<b>FIGURE D - HYDRAULIC POWER UNIT DIAGRAM</b>			
50	16151000	1	Hydraulic Power Unit, Straight Blade
51	16151100	1	Pump, Gear
51	16159116	1	Seal, Shaft
52	16151102	1	Inlet Strainer
53	16151106	1	Spline Coupler
54	16151110	1	Reservoir Kit (Res/Bolts/Seal/Cap)
54	16159114	1	O-ring, Reservoir
55	16151112	2	Plug, Reservoir, 3/8" NPT
56	16151200	1	Motor, 1.6kW
58	16151302	1	Valve, Main Relief
59	16151304	1	Valve, Angle Cross Over Relief
60	16151306	1	Valve, Angle Lock
61	16151308	1	Valve, Lift Check
61	16900010		Tool, Lift Check Valve Removal
62	16151310	1	Valve, Lowering Speed
63	16151312	1	Valve, SA Solenoid
64	16151314	1	Valve, SB Solenoid
65	16151316	1	Valve, 4-WAY/2-POS Solenoid
66	16151318	3	Coil, SA/SB/SC Valves
67	16151320	1	Fitting, Mfd Lift Port
68	16151322	2	Fitting, Mfd Angle/Lift Elbow
69	16151324	2	Fitting, Mfd/Cyl Angle Straight
71	16152110	1	Tray, HPU, SST
71	16152128	1	Grommet, HPU Tray
76	16151326	1	Breather, Vent
189	16151321	1	Fitting, Manifold Lift Port 90 Deg Swivel

ITEM	PART NO.	QTY	DESCRIPTION
<b>FIGURE E - HARNESS DIAGRAM</b>			
80	16160100	1	Harness, Truck Relay
80	16160110	1	Repair Connector, 16160100 Grill Connector
80	16160112	2	Repair Connector, 16160100 Adapter Connector
80	16160116	1	Plate, Mounting, Relay Harness
80	16160510	1	Cap, 16160100/16160300
83	16160114	6	Relay, Light, Individual
84	16160200	1	Harness, Plow Light
84	16160512	1	Cap, 16160200/16160400
85	16160300	1	Harness, Truck Control
85	16160310	1	Repair Connector, 16160300 Grill Connector
85	16160510	1	Cap, 16160100/16160300
88	16160410	1	Relay, Motor
89	16160500	1	Cable, Battery
98	16160600	1	Controller, Straight Blade
98	16160610		Harness, Controller Extension (36")
98	16160620	1	Mount Kit, SnowDogg Controller

## TROUBLESHOOTING

SYMPTOM		RESULT	FIX
<b><i>Pump motor not running when UP, LEFT or RIGHT pressed</i></b>			
	Check voltage at MOTOR terminals with UP, LEFT, or RIGHT buttons pressed	If voltage present - MOTOR is bad	Replace MOTOR
	Check cable continuity between MOTOR RELAY and MOTOR	If no continuity, check cable, connections, and replace if necessary	Replace/repair cable or connections
	Check control signal to MOTOR RELAY (small wires to motor relay) with UP, LEFT, or RIGHT buttons pressed	If voltage present and no click is heard when buttons are pressed, MOTOR RELAY is bad	Replace MOTOR RELAY
	Check ground continuity between between control ground at MOTOR RELAY and battery ground	If no continuity, check cable, connections, and replace if necessary	Replace/repair cable or connections
<b><i>Plow won't move at all, moves "jerkily", very slowly, or chatters</i></b>			
	Check fluid level in reservoir	Fluid should be visible from fill cap - reservoir should be ~3/4 full	Add fluid
	Air in fluid	Bleed air from system	Slightly loosen fittings to angle cylinders and angle the plow. Tighten fittings while fluid is escaping. Do this over an absorbent mat, or hold a rag over fitting to absorb excess fluid.
<b><i>Plow won't drop</i></b>			
	Check voltage at SA VALVE coil	If no voltage present, check cable and connections	Replace/repair cable or connections
			Confirm BLUE wire at SA VALVE
	Check DROP SPEED control valve	DROP SPEED valve should be several turns from fully closed	Open DROP SPEED valve
	Check SA VALVE for contamination	Poppet must move freely, and seat area must be clear of any debris	Remove SA VALVE and check free movement of poppet, clean any chips/debris from poppet seat
			Replace SA VALVE
	Check LIFT LOCK valve for contamination	Poppet must move freely, and seat area must be clear of any debris	Remove LIFT LOCK valve and check free movement of poppet, clean any chips/debris from poppet seat
			Replace LIFT LOCK valve
<b><i>Plow won't lift or won't angle in either direction</i></b>			
	Check voltage at SB VALVE coil	If no voltage present, check cable and connections	Replace/repair cable or connections
			Confirm GREEN wire at SB VALVE
	Check SB VALVE for contamination	Spool must move freely, and seat area must be clear of any debris	Remove SB VALVE and check free movement of spool, clean any chips/debris from valve
			Replace SB VALVE

SYMPTOM		RESULT	FIX
<b><i>Plow won't angle in one direction</i></b>			
	Check voltage at SC VALVE coil	If no voltage present, check cable and connections	Replace/repair cable or connections
			Confirm ORANGE wire at SC VALVE
	Check SC VALVE for contamination	Spool must move freely, and seat area must be clear of any debris	Remove SC VALVE and check free movement of spool, clean any chips/debris from valve
			Replace SC VALVE
<b><i>Plow drifts while plowing snow</i></b>			
	Air in Fluid	Bleed air from system	Slightly loosen fittings to angle cylinders and angle the plow. Tighten fittings while fluid is escaping. Do this over an absorbent mat, or hold a rag over fitting to absorb excess fluid.
	Check ANGLE LOCK valve for contamination	Poppet must move freely, and seat and piston area must be clear of any debris	Remove ANGLE LOCK valve and clean
			Replace ANGLE LOCK valve
	Check CROSS RELIEF valve for contamination	Poppet must move freely, and seat must be clear of any debris	Remove CROSS RELIEF valve and clean
			Replace CROSS RELIEF valve
<b><i>Oil is leaking from cylinders</i></b>			
		Packing is loose	Tighten until leak stops
		Rods are pitted	Polish rods with fine steel wool
			Replace cylinder
<b><i>Oil sprays out of vent port in power unit</i></b>			
	Air in Fluid	Bleed air from system	Slightly loosen fittings to angle cylinders and angle the plow. Tighten fittings while fluid is escaping. Do this over an absorbent mat, or hold a rag over fitting to absorb excess fluid.
	Check fluid level	Fluid should be visible from fill cap - reservoir should be 3/4 full	Remove fluid if necessary - in most cases the problem will subside as entrapped air dissipates.

## **PLOWING TIPS**

- Know the area you are plowing. Be aware of all hidden obstacles (pipes, drains, berms, etc.)
- Plow with the storm, do not let snow accumulate
- Always lower the plow blade when parking to minimize the risk of the plow dropping and to reduce the load on the truck suspension.
- When transporting the plow – monitor coolant temperature. If the truck is running hot, adjust the plow position to allow additional airflow to the radiator.
- Plowing at high speeds increases the potential for damage to your plow AND your truck