

HD/EX MOUNT KIT

16061190

FORD F250/F350 '92-'97



SnowDogg® Snowplow

TRUCK MOUNT INSTALLATION MANUAL

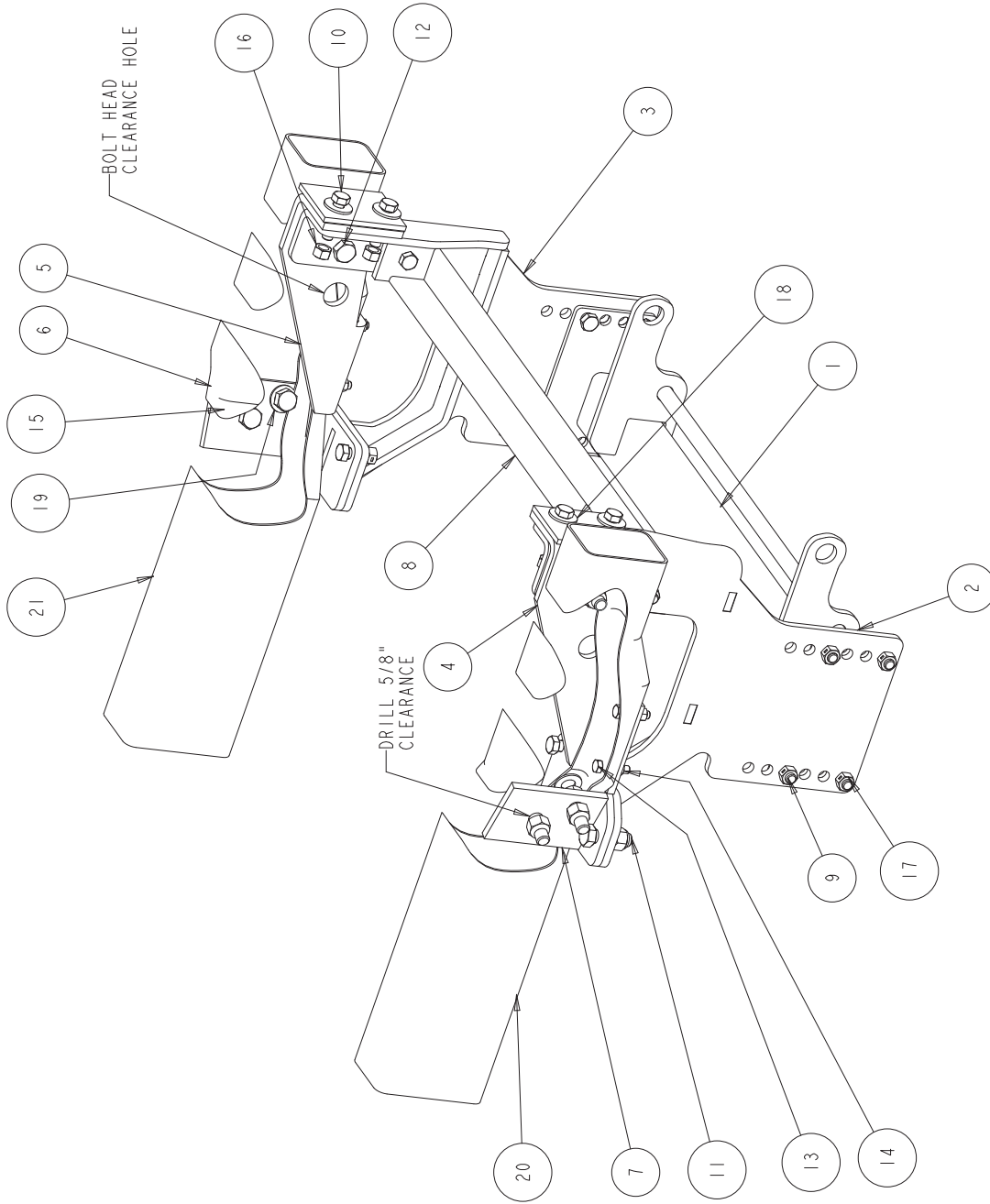

Parts List

ITEM	PART NO.	QTY.	DESCRIPTION
1	16061198	1	Pushbar, Ford F250 HD Mount
2	16061191	1	Side Plate, Weldment PS
3	16061192	1	Side Plate, Weldment DS
4	3015673	1	Stiffeners, Frame PS
5	3015674	1	Stiffeners, Frame DS
6	16061193	1	Bracket, Upper DS Weldment
7	16061194	1	Bracket, Upper PS Weldment
8	16061197	1	Bar, Stiffener
9	-	12	Screw, Hex HD - 1/2-13 x 1-1/2 Gr. 8 ZN
10	-	4	Screw, Hex Cap 1/2-13 x 2" Gr. 5 ZN
11	-	6	Screw, Hex Cap 5/8-11 x 2" Gr. 5 ZN

ITEM	PART NO.	QTY.	DESCRIPTION
12	-	2	Cap Screw, 5/8-18 x 2 1/2 Gr. 8 Plain
13	-	4	Screw, HX HD Cap 3/8-16 x 1 1/2 Gr. 5 ZN
14	-	4	Nut, 3/8-16 Hex ZP
15	-	8	Nut, Hex Nylock 5/8-11 SST
16	-	4	Nut, 1/2-13 Hex Gr. 8 ZP
17	-	12	Locknut, Hex 1/2-13, Zinc Gr 8
18	-	4	Washer, Flat, .500 x 1.38 x .14, ZN
19	-	4	Washer, 5/8 SAE Flat ZN
20	-	1	PS Frame
21	-	1	DS Frame

INSTRUCTIONS

1. Remove the front bumper, bumper fasteners, and skid plate. Set aside for later reinstallation.
2. Remove the tow hooks (if your vehicle option is equipped with them). In some models, it is necessary to remove the swaybar.
3. Hold the PS Side Plate Bracket (2) up against the passenger side frame rail, aligning with the existing holes where the bumper is fastened. Secure the Bracket [temporarily] using two 1/2-13 bolts (10), and two locknuts (16). Notice, you have to sandwich the PS, stiffeners (4) in between the side plates and the truck-frame.

Fig. 1

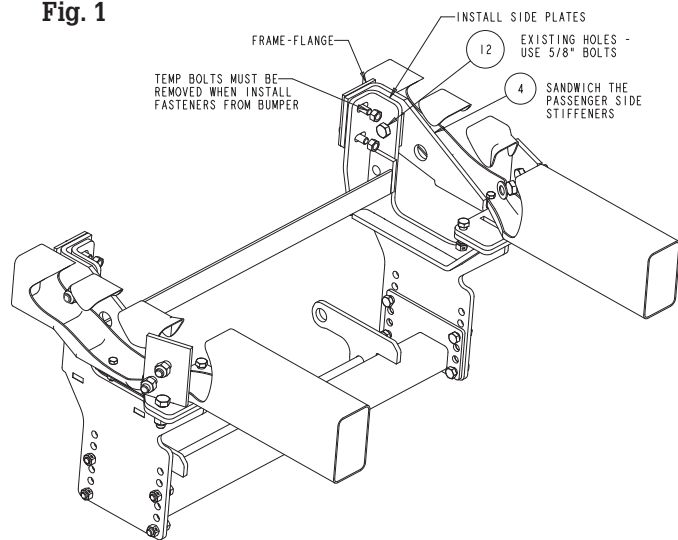

4. Install the additional rear Support Bracket (7) onto the rear of the frame. Secure the Bracket through an existing hole through the frame with one 5/8-11 x 2" bolt (11) and a nut (15). Drill the upper holes as needed and secure it with

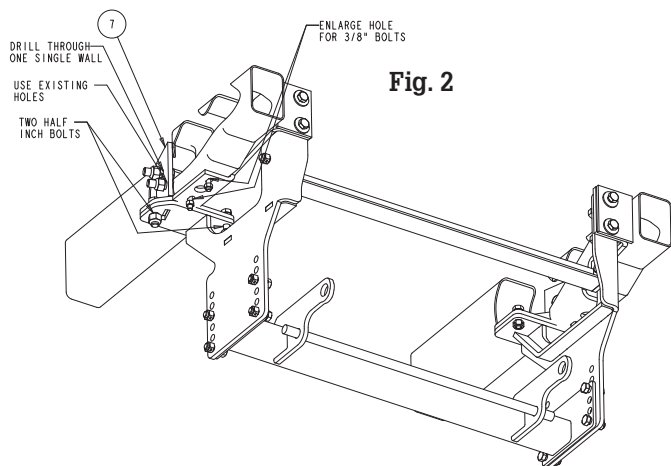

another 5/8-11x 2" bolt and nut.

5. Secure the Side Plates (2) to the Rear Bracket (7) with two 1/2" bolts and nuts (11 & 17).
6. To the bottom of the frame looking skyway, secure the two 3/8" bolts and nuts (13, 14). You may have to enlarge the size of the existing holes.

Fig. 3

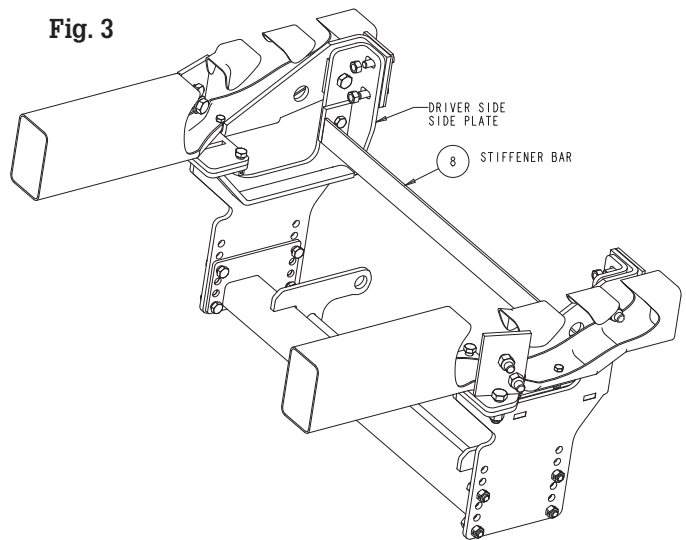

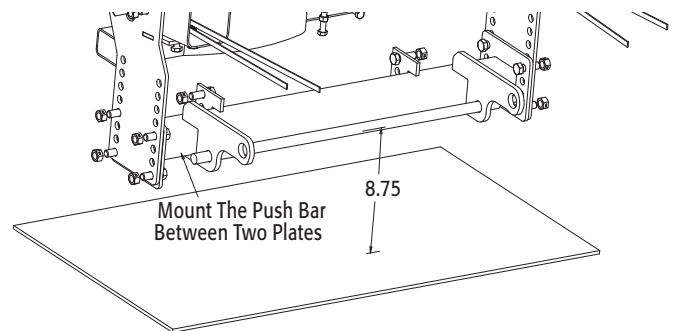

7. Repeat the step 3-6 for the Driver Side.
8. Mount the Stiffener Bar (8) across the two side plates. Secure it with two 1/2" bolts and nuts (9 & 17).
9. Mount the Pushbar (1) in place between the two side plates using eight 1/2-13x1-1/2 bolts (9), eight locknuts (17). The centerline of the pushbar crosspin should be approximately 8.75" from the ground. Improper mounting

Fig. 4



height will result in uneven cutting edge wear.

10. Torque all fasteners as shown in the chart. Check and re-torque all fasteners after 5 hours of usage to ensure safe plow operation.
11. It may be helpful to route the plow and light control harnesses at this point, prior to bumper reinstallation.
12. Reinstall the bumper/air dam assembly and skid plate. The bumper/air dam and skid plate may need to be altered or omitted for reinstallation.

Recommended Fastener Torque Chart (ft.-lb.)			
Size	 SAE Grade 2	 SAE Grade 5	 SAE Grade 8
1/4-20	6	9	13
5/16-18	11	18	28
3/8-16	19	31	46
3/8-24	24	46	68
7/16-14	30	50	75
1/2-13	45	75	115
9/16-12	66	110	165
5/8-11	93	150	225
3/4-10	150	250	370
7/8-9	150	378	591
1-8	220	583	893
Metric Grade 8.8 (ft.-lb.)			
Size	Torque	Size	Torque
M6	7	M12	60
M8	17	M14	95
M10	35	M16	155
These torque values apply to fasteners except those noted in the instruction.			

WARNING

- DO NOT under any circumstances disable, remove or relocate any sensors or components related to the operation of the air bags.
- Always follow the vehicle manufacturers' recommendations relating to snowplow installation.
- To comply with Federal Regulations and to assure a safe vehicle, the Front Gross Axle Weight Rating (FGAWR), Rear Gross Axle Weight Rating (RGAWR), and the Gross Vehicle Weight Rating (GAWR) must not be exceeded at any time.
- Due to the variety of equipment that can be installed on this vehicle, it is necessary to verify that the Front Gross Axle Weight Rating (FGAWR), Rear Gross Axle Weight Rating (RGAWR), and the Gross Vehicle Weight Rating (GAWR) are not exceeded at any time. This may require weighing the vehicle and adding ballast as necessary. It may also limit payload capacity of the vehicle. It is the operator's responsibility to verify that these ratings are not exceeded.

CAUTION

- Read all instructions prior to assembly
- It is critical that all fasteners be properly torqued for safe plow operation – see chart above.
- Fasteners should be retorqued after 5-8 hours of plow use

FULL ONE-YEAR WARRANTY

Manufacturer will repair, or at manufacturer's discretion will replace any part of this snowplow which proves to be defective in workmanship or material under normal use for a period of one year from the date of delivery to the original purchaser. Any cost incurred in returning the product to the supplier is the responsibility of the consumer.

EXCLUSIONS

Manufacturer shall not be liable for special, incidental, or consequential damages, or for damages resulting from lack of necessary maintenance, from misuse, abuse, acts of God, or alteration of the product. Some states do not allow the exclusion or limitation of incidental or consequential damages, so the above limitation or exclusion may not apply to you.