

MD MOUNT KIT 16062105

YUKON/SUBURBAN/AVALANCHE/TAHOE 1500 '03-'07
GM1500 '03-'07
GM CLASSIC '07



SnowDogg™ Snowplow

TRUCK MOUNT INSTALLATION MANUAL

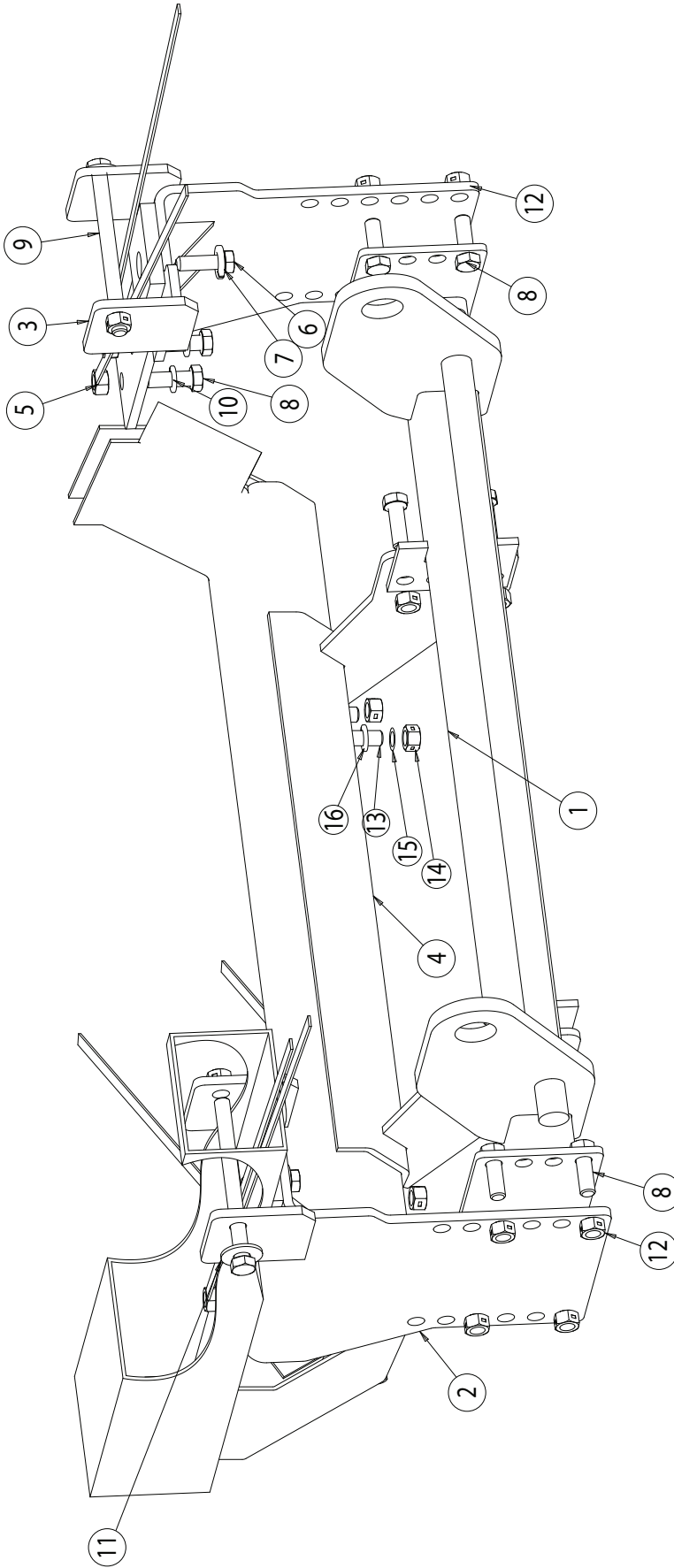

Parts List

| ITEM | PART NO. | QTY. | DESCRIPTION |
|------|--------------|------|--|
| 1 | 16062108 | 1 | Pushbar |
| 2 | 16062106 | 1 | Mount, PS GM 1500 99+ |
| 3 | 16062104 | 1 | Mount, DS GM 1500 99+ |
| 4 | 16062107 | 1 | Bracket, Cen-Support GM1500 |
| 5 | 3011523 | 4 | Nut, Hex, 1/2-13 w/Handle, Gr. 8 |
| 6 | 3009978 | 2 | Screw, M12-1.75x40 MM HH Class 10.9, ZN |
| 7 | 3009979 | 2 | Washer, Lock M12 HEL Spring Yellow, ZN |
| 8 | 3006202 | 16 | Screw, Hex HD, 1/2-13 x 1-1/2, ZN Gr. 8 |
| 9 | 3011524 | 2 | Screw, Hex HD, 1/2-13 x 6, Gr. 8 ZN |
| 10 | FWL050088011 | 4 | Washer, Heavy Helical Spring Lock, 1/2", BLK Oxide |
| 11 | FWF050138014 | 2 | Washer, Flat, .500 x 1.38 x .14, ZN |
| 12 | 3002397 | 14 | Locknut, Hex 1/2-13, ZN Gr. 8 |
| 13 | 16801004 | 4 | Screw, Hex HD, 1/2-13 x 1-1/2 Gr. 5 w/HDL |
| 14 | 3006201 | 4 | Nut, 1/2-13 Hex GR 8 ZN |
| 15 | FWL050088013 | 8 | Washer, Lock 1/2" Split ZN |
| 16 | FWF050106010 | 4 | Washer, Flat 1/2" ZN |

INSTRUCTIONS

1. Remove the existing tow hook bolts – these will not be reused. If necessary, remove the bumper and bumper fasteners.

2. Hold the **PS SIDE MOUNT PLATE (2)** against the frame, aligning with the existing tow hook holes.

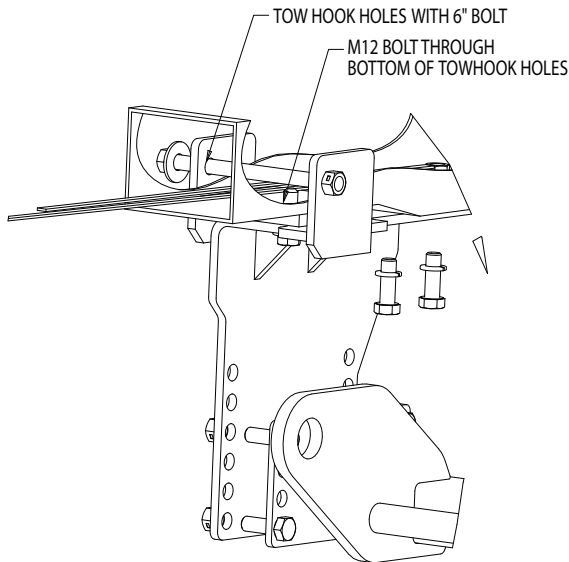

3. Keep the tow hook in place, loosely install one **½"-13x6" HEX HEAD BOLT (9)** horizontally through the frame and tow hook. Loosely install an **M12X40 BOLT (6)** and **M12 LOCKWASHER (7)** through the bottom of the frame and into the existing tow hook. These are for alignment only – do not tighten.

4. It may be helpful to clamp the **PS SIDE MOUNT PLATE** in position if possible.

5. Using the rear holes in the **PS SIDE MOUNT PLATE (2)** as a template, drill two $\varnothing.531$ " holes through the bottom of frame.

6. Remove the tow hook previously installed (*optional*).

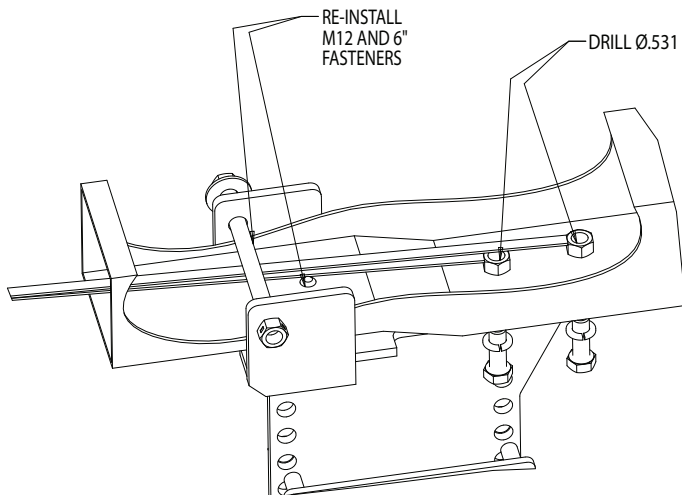

7. Position the **PS SIDE MOUNT PLATE (2)** against the frame and secure using **TWO ½"-13 HEX NUTS W/HANDLES (5)** on the inside of the frame, **TWO ½"-13X1-1/2" BOLTS (8)** and **TWO ½" LOCK WASHERS (10)** from the bottom.

8. Reinstall front fasteners, **ONE ½"-13X6" HEX HEAD BOLT (9)** with **ONE ½"-13 FLAT WASHER (11)** and **ONE ½"-13 LOCK NUT (12)**. Also reinstall **ONE M12X40 HEX HEAD BOLT (6)** and **ONE M12 LOCKWASHER (7)**.

9. Repeat steps 2-8 for the **DS SIDE MOUNT PLATE**.

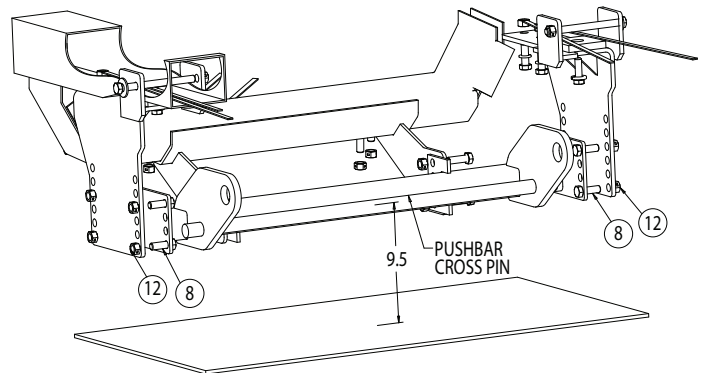

10. Mount the **PUSHBAR (1)** in place between the two side plates using **EIGHT ½"-13X1-1/2" HEX HEAD BOLTS (8)** and **EIGHT ½"-13 LOCK NUTS (12)**. The centerline of the **PUSHBAR CROSSPIN** should be approximately 9.5" from the ground. The air dam of the vehicle may need to be altered to accommodate this height. Improper mounting height will result in uneven cutting edge wear.

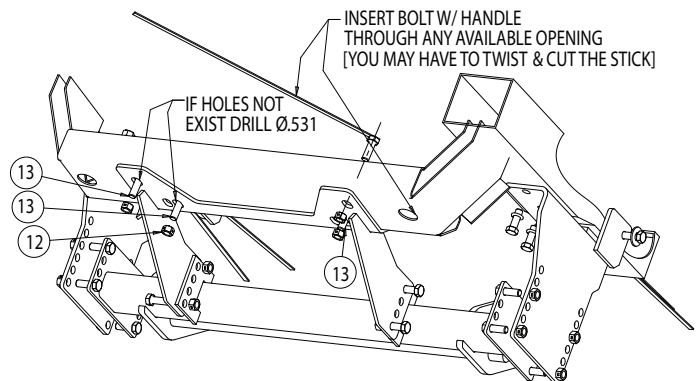

11. Install the **CEN-SUPPORT BRACKET (4)** to the push bar using four ½-13 bolts (8) and four locknuts (12). By holding up the part to the cross-member beam, drill out four 9/16" holes (if not already exist). Use the four ½-13 **BOLT WITH HANDLES (13)** and four locknuts to secure it onto the beam. You may have to loosen all fasteners in order to attach them.



12. Torque all fasteners as shown in the chart. Check and re-torque all fasteners after 5 hours of usage to ensure safe plow operation. Ensure all coolant lines and wires are clear of moving or hot components and tie up as necessary.

| Recommended Fastener Torque Chart (ft.-lb.) | | | |
|--|---|---|--|
| Size |  SAE Grade 2 |  SAE Grade 5 |  SAE Grade 8 |
| 1/4-20 | 6 | 9 | 13 |
| 5/16-18 | 11 | 18 | 28 |
| 3/8-16 | 19 | 31 | 46 |
| 3/8-24 | 24 | 46 | 68 |
| 7/16-14 | 30 | 50 | 75 |
| 1/2-13 | 45 | 75 | 115 |
| 9/16-12 | 66 | 110 | 165 |
| 5/8-11 | 93 | 150 | 225 |
| 3/4-10 | 150 | 250 | 370 |
| 7/8-9 | 150 | 378 | 591 |
| 1-8 | 220 | 583 | 893 |

| Metric Grade 8.8 (ft.-lb.) | | | |
|-----------------------------------|--------|------|--------|
| Size | Torque | Size | Torque |
| M6 | 7 | M12 | 60 |
| M8 | 17 | M14 | 95 |
| M10 | 35 | M16 | 155 |

These torque values apply to fasteners except those noted in the instruction.

WARNING

- DO NOT under any circumstances disable, remove or relocate any sensors or components related to the operation of the air bags.
- Always follow the vehicle manufacturers' recommendations relating to snowplow installation.
- To comply with Federal Regulations and to assure a safe vehicle, the Front Gross Axle Weight Rating (FGAWR), Rear Gross Axle Weight Rating (RGAWR), and the Gross Vehicle Weight Rating (GAWR) must not be exceeded at any time.
- Due to the variety of equipment that can be installed on this vehicle, it is necessary to verify that the Front Gross Axle Weight Rating (FGAWR), Rear Gross Axle Weight Rating (RGAWR), and the Gross Vehicle Weight Rating (GAWR) are not exceeded at any time. This may require weighing the vehicle and adding ballast as necessary. It may also limit payload capacity of the vehicle. It is the operator's responsibility to verify that these ratings are not exceeded.

CAUTION

- Read all instructions prior to assembly
- It is critical that all fasteners be properly torqued for safe plow operation – see chart above.
- Fasteners should be retorqued after 5-8 hours of plow use

FULL ONE-YEAR WARRANTY

Manufacturer will repair, or at manufacturer's discretion will replace any part of this snowplow which proves to be defective in workmanship or material under normal use for a period of one year from the date of delivery to the original purchaser. Any cost incurred in returning the product to the supplier is the responsibility of the consumer.

EXCLUSIONS

Manufacturer shall not be liable for special, incidental, or consequential damages, or for damages resulting from lack of necessary maintenance, from misuse, abuse, acts of God, or alteration of the product. Some states do not allow the exclusion or limitation of incidental or consequential damages, so the above limitation or exclusion may not apply to you.