

MD MOUNT KIT

16062140A

GM 1500, 2014+



SnowDogg™ Snowplow

TRUCK MOUNT INSTALLATION MANUAL

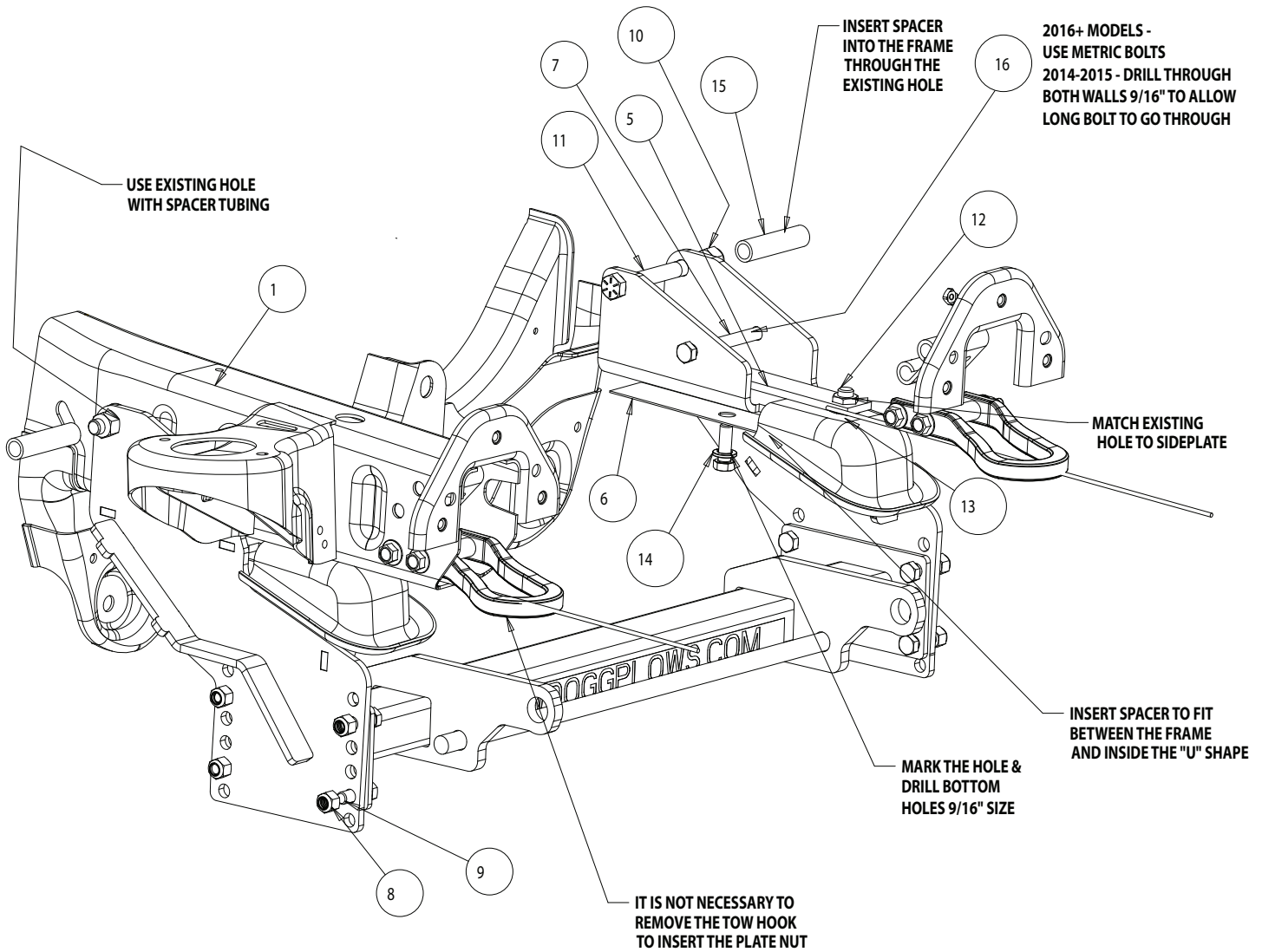

Parts List

ITEM	PART NO.	QTY.	DESCRIPTION
1	16062115_FRAME	1	2014 GM Truck Frame
2	16062147	1	Push-Bar, GM 1500 2014+ HD/EX
3	16062141	1	2014 Bracket, Side Plate Weldment DS
4	16062142	1	2014 Bracket, Side Plate Weldment PS
5	3026419	2	Nut Plate, 2014 GM
6	3026420	2	Washer, Rectangular Large
7	FCS050013550	2	Screw, HHC - 1/2-13 x 5-1/2 Gr. 5 ZN
8	3002397	10	Locknut, Hex Nylock, 1/2-13 ZN, G8
9	3006202	10	Screw, Hex JD - 1/2-13 x 1-1/2 Gr. 8 ZC
10	FNE063011069	2	Nut, Nylock 58-11, ZN
11	FCS063011550Z	2	Screw, HH Cap, 5/8-11 x 5.5 Gr. 8 ZN SPC
12	FCS063011150Z01	2	Screw, HH Cap, 5/8-11 x 1.5 Gr. 5 ZN
13	FWL063108016	2	Washer, 5/8" Regular Split Lock, ZN
14	FWL050088013	2	Washer, Lock - 1/2 Split SN
15	3026423	2	Tube, Spacer GM 2014
16	3033912	2	M14-2 x 65 MM, Screw

INSTRUCTIONS

*It is not necessary to remove the bumper or tow hooks.

1. Installing a leveling kit is recommended, to avoid cutting the bumper. (Leveling Kit Part No. 5562112)
2. Remove the plastic mud-guard at the bottom of the frame by removing the screws on the perimeter. Re-locate a small screw on the driver side that holds the thin plastic plate near the fuse box. **For 2015 & newer vehicles, a wish bone bracket must be relocated with a spacer sandwiching in between.** See Fig. 1.

FOR 2015+ MODEL, A ROUND WISH BONE BRACKET MUST BE TEMPORARILY REMOVED AND RE-INSTALLED LIKE A SANDWICH

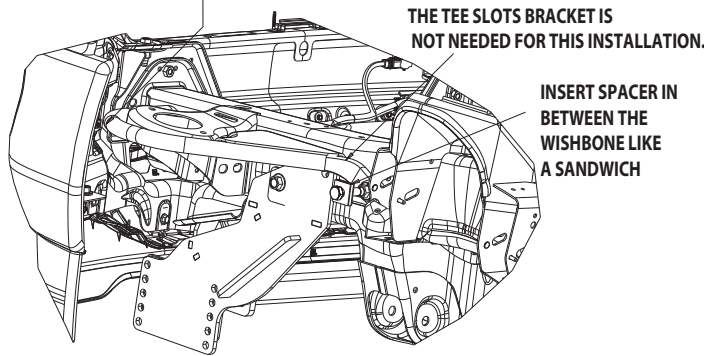

Fig. 1

3. Pry out the tow hook foam in the front of the tow hooks in order to access the inside of the frame. Keep foam for later reinstallation.
4. Insert the **Spacer Tubings** through the 1" hole.
5. Insert the **Double Nut Plate** into the frame through the foamed crevices that you just opened. Align the 5/8" nut onto the bottom hole of the frame while holding onto the stick firmly.
6. Hold the **PS Plate** up against the frame to align the 5/8" nut hole at the bottom of the **Catcher Cup**. Attach the spacer washer to the bottom of the side plate and align it to the existing hole. Secure the **Side Plate** into position with the 5/8" bolt and lock washer provided.
7. Mark and drill the bottom hole with 9/16" drill bit. Be careful not to drill through the nut plate inside the frame. It is necessary to remove the double-nut plate prior to drilling. Mark and drill the upper hole with the 9/16" drill bit as well. Reinstall the side plate and secure them with proper fasteners provided. See Fig. 2.

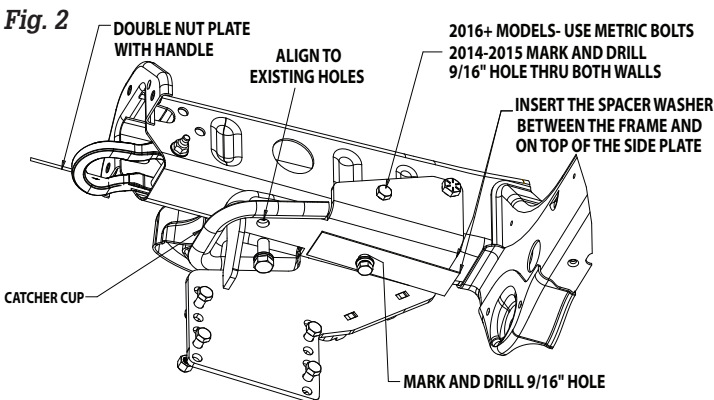

Fig. 2

8. Repeat step number 6-9 for the drivers side. See Fig. 3.

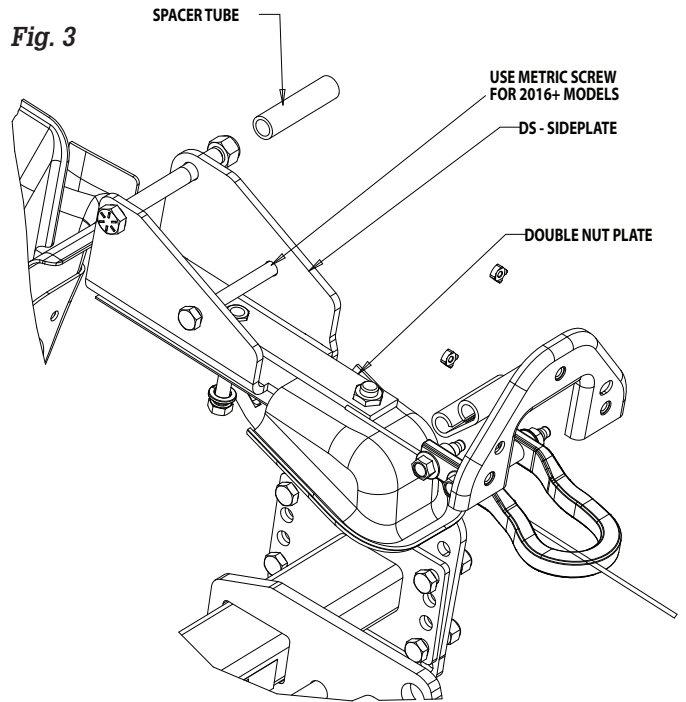
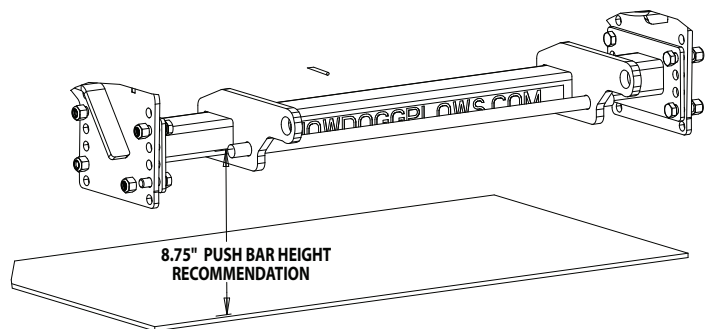





Fig. 3

9. Assemble the **Push-Bar** between the two **Side Plates** using eight 1-1/2" bolts provided. Adjust the **Push-Bar** up and down. The center line of the **Push-Bar Cross Pin** should be approximately 8-3/4" from the level ground. It is necessary to notch the plastic damper to raise the **Push-Bar** up to desired height.



10. Torque all fasteners as shown in the chart. Check and re-torque all fasteners after 5 hours of usage to ensure safe plow operation. Ensure all coolant lines and wires are clear from moving or hot components. Reinstall mud-guard and tow hook foam, removed earlier. Modification is necessary for reinstallation of the mud-guard.

Recommended Fastener Torque Chart (ft.-lb.)			
Size	 SAE Grade 2	 SAE Grade 5	 SAE Grade 8
1/4-20	6	9	13
5/16-18	11	18	28
3/8-16	19	31	46
3/8-24	24	46	68
7/16-14	30	50	75
1/2-13	45	75	115
9/16-12	66	110	165
5/8-11	93	150	225
3/4-10	150	250	370
7/8-9	150	378	591
1-8	220	583	893
Metric Grade 8.8 (ft.-lb.)			
Size	Torque	Size	Torque
M6	7	M12	60
M8	17	M14	95
M10	35	M16	155
These torque values apply to fasteners except those noted in the instruction.			

WARNING

- DO NOT under any circumstances disable, remove or relocate any sensors or components related to the operation of the air bags.
- Always follow the vehicle manufacturers' recommendations relating to snowplow installation.
- To comply with Federal Regulations and to assure a safe vehicle, the Front Gross Axle Weight Rating (FGAWR), Rear Gross Axle Weight Rating (RGAWR), and the Gross Vehicle Weight Rating (GAWR) must not be exceeded at any time.
- Due to the variety of equipment that can be installed on this vehicle, it is necessary to verify that the Front Gross Axle Weight Rating (FGAWR), Rear Gross Axle Weight Rating (RGAWR), and the Gross Vehicle Weight Rating (GAWR) are not exceeded at any time. This may require weighing the vehicle and adding ballast as necessary. It may also limit payload capacity of the vehicle. It is the operator's responsibility to verify that these ratings are not exceeded.

CAUTION

- Read all instructions prior to assembly
- It is critical that all fasteners be properly torqued for safe plow operation – see chart above.
- Fasteners should be retorqued after 5-8 hours of plow use

FULL ONE-YEAR WARRANTY

Manufacturer will repair, or at manufacturer's discretion will replace any part of this snowplow which proves to be defective in workmanship or material under normal use for a period of one year from the date of delivery to the original purchaser. Any cost incurred in returning the product to the supplier is the responsibility of the consumer.

EXCLUSIONS

Manufacturer shall not be liable for special, incidental, or consequential damages, or for damages resulting from lack of necessary maintenance, from misuse, abuse, acts of God, or alteration of the product. Some states do not allow the exclusion or limitation of incidental or consequential damages, so the above limitation or exclusion may not apply to you.