

HD/EX MOUNT KIT

16062180

GM 1500, '19+



SnowDogg® Snowplow

TRUCK MOUNT INSTALLATION MANUAL

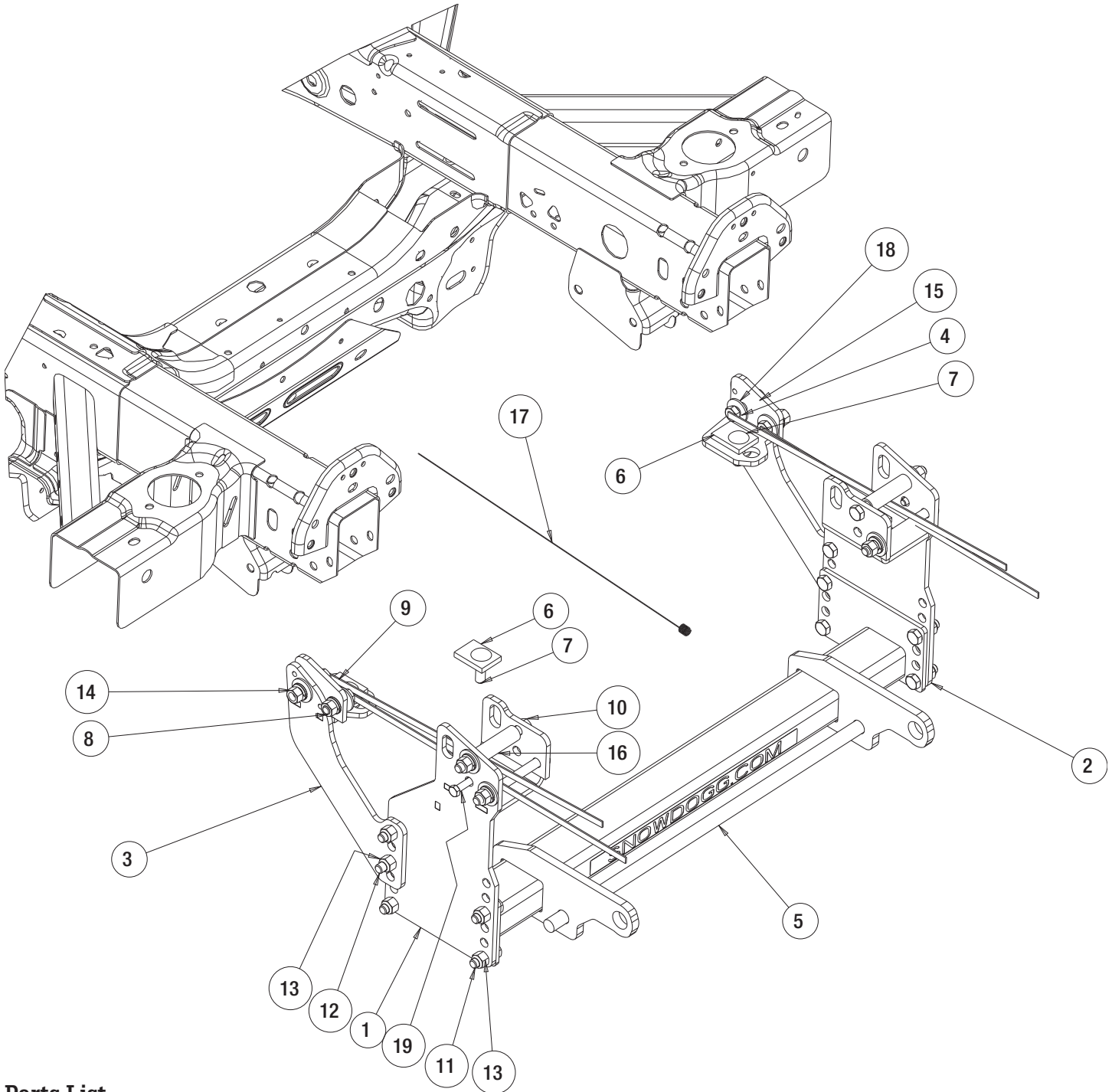

Parts List

ITEM	PART NO.	QTY.	DESCRIPTION
1	16062126	1	SIDEPLATE, PS, GM 1500 19+
2	16062127	1	SIDEPLATE, DS, GM 1500 19+
3	16062128	1	REAR BRACE, PS, 19 GM
4	16062129	1	REAR BRACE, DS, 19 GM
5	16061153A	1	PUSHBAR, FORD F250-F550 HD/EX MOUNT
6	3014859	4	RECTANGLE, SQUARE HOLE 2IN L
7	3029357	4	BOLT, CARRIAGE 1/2-13 X 1.75 GR8 ZN
8	16801004	2	SCREW, HEX HD, 1/2-13x1-1/2 GR 5 W/HDL
9	16801005	2	SCREW, HEX HD, 1/2-13x2.0 GR 5 W/HDL
10	FCS050013500	4	SCREW, HHC-1/2-13 X 5 GR 5 ZN

ITEM	PART NO.	QTY.	DESCRIPTION
11	3006202	8	SCREW, HEX HD - 1/2-13 X 1-1/2 GR 8 ZC
12	3001127	2	SCREW, HH CAP 1/2-13 X 2 GR8 ZN
13	3002397	10	LOCKNUT, HEX NYLOCK, 1/2-13 ZN, G8
14	3006201	12	NUT, 1/2-13 HEX GR. 8 ZP
15	FWL050088013	12	WASHER, LOCK - 1/2 SPLIT ZN
16	3039531	2	TUBE, SPACER GM 2014
17	3002169	1	WIRE, FISH
18	FWF050138014	14	WASHER, FLAT, 1/2" USS, ZN
19	EXIST_BOLT	2	SCREW, HX HD CAP 3/8-16 X 1-1/2 G5 ZN

INSTRUCTIONS

NOTE: Do Not Tighten Fasteners Until All Components Are Assembled.

1. Remove the bumper and bumper fasteners. Set aside for later reinstallation. The plastic bottom of the bumper must be trim off (later) as a slot for the Pushbar clearance.

2. Attach the PS sideplate (1) to the frame aligning the tow hook holes to the plate. Secure it with the two 5 inch-bolts provided. Insert the Spacer tubing (16) into one of the two long bolts above the tow-hook-internal-support bracket. Secure one existing short bolt from on the outside of the frame where only a single side of the tow hook bracket thread is available.

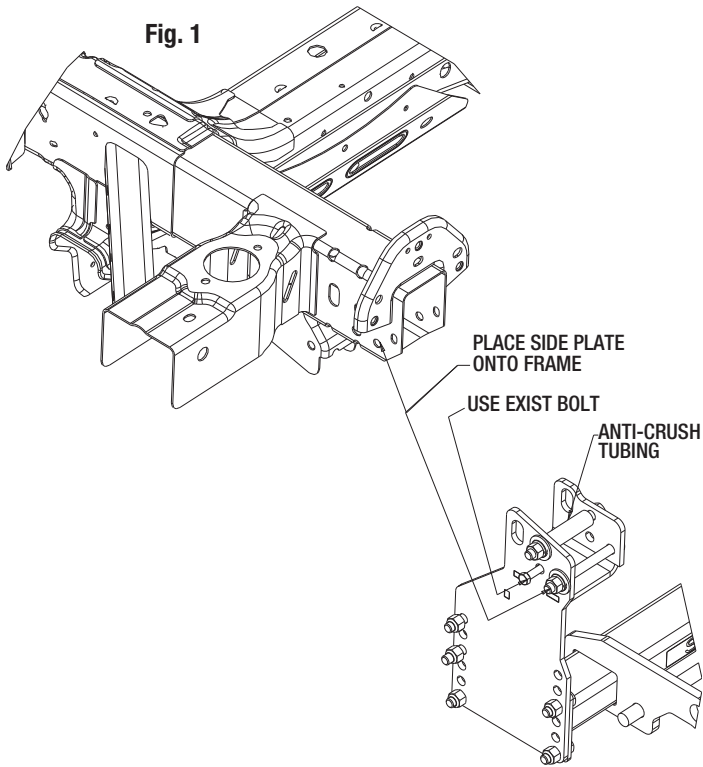

3. At the bottom of the frame near the triangular hole, secure to the frame of the truck with a carriage bolt (7), a rectangular spacer (6), a flat washer (18), a spring washer (15), and a nut (14). The existing hole may have to be enlarged for 1/2" bolt.

Fig. 2

INSERT CARRIAGE BOLT AND SPACER INSIDE FRAME
INSTALL WASHER AND NUT BELOW

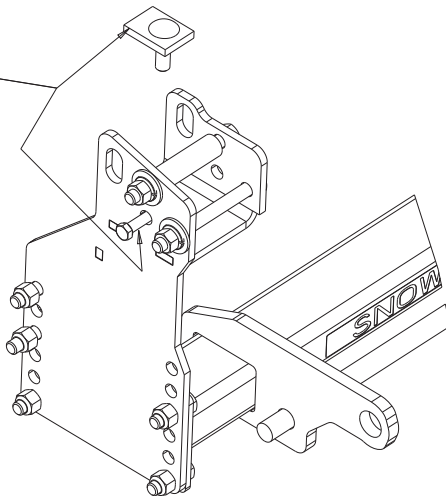

4. Repeat step 3-4 for the Driver Side, DS.

5. Install the PS Rear Brace (3) onto the Side plate (1). Using the bracket as a template, drill one of 2 holes on the side. Connect the Rear Brace (3) on to the frame. Install the bolt and washers as shown. At the bottom of the frame, enlarge existing hole next to the triangle - for 1/2" fastener. It may be helpful to use the fish wire (17) to insert the bolt here.

DRILL 1/2" HOLES

Fig. 3

ATTACH THE REAR BRACE ONTO THE FRAME

INSTALL NUT AND WASHER UNDER THE FRAME

ATTACH THE REAR BRACE ONTO THE SIDEPLATE BRACKET

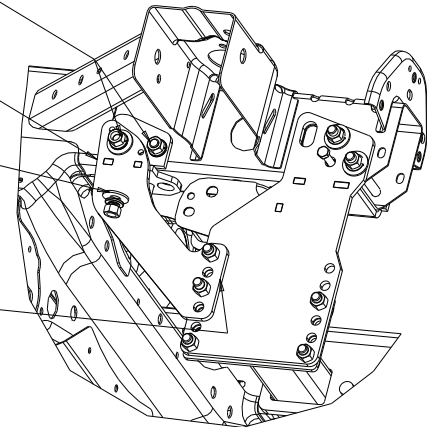



6. Repeat step 5 for Driver Side, DS.

7. Attach the Pushbar (5) onto the two Side-plates (1,2) using eight 1/2" bolt and eight nuts. **The center line of the push bar Cross Pin should be approximately 11" from the level ground. It may be necessary to notch the plastic valence to raise the pushbar up to the desired height. Failure to do so will result in uneven and premature blade wear. It is recommended to install a lift kit to achieve this height.**

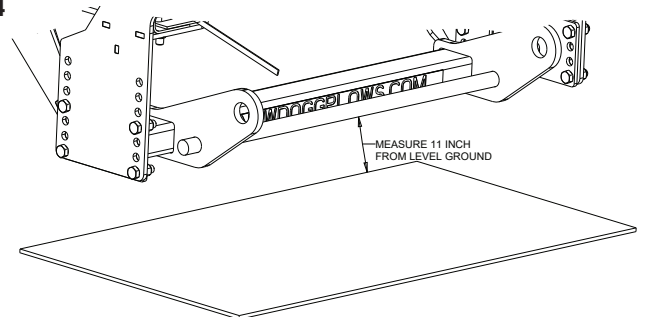
Fig. 4



8. Torque all fasteners as shown in the chart. Check and re-torque all fasteners after 5 hours of usage to ensure safe plow operation. Ensure all coolant lines and wires are clear from moving or hot components.

Recommended Fastener Torque Chart (ft.-lb.)			
Size	 SAE Grade 2	 SAE Grade 5	 SAE Grade 8
1/4-20	6	9	13
5/16-18	11	18	28
3/8-16	19	31	46
3/8-24	24	46	68
7/16-14	30	50	75
1/2-13	45	75	115
9/16-12	66	110	165
5/8-11	93	150	225
3/4-10	150	250	370
7/8-9	150	378	591
1-8	220	583	893

Metric Grade 8.8 (ft.-lb.)			
Size	Torque	Size	Torque
M6	7	M12	60
M8	17	M14	95
M10	35	M16	155

These torque values apply to fasteners except those noted in the instruction.

WARNING

- DO NOT under any circumstances disable, remove or relocate any sensors or components related to the operation of the air bags.
- Always follow the vehicle manufacturers' recommendations relating to snowplow installation.
- To comply with Federal Regulations and to assure a safe vehicle, the Front Gross Axle Weight Rating (FGAWR), Rear Gross Axle Weight Rating (RGAWR), and the Gross Vehicle Weight Rating (GAWR) must not be exceeded at any time.
- Due to the variety of equipment that can be installed on this vehicle, it is necessary to verify that the Front Gross Axle Weight Rating (FGAWR), Rear Gross Axle Weight Rating (RGAWR), and the Gross Vehicle Weight Rating (GAWR) are not exceeded at any time. This may require weighing the vehicle and adding ballast as necessary. It may also limit payload capacity of the vehicle. It is the operator's responsibility to verify that these ratings are not exceeded.

CAUTION

- Read all instructions prior to assembly
- It is critical that all fasteners be properly torqued for safe plow operation – see chart above.
- Fasteners should be retorqued after 5-8 hours of plow use

FULL ONE-YEAR WARRANTY

Manufacturer will repair, or at manufacturer's discretion will replace any part of this snowplow which proves to be defective in workmanship or material under normal use for a period of one year from the date of delivery to the original purchaser. Any cost incurred in returning the product to the supplier is the responsibility of the consumer.

EXCLUSIONS

Manufacturer shall not be liable for special, incidental, or consequential damages, or for damages resulting from lack of necessary maintenance, from misuse, abuse, acts of God, or alteration of the product. Some states do not allow the exclusion or limitation of incidental or consequential damages, so the above limitation or exclusion may not apply to you.