

HD/EX MOUNT KIT

16063100

DODGE RAM 1500 '06-'08



SnowDogg® Snowplow

TRUCK MOUNT INSTALLATION MANUAL

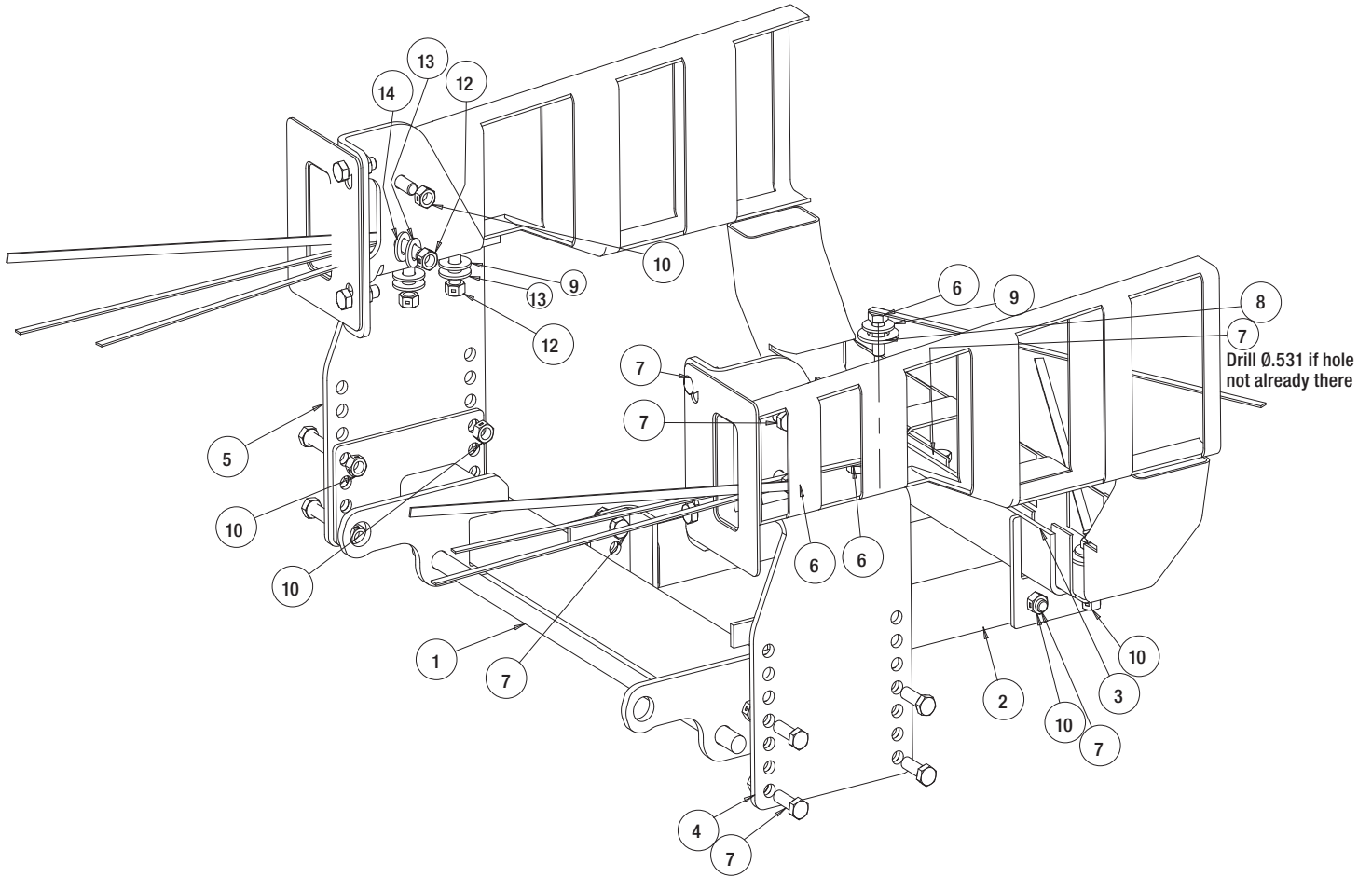

Bill of Materials

ITEM	PART NO.	QTY.	DESCRIPTION
1	16063102	1	Push Bar, HD Asy, Dodge 1/2 T
2	16063118	2	Armature, Tube Extension
3	16063113	1	Angle, X-Bar Asy Mnt Dodge 1/2 T
4	16063115	1	Bracket, Main DS Dodge 1/2 T
5	16063117	1	Bracket, Main PS Dodge 1/2 T
6	16801004	8	Screw, Hex HD, 1/2-13 x 1-1/2 Gr 5 w/HDL

ITEM	PART NO.	QTY.	DESCRIPTION
7	3006202	23	Screw, Hex HD - 1/2-13 x 1-1/2 Gr 8 ZN
8	FWF088175134	2	Washer, Flat 7/8" SAE ZN
9	FWF050138014	6	Washer, Flat, .500 x 1.38 x .14, ZN
10	3002397	25	Locknut, Hex 1/2-13, ZN Gr 8
11	-	1	Truck Frame
12	3006201	6	Nut, 1/2-13 Hex GR8 ZN
13	FWL050088013	6	Washer, Lock 1/2" Split ZN
14	FWF050106010	2	Washer, Flat 1/2" ZN

INSTRUCTIONS

1. Remove the bumper, bumper fasteners, and skid plate. Set aside for later reinstallation.
2. Remove the tow hooks if your vehicle is equipped with them and retain all the fasteners.
3. Hold the **PS Bracket** (4) up against the passenger side frame rail, aligning with the existing holes on the flange of the truck's frame. Secure the **Bracket** (4) using two 1/2-13 x 1.5 **Bolts** (7), two **locknuts** (10). Look at the bottom of the frame with two existing holes from the tow-hook and use the existing fasteners to secure the **Bracket** (4). If the holes are not there, drill them as needed.

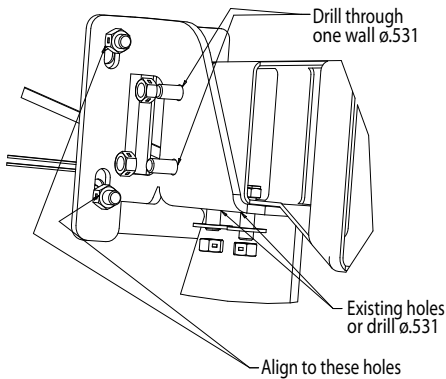

4. On the side of the frame, using the **Bracket** (4) as a template, drill through two holes on one side of the wall with $\text{Ø}0.531$ diameter clearance. Secure the **Bracket** using two 1/2" **Bolts** (7) and two **locknuts** (10).
5. Repeat Step number 2-4 for the **DS Bracket** (5).

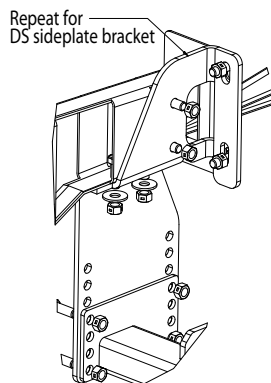

6. Mount the **Pushbar** (1) in place between the two side plates using eight 1/2-13 x 1.5 **bolts** (7) and eight 1/2 -13 **locknuts** (10). The centerline of the Pushbar cross pin should be approximately 9" to 10.5" from the ground. The air dam of the vehicle may need to be altered to accommodate this height. Improper mounting height will result in uneven cutting edge wear.

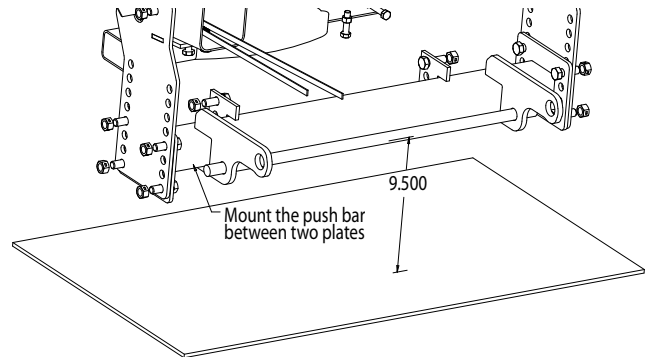

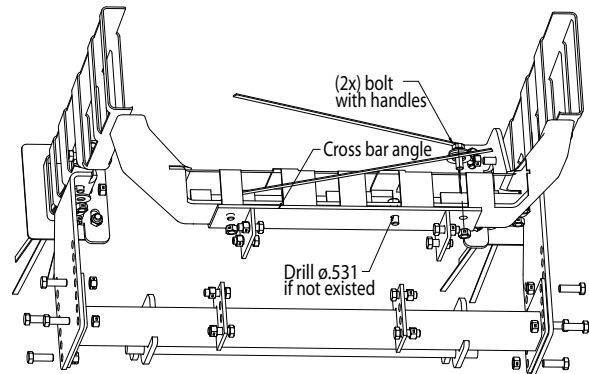

7. Install the **Cross Bar Angle** (3) to the cross member frame using two 1/2-13x1.5 **Bolt-sticks** (6) along with two 1/2-13 **locknuts** (10) and two 1/2" **washers** (9) and two 7/8" **washers** (8). Secure the third holes with a 1/2" **Bolts** (7) and one **locknut** (10).

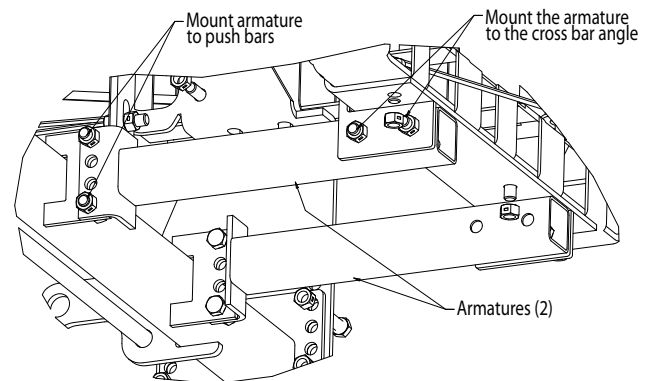

8. Secure two **Armatures** (2) to the **Pushbar** (1) using four 1/2-13x1.5 **bolts** (7) and four **locknuts** (10).



9. Secure two **Armatures** (2) to the **Cross Bar Angle** (3) using four 1/2" **bolts** (7), and four **locknuts** (10).
10. It may be helpful to route the plow and light control harnesses at this point, prior to bumper re-installation.
11. Torque all fasteners as shown in the chart. Check and re-torque all fasteners after 5 hours of usage to ensure safe plow operation. Ensure all coolant lines and wires are clear of the moving or hot components and tie up as necessary.

Recommended Fastener Torque Chart (ft.-lb.)			
Size	 SAE Grade 2	 SAE Grade 5	 SAE Grade 8
1/4-20	6	9	13
5/16-18	11	18	28
3/8-16	19	31	46
3/8-24	24	46	68
7/16-14	30	50	75
1/2-13	45	75	115
9/16-12	66	110	165
5/8-11	93	150	225
3/4-10	150	250	370
7/8-9	150	378	591
1-8	220	583	893

Metric Grade 8.8 (ft.-lb.)			
Size	Torque	Size	Torque
M6	7	M12	60
M8	17	M14	95
M10	35	M16	155

These torque values apply to fasteners except those noted in the instruction.

WARNING

- DO NOT under any circumstances disable, remove or relocate any sensors or components related to the operation of the air bags.
- Always follow the vehicle manufacturers' recommendations relating to snowplow installation.
- To comply with Federal Regulations and to assure a safe vehicle, the Front Gross Axle Weight Rating (FGAWR), Rear Gross Axle Weight Rating (RGAWR), and the Gross Vehicle Weight Rating (GAWR) must not be exceeded at any time.
- Due to the variety of equipment that can be installed on this vehicle, it is necessary to verify that the Front Gross Axle Weight Rating (FGAWR), Rear Gross Axle Weight Rating (RGAWR), and the Gross Vehicle Weight Rating (GAWR) are not exceeded at any time. This may require weighing the vehicle and adding ballast as necessary. It may also limit payload capacity of the vehicle. It is the operator's responsibility to verify that these ratings are not exceeded.

CAUTION

- Read all instructions prior to assembly
- It is critical that all fasteners be properly torqued for safe plow operation – see chart above.
- Fasteners should be retorqued after 5-8 hours of plow use

FULL ONE-YEAR WARRANTY

Manufacturer will repair, or at manufacturer's discretion will replace any part of this snowplow which proves to be defective in workmanship or material under normal use for a period of one year from the date of delivery to the original purchaser. Any cost incurred in returning the product to the supplier is the responsibility of the consumer.

EXCLUSIONS

Manufacturer shall not be liable for special, incidental, or consequential damages, or for damages resulting from lack of necessary maintenance, from misuse, abuse, acts of God, or alteration of the product. Some states do not allow the exclusion or limitation of incidental or consequential damages, so the above limitation or exclusion may not apply to you.