

Packing List

# LED Combo Heavy Duty Headlight E7107

## Packing & Installation Manual

Version. E01-2020

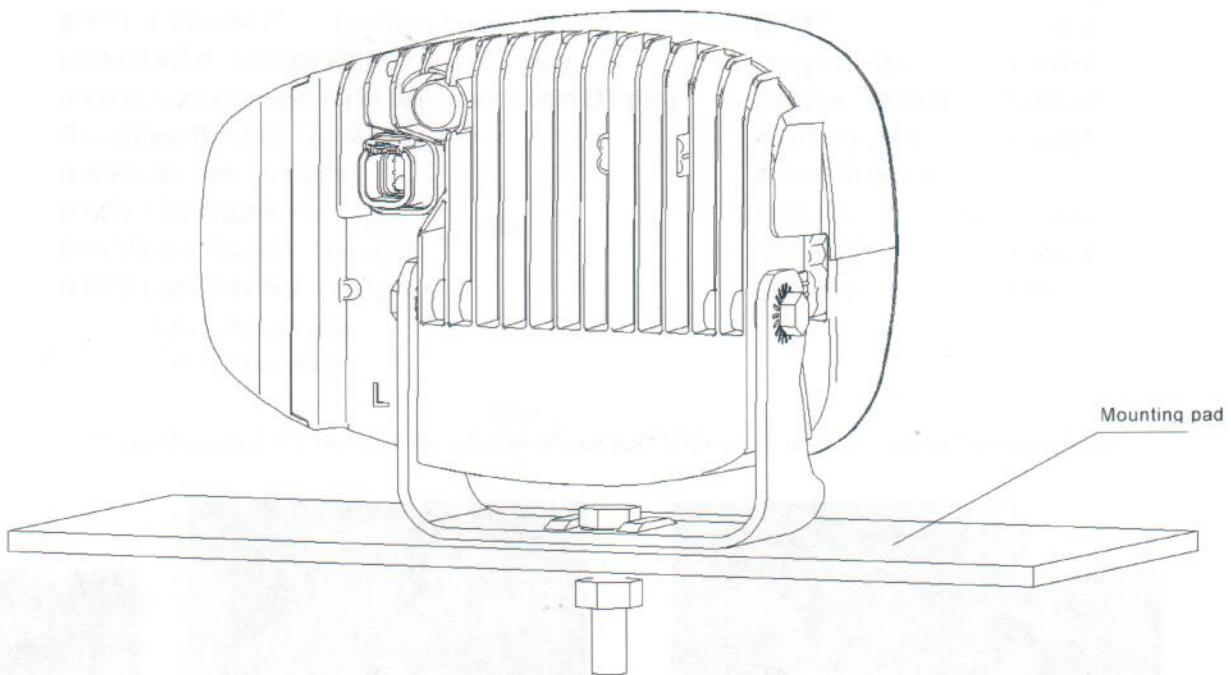

It is highly recommended that this manual be read carefully  
before installing LED Snow Plow Headlight.

This manual is only applicable for E7107 series.

Content in this manual might be updated, modified, or revised without prior notice.

If more details should be needed, please contact your representative(s)

## I. Packing List

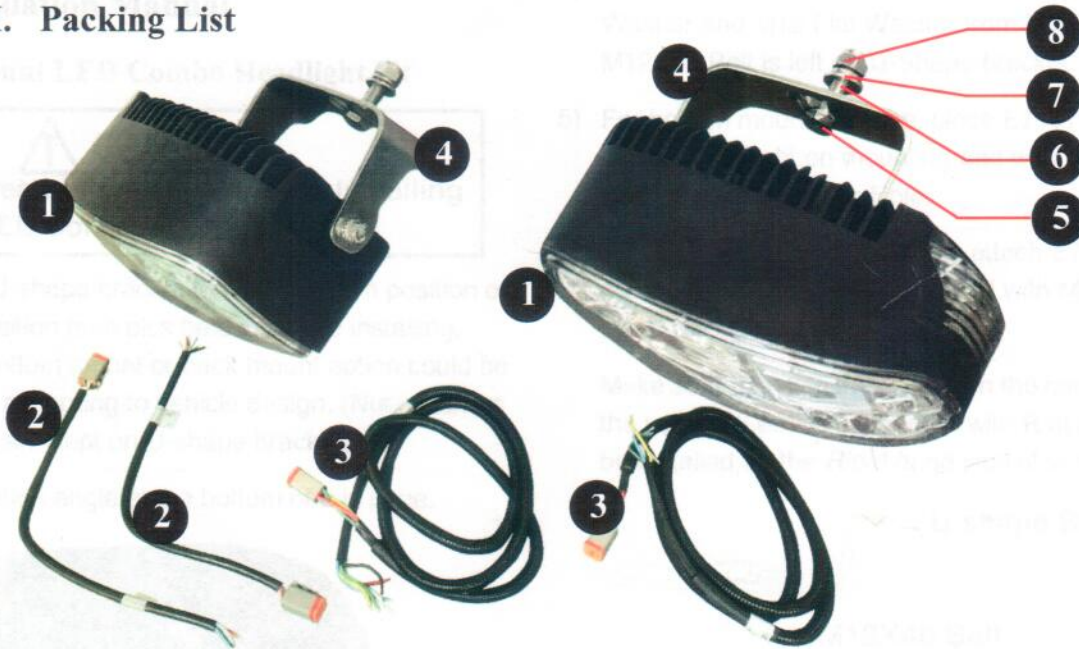

| Item  | Remarks         | Quantity |
|---|-----------------|----------|
| ① E7107 Combo LED Headlight body                    | (R / L)         | 1 pcs×2  |
| ② Short Wire Harness Kit with 6pin DT plug          | (approx. 40cm)  | 1 pcs×2  |
| ③ Long Wire Harness Kit in bellow with 6pin DT plug | (approx. 183cm) | 1 pcs×2  |
| ④ U shape Bracket (on light)                        | 4mm SUS304      | 1 pcs×2  |
| ⑤ M12×40 Bolt (on light)                            | 40mm SUS304     | 1 pcs×2  |
| ⑥ M12 Flat Washer (on light)                        | SUS304          | 1 pcs×2  |
| ⑦ M12 Lock Washer (on light)                        | SUS304          | 1 pcs×2  |
| ⑧ M12 Lock Hex Nut (on light)                       | SUS304          | 1 pcs×2  |

**R** for right hand side

**L** for left hand side

**Note:** Please find **R/L** mark on the rear side of each light body before installing, like in the picture below.

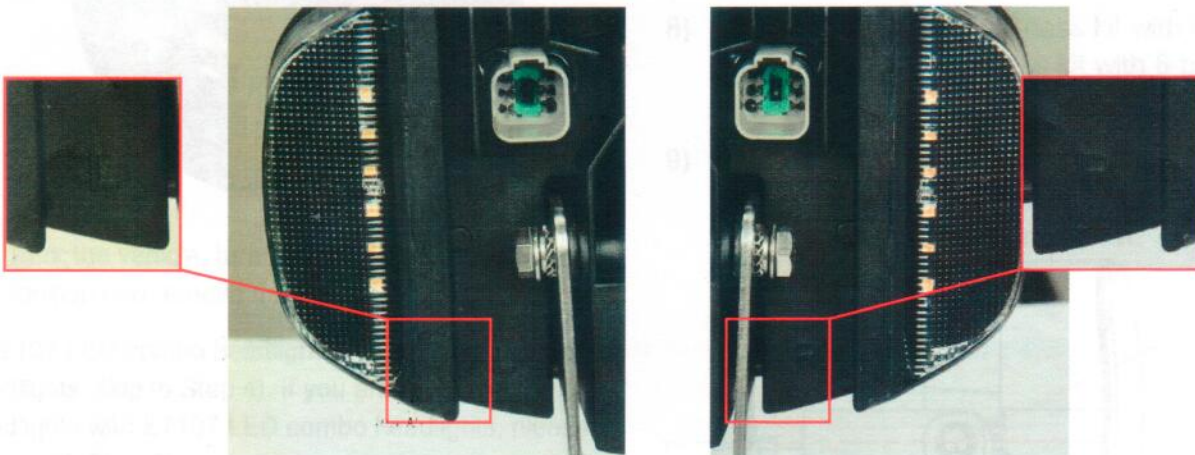

Left hand side

Right hand side



## II. Installation Manual

### 2.1. Mount LED Combo Headlight kit



#### CAUTION

Please read this manual before installing E7107 LED Combo Headlights kit.

- 1) Rotate U-shape bracket to either bottom position or back position (see pics below) before installing. Either bottom mount or back mount option could be decided according to vehicle design. (Nut, washers and bolt are kept on U-shape bracket).

See rotation angle at the bottom of this page.



Bottom mount

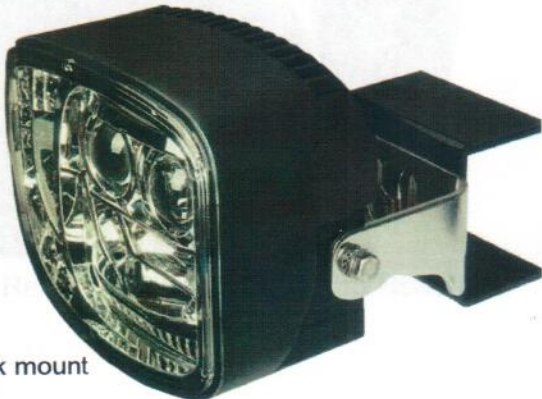

Back mount

- 2) Park the vehicle, turn off the control and turn off the ignition and remove the key.

If E7107 LED combo headlights will be used as original headlights, skip to Step 4). If you are replacing existing headlights with E7107 LED combo headlights, please go on with Step 3).

- 3) Remove existing halogen headlight from vehicle by disconnecting wire harness kit.

- 4) Unscrew M12 Lock Hex Nut, remove M12 Lock Washer and M12 Flat Washer from M12X40 Bolt; M12X40 Bolt is left on U-Shape bracket.

- 5) For bottom mount purpose, place E7107 LED combo headlight on mounting pad with M12X40 Bolt insert through the Hole;

While for back mount purpose, attach E7107 LED combo headlight to mounting pad with M12X40 Bolt insert through the Hole.

Make sure to install the E7107 on the correct side of the vehicle (i.e. E7107 marked with **R** at rear should be installed on the *Right hand side* of vehicle)

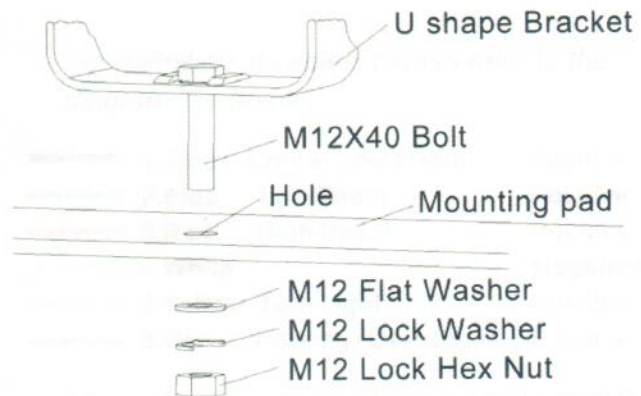

- 6) On the U-shape bracket with M12X40 bolt passing through the hole, install one M12 Flat Washer and M12 Lock Washer and M12 Lock Hex Nut. Tighten the M12 Lock Hex Nut with Hex wrench.

- 7) Repeat steps 4)-6) (or steps 3)-6) if E7107s are replacing existing headlights) to install the other side of E7107 LED combo headlight.

- 8) Select the Long wire harness kit with 6-pin DT plug or Short wire harness kit with 6-pin DT plug according to vehicle needs.

- 9) Install the DT plug wire harness kit to the rear of E7107 LED combo headlight. Please refer to 2.2. Installing Wire Harness Kit.

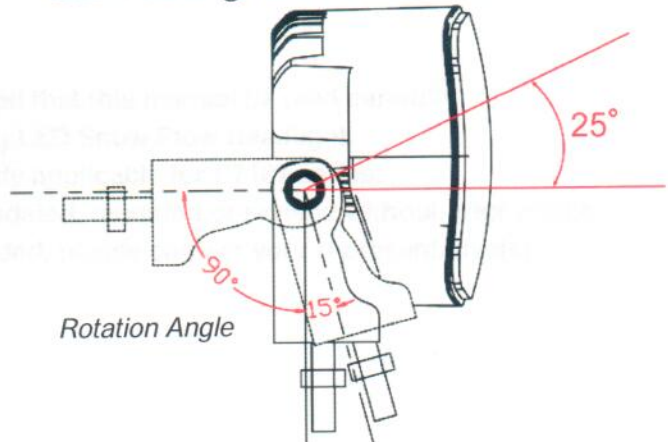

Rotation Angle



10) Aim E7107 LED combo headlight beam according to vehicle needs by rotating E7107 combo headlight body. Tighten the screws and hex nuts when E7107 LED combo headlights are correctly aimed. Installation height of E7107 might be different from one vehicle to another.

## 2.2. Installing Wire Harness Kit



### CAUTION

Please make sure if de-icing function is configured according to your orders.



### NOTE

If configured, DE-ICING function switches automatically when ambient temperature less than 5 °C



Rear of E7107 LED Combo Headlight



### CAUTION

Voltage input to this headlight must be 10~30VDC;







Make sure the output voltage from vehicle is 10~30VDC before power on.



### WARNING

For de-icing version E7107, power supply cable of PARKING light from vehicle is recommended to be 18AWG with load of not less than 10A, or better cable.

For definition of cables, please refer to the diagram like below.

|   |                           |            |
|---|---------------------------|------------|
|  | 1.Black: Corner Low Beam  | Positive ⊕ |
|  | 2.Blue: Low Beam.         | Positive ⊕ |
|  | 3.Red: High Beam          | Positive ⊕ |
|  | 4.White:                  | Negative ⊖ |
|  | 5.Yellow: Turn Light      | Positive ⊕ |
|  | 6.Green: Parking+De-icing | Positive ⊕ |

Corner Low Beam could either be in parallel connection with Low Beam as constant lighting of front corners;

Or Corner Low Beam could be controlled with an independent switch according to local homologations, so that Corner Low Beam could illuminate the front corners when needed. Independent switch is recommended to be prepared by customers according to vehicles.



It is highly recommended that this manual be read carefully before installing LED Snow Plow Headlight.

This manual is only applicable for E7107 series.

Content in this manual might be updated, modified, or revised without prior notice.

If more details should be needed, please contact your representative(s)