

# MD MOUNT KIT

## 16061155

FORD 250SD/350/450/550 '99-'07

FORD EXCURSION '99-'02



# SnowDogg™ Snowplow

## TRUCK MOUNT INSTALLATION MANUAL

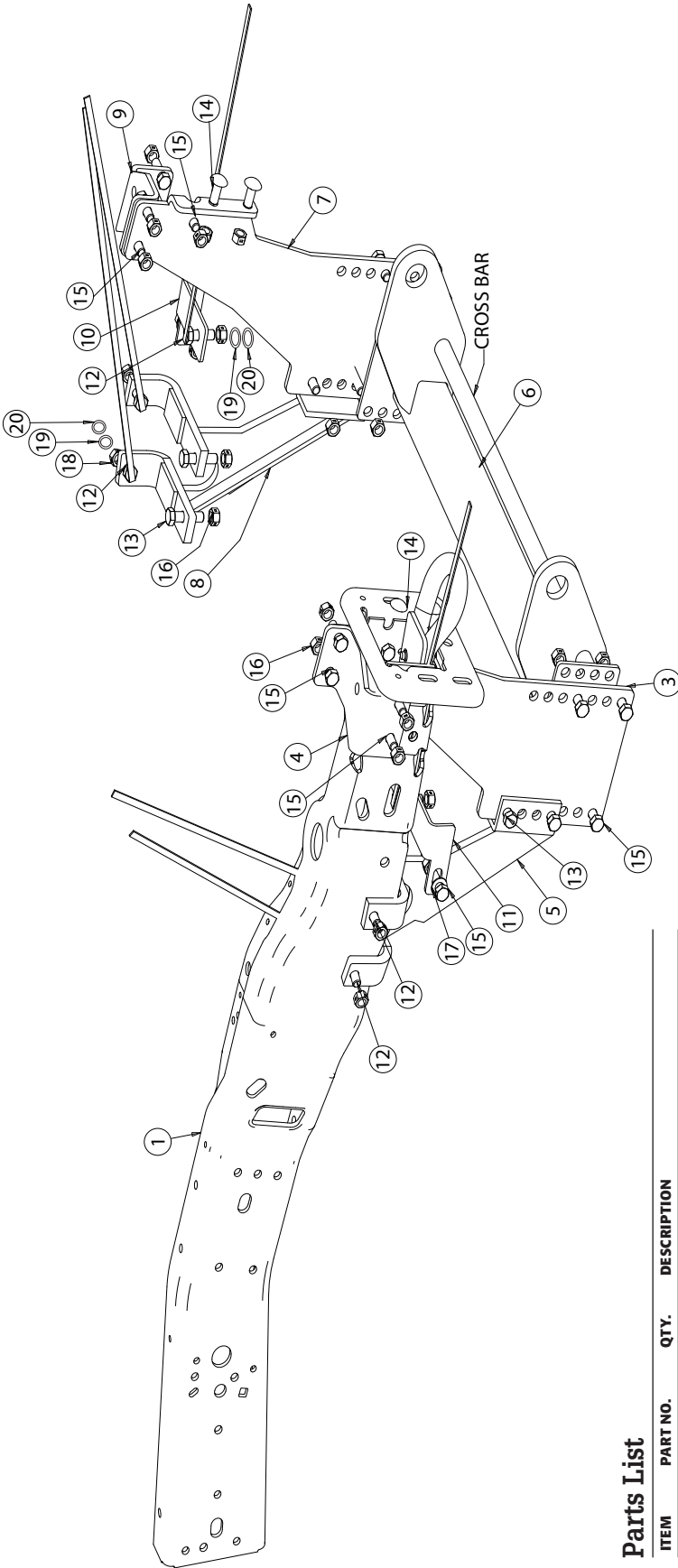

**Parts List**

ITEM	PART NO.	QTY.	DESCRIPTION
1	-	1	Frame
2	-	1	Frame
3	16161170	1	Mount, Ford F-250/350, PS
4	16061180	1	Plate, Upper Support Assy, PS
5	16061174	1	Mount, Rear Bracket, F-250, PS
6	16061157	1	Pushbar, Ford Mount
7	16061172	1	Mount, Ford F-250/350, DS
8	16061176	1	Mount, Rear Bracket F-250, DS
9	16061182	1	Plate, Upper Support Assy, DS
10	16061158	1	Bracket, Bumper, DS
11	16061160	1	Bracket, Bumper, PS
12	16801004	6	Screw, Hex HD, 1/2-13 x 1-1/2 w/HDL Gr. 5
13	3001384	8	Screw, Hex CAP, 1/2-13 x 2" ZN Gr. 5
14	3012580	4	Bolt, Carriage 1/2-13 x 1.25 Z Gr. 5
15	3006202	18	Screw, Hex HD 1/2-13 x 1-1/2 ZC Gr. 8
16	3002397	30	Locknut, Hex 1/2-13, ZN Gr. 8
17	FWF050106010	2	Washer, Flat, 1/2" SAE, ZN
18	3006201	6	Nut, 1/2-13 Hex GR 8 ZN
19	FWL050088013	6	Washer, Lock 1/2" Split ZN
20	FWF050106010	8	Washer Flat, 1/2" ZN

## INSTRUCTIONS

1. Remove the bumper and bumper fasteners. Set aside for later reinstallation.
2. Remove the "Blocker Beam" that is mounted between the frame horns. Disconnect the rubber air deflector from the blocker beam. Unbolt and remove the Blocker Beam and tow hooks from the truck frame. The tow hook mounting bolts will be reinstalled.

**Note: The BlockerBeam must be reinstalled if the plow mount is removed, and must be transferred when the vehicle is sold or traded.**

3. Hold the FORD Mount F250/350 passenger side [PS] plate (3) up against the frame, aligning with the existing bumper holes. Loosely install the two carriage bolts (14) and tighten them later when ready.

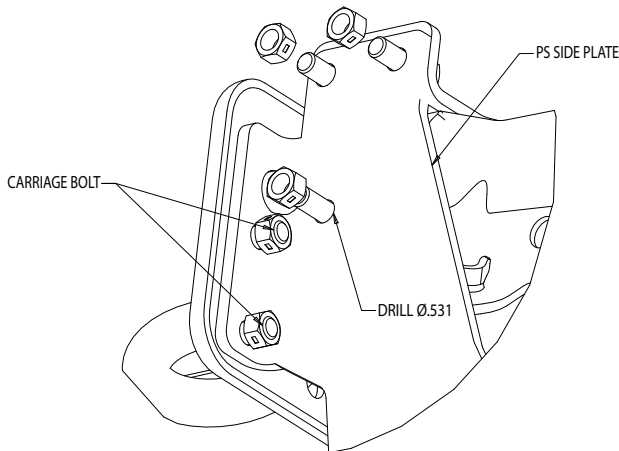

4. Attach the Upper Support Plate to the Side Plate [PS] (4) with two bolts (15). Using this item as template, drill two holes diameter 0.531" and fasten them with two locknuts (16).

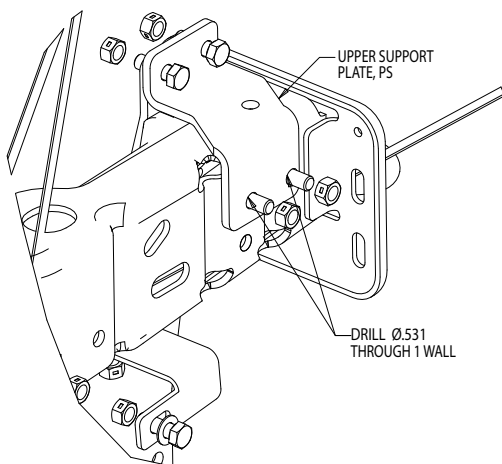

5. Remove and discard the two sway-bar bracket bolts and nut-clips from the sway-bar bracket (05-07 models).
6. Remove the sway-bar U-bracket and enlarge the holes diameter to 0.531" (05-07 models).

7. Reinstall the sway-bar U-bracket over the bushing and install two ½-13 x 2" (15) hex head bolts through the top of the sway-bar bracket. The rear arm of the mount should fit over the U-bracket. Install two ½-13 locknuts (16) from the bottom.

8. Attach the Mount rear bracket [PS] onto the main plate with two bolts and nuts. (step # 5-8 pic).

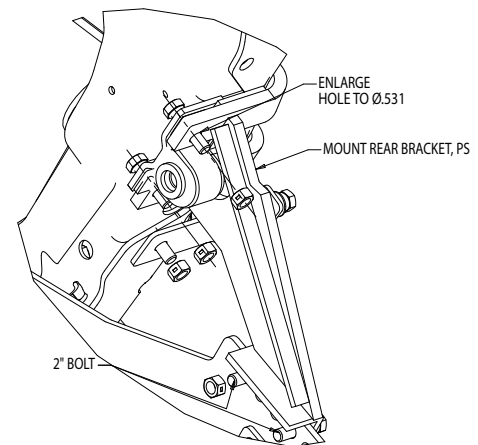

9. Hold the Mount rear bracket onto the frame and use it as a template to drill 2 holes 0.531". Install the ½"-13 x 1.5 bolts with lock nuts in the appropriate location.

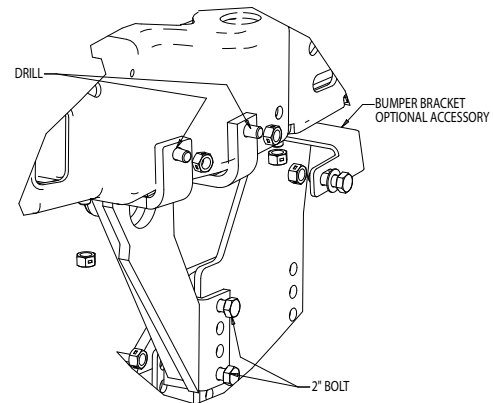



10. Install the bumper mounting bracket as shown using ½-13 x 1.5" bolts & the special welded bolts w/ handle (12).

11. Repeat step 3-9 for driver side installation.

12. Mount the pushbar in place in place between the two side plates using eight ½-13 x 1.5 bolts and eight ½-13 locknuts. The centerline of the pushbar cross pin should be approximately 9.5" from the ground. The air dam of the vehicle may need to be altered to accommodate this height. Improper mounting height will result in uneven cutting edge wear.

13. It may be helpful to route the plow and light control harnesses at this point, prior to bumper re-installation.

14. Torque all fasteners as shown in the chart. Check and re-torque all fasteners after 5 hours of usage to ensure safe plow operation. Ensure all coolant lines and wires are clear of the moving or hot components and tie up as necessary.

<b>Recommended Fastener Torque Chart (ft.-lb.)</b>			
Size	 SAE Grade 2	 SAE Grade 5	 SAE Grade 8
1/4-20	6	9	13
5/16-18	11	18	28
3/8-16	19	31	46
3/8-24	24	46	68
7/16-14	30	50	75
1/2-13	45	75	115
9/16-12	66	110	165
5/8-11	93	150	225
3/4-10	150	250	370
7/8-9	150	378	591
1-8	220	583	893

<b>Metric Grade 8.8 (ft.-lb.)</b>			
Size	Torque	Size	Torque
M6	7	M12	60
M8	17	M14	95
M10	35	M16	155

These torque values apply to fasteners except those noted in the instruction.

**WARNING**

- DO NOT under any circumstances disable, remove or relocate any sensors or components related to the operation of the air bags.
- Always follow the vehicle manufacturers' recommendations relating to snowplow installation.
- To comply with Federal Regulations and to assure a safe vehicle, the Front Gross Axle Weight Rating (FGAWR), Rear Gross Axle Weight Rating (RGAWR), and the Gross Vehicle Weight Rating (GAWR) must not be exceeded at any time.
- Due to the variety of equipment that can be installed on this vehicle, it is necessary to verify that the Front Gross Axle Weight Rating (FGAWR), Rear Gross Axle Weight Rating (RGAWR), and the Gross Vehicle Weight Rating (GAWR) are not exceeded at any time. This may require weighing the vehicle and adding ballast as necessary. It may also limit payload capacity of the vehicle. It is the operator's responsibility to verify that these ratings are not exceeded.

**CAUTION**

- Read all instructions prior to assembly
- It is critical that all fasteners be properly torqued for safe plow operation – see chart above.
- Fasteners should be retorqued after 5-8 hours of plow use

**FULL ONE-YEAR WARRANTY**

Manufacturer will repair, or at manufacturer's discretion will replace any part of this snowplow which proves to be defective in workmanship or material under normal use for a period of one year from the date of delivery to the original purchaser. Any cost incurred in returning the product to the supplier is the responsibility of the consumer.

**EXCLUSIONS**

Manufacturer shall not be liable for special, incidental, or consequential damages, or for damages resulting from lack of necessary maintenance, from misuse, abuse, acts of God, or alteration of the product. Some states do not allow the exclusion or limitation of incidental or consequential damages, so the above limitation or exclusion may not apply to you.