

MD MOUNT KIT

16061165

FORD '08+ 250/350/450/550



SnowDogg™ Snowplow

TRUCK MOUNT INSTALLATION MANUAL

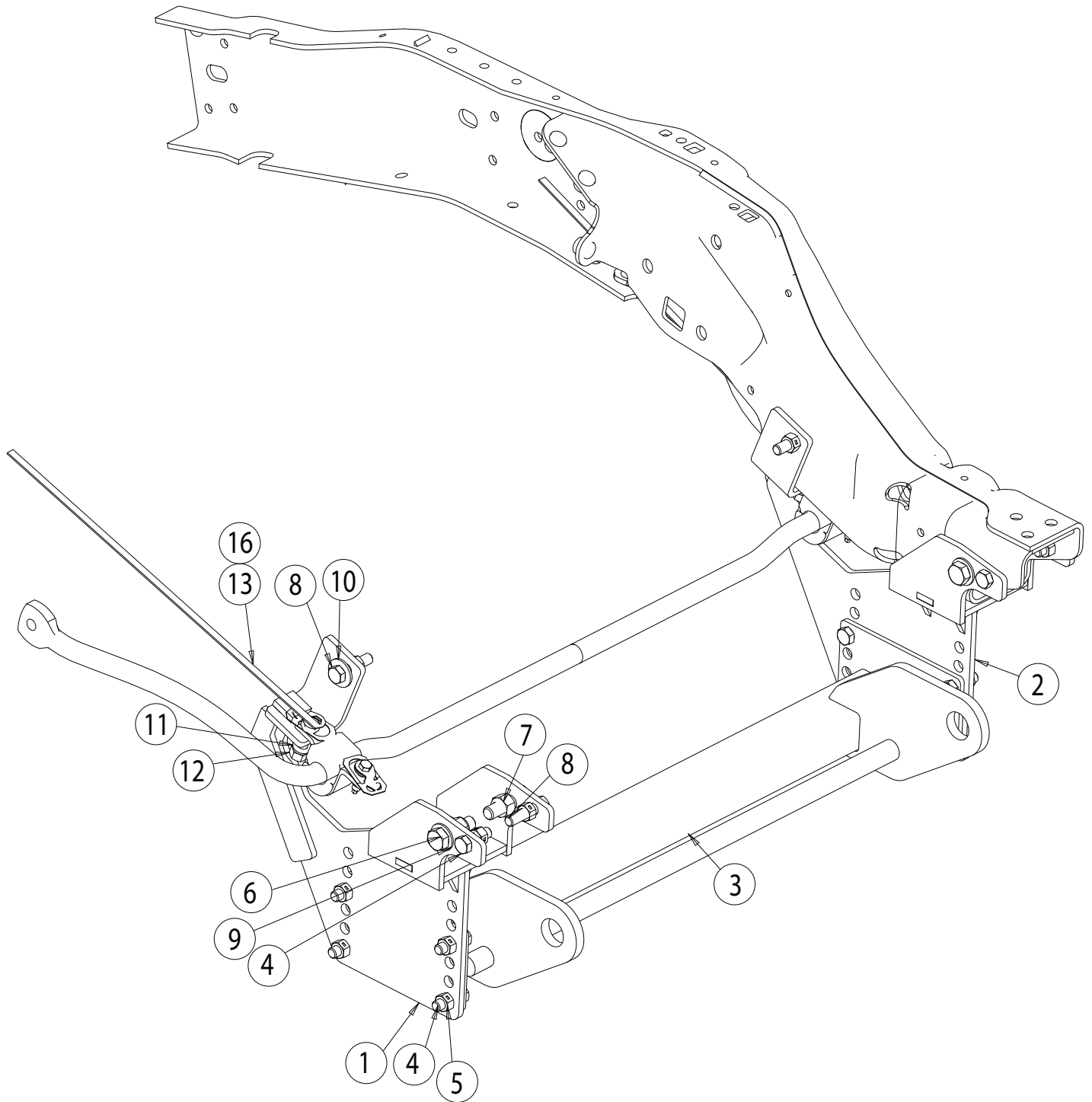

Parts List

ITEM	PART NO.	QTY.	DESCRIPTION
1	16061183	1	Bracket, Ford 2008+ SD, PS
2	16061184	1	Bracekt, Ford 2008+ SD, DS
3	16061167A	1	Pushbar, Ford Mount
4	3006202	10	Screw, Hex HD, 1/2-13 x 1-1/2 Gr. 8 ZN
5	3002397	14	Locknut, Hex 1/2-13, Gr. 8 ZN
6	FCS063011200	4	Screw, Hex Cap, 5/8-11 x 2 Gr. 5 ZN
7	3001247	4	Nut, Hex Nylock, 5/8-11 SST
8	3001384	4	Screw, Hex Cap, 1/2-13 x 2" Gr. 5 ZN

ITEM	PART NO.	QTY.	DESCRIPTION
9	FWF063131095	4	Washer, 5/8 SAE Flat, ZN
10	FWF050138014	2	Washer, Flat, .500 x 1.38 x .14, ZN
11	FWL050088011	4	Washer, Heavy Helical Spring Lock, 1/2", Blk Oxide
12	3006201	2	Nut, 1/2-13 Hex Gr. 8 ZN
13	16801004	2	Screw, Hex HD, 1/2-13 x 1-1/2 Gr. 5 w/HDL
14	3016993	3	Spacer, Bushing 3/4
15	3016995	3	Screw, M8x40mm
16	16801005	2	Screw, 2" Long w/HDL

INSTRUCTIONS

1. Remove the bumper and bumper fasteners. Set aside for later reinstallation. The hood release latch is connected to the bumper-remove prior to bumper removal to prevent damage to the latch.
2. Remove the rear bolt from the passenger side stabilizer bar mounting bracket. The bolt has a hex end for easy removal with a socket or wrench. Drill the existing hole to $\text{\O} .531$. This bolt will NOT be reused.

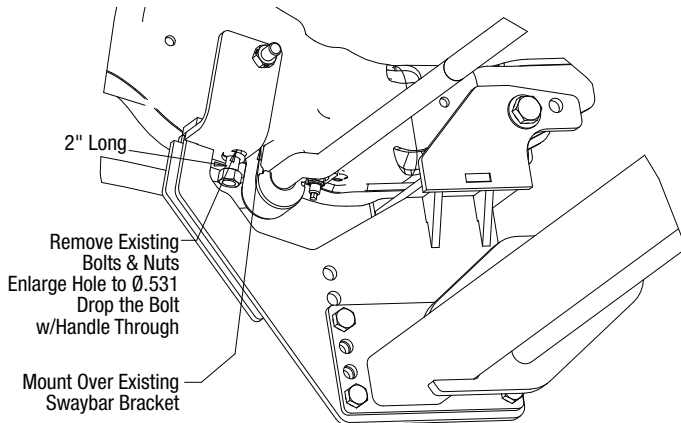

3. Drop **ONE $\frac{1}{2}$ " BOLT WITH HANDLE (13)** through the newly drilled hole from the inside of the frame.
4. Hold the **PS MOUNT PLATE (1)** up against the frame bottom and side. Loosely install in the rear using the previously installed Bolt with handle, **ONE $\frac{1}{2}$ " LOCK WASHER (11)**, and **ONE $\frac{1}{2}$ " HEX NUT (12)** and in the front **ONE $\frac{5}{8}$ "X2 HEX HEAD BOLT (6)**, **ONE $\frac{5}{8}$ " FLAT WASHER (9)** and **ONE $\frac{5}{8}$ " LOCK NUT.**

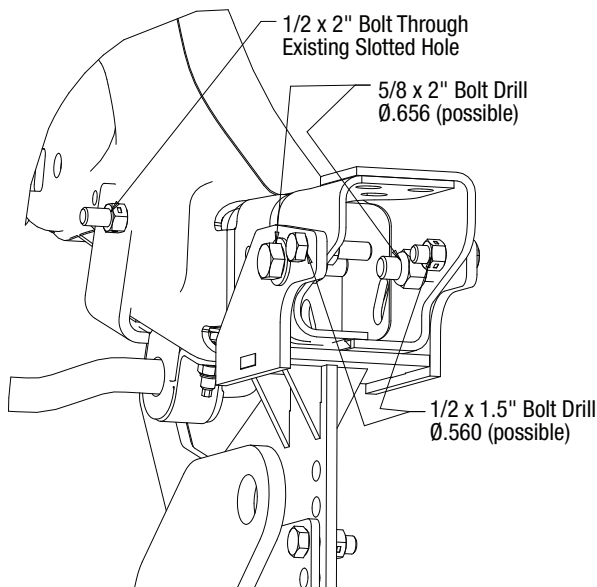

5. Insert **ONE $\frac{1}{2}$ "X2" HEX HEAD BOLT (8)** with **ONE $\frac{1}{2}$ " FLAT WASHER (10)** through the slotted hole towards the rear of the frame that aligns with the existing hole in the mount bracket. Secure with **ONE $\frac{1}{2}$ " LOCK NUT (5)**.

6. At the front sides of the frame, if necessary, drill a $\text{\O} .531$ hole for $\frac{1}{2}$ " fasteners and a $\text{\O} .656$ hole for $\frac{5}{8}$ " fasteners using the mount plate as a template. Use **ONE $\frac{5}{8}$ "X2" HEX HEAD BOLT (6)**, **ONE $\frac{5}{8}$ " FLAT WASHER (9)** and **ONE $\frac{5}{8}$ " LOCK NUT (7)** for the larger hole, and **ONE $\frac{1}{2}$ "X1- $\frac{1}{2}$ " HEX HEAD BOLT (4)** and **ONE $\frac{1}{2}$ " LOCK NUT (5)** for the smaller hole.

NOTE: The $\frac{1}{2}$ " hole on the inside face of the passenger side frame may not align (on certain models) with the existing hole on the mount bracket. This bolt/nut is optional and may be omitted. If used, a $\frac{1}{2}$ "x2" bolt and locknut should be installed.

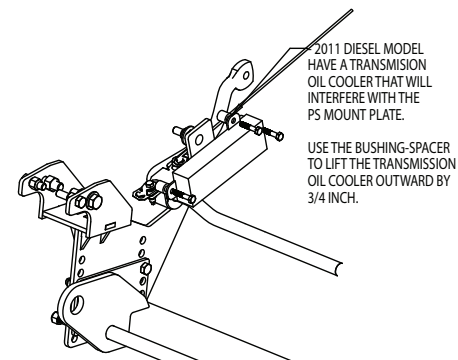

7. For 2011 and newer diesel model, there is a transmission oil cooler mounted on the passenger side frame that interferes with the PS MOUNT PLATE (1). It is necessary to install the **THREE BUSHING SPACERS** and **THREE M8X40 BOLTS**, to have room for the installed bolts-heads.

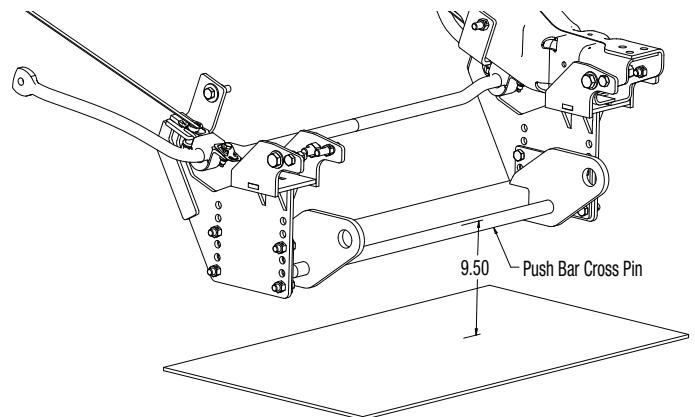

8. Repeat steps 2-6 for the **DS MOUNT PLATE (item 2)**.
9. Mount the **PUSHBAR (3)** in place between the **PS** and **DS MOUNT PLATES** using **EIGHT $\frac{1}{2}$ "-13X1- $\frac{1}{2}$ " BOLTS (4)** and **EIGHT $\frac{1}{2}$ "-13 LOCK NUTS (5)**. The centerline of the pushbar crosspin should be approximately 9.5" from the ground. The air dam of the vehicle may need to be altered to accommodate this height. Improper mounting height will result in uneven cutting edge wear.



10. Torque all fasteners as shown in the chart. Check and re-torque all fasteners after 5 hours of usage to ensure safe plow operation. Ensure all coolant lines and wires are clear of moving or hot components and secure as necessary.
11. It may be helpful to route the plow and light control harnesses at this point, prior to bumper reinstallation.
12. Reinstall the bumper and all accessories as needed.

Recommended Fastener Torque Chart (ft.-lb.)			
Size	 SAE Grade 2	 SAE Grade 5	 SAE Grade 8
1/4-20	6	9	13
5/16-18	11	18	28
3/8-16	19	31	46
3/8-24	24	46	68
7/16-14	30	50	75
1/2-13	45	75	115
9/16-12	66	110	165
5/8-11	93	150	225
3/4-10	150	250	370
7/8-9	150	378	591
1-8	220	583	893
Metric Grade 8.8 (ft.-lb.)			
Size	Torque	Size	Torque
M6	7	M12	60
M8	17	M14	95
M10	35	M16	155
These torque values apply to fasteners except those noted in the instruction.			

WARNING

- DO NOT under any circumstances disable, remove or relocate any sensors or components related to the operation of the air bags.
- Always follow the vehicle manufacturers' recommendations relating to snowplow installation.
- To comply with Federal Regulations and to assure a safe vehicle, the Front Gross Axle Weight Rating (FGAWR), Rear Gross Axle Weight Rating (RGAWR), and the Gross Vehicle Weight Rating (GAWR) must not be exceeded at any time.
- Due to the variety of equipment that can be installed on this vehicle, it is necessary to verify that the Front Gross Axle Weight Rating (FGAWR), Rear Gross Axle Weight Rating (RGAWR), and the Gross Vehicle Weight Rating (GAWR) are not exceeded at any time. This may require weighing the vehicle and adding ballast as necessary. It may also limit payload capacity of the vehicle. It is the operator's responsibility to verify that these ratings are not exceeded.

CAUTION

- Read all instructions prior to assembly
- It is critical that all fasteners be properly torqued for safe plow operation – see chart above.
- Fasteners should be retorqued after 5-8 hours of plow use

FULL ONE-YEAR WARRANTY

Manufacturer will repair, or at manufacturer's discretion will replace any part of this snowplow which proves to be defective in workmanship or material under normal use for a period of one year from the date of delivery to the original purchaser. Any cost incurred in returning the product to the supplier is the responsibility of the consumer.

EXCLUSIONS

Manufacturer shall not be liable for special, incidental, or consequential damages, or for damages resulting from lack of necessary maintenance, from misuse, abuse, acts of God, or alteration of the product. Some states do not allow the exclusion or limitation of incidental or consequential damages, so the above limitation or exclusion may not apply to you.