

MD MOUNT KIT

16061235

FORD '17+ 250/350/450/550



SnowDogg® Snowplow

TRUCK MOUNT INSTALLATION MANUAL

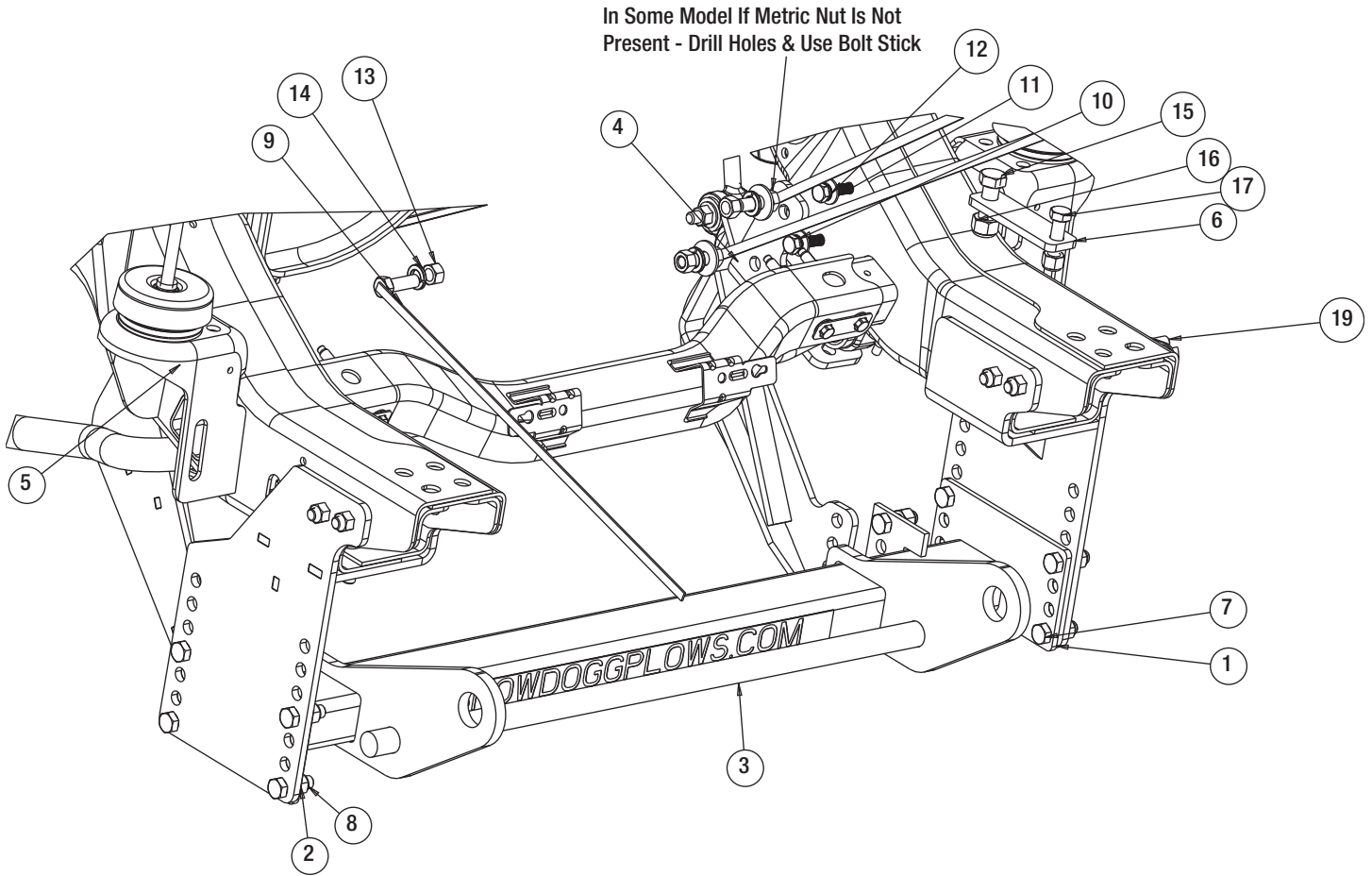

Parts List

ITEM	PART NO.	QTY.	DESCRIPTION
1	16061231	1	SIDEPLATE, DS
2	16061232	1	SIDEPLATE, PS
3	16062276	1	PUSHBAR, RAM 13+, W/ REAR MNT, MD
4	16061233	1	REAR BRACE, DS
5	16061234	1	REAR BRACE, PS
6	3029892	2	SPACER, INNER FRAME
7	3006202	12	SCREW, HEX HD - 1/2-13 X 1-1/2 GR 8 ZC
8	3002397	14	LOCKNUT, HEX NYLOCK, 1/2-13 ZN, G8
9	16801004	3	SCREW, HEX HD, 1/2-13x1-1/2 GR 5 W/HDL
10	3017707	2	SCREW, M10-1.5X40MM
11	FWF038100007	2	WASHER, FLAT 3/8 USS ZINC
12	FWL038069009	2	WASHER, LOCK RHS-3/8 ZN
13	3006201	3	NUT, 1/2-13 HEX GR. 8 ZP
14	FWL050088013	3	WASHER, LOCK - 1/2 SPLIT ZN
15	FCS063011200	2	SCREW, HEX CAP 5/8-11 X 2 GR5 ZN
16	3001247	2	NUT, HEX NYLOCK 5/8-11 SST
17	3001384	2	SCREW, HEX CAP 1/2-13 X 2" GR5 ZN
18	FWF050138014	3	WASHER, FLAT, 1/2" USS, ZN
19	-	1	TRUCK BOLT

INSTRUCTIONS

NOTE: Do Not Tighten Fasteners Until All Components Are Assembled.

1. Remove the bumper and bumper fasteners. Set aside for later reinstallation.
2. As shown in FIG 1 - on the Passenger side of the truck, remove and set aside the four nuts used on the existing bolt brackets on the inside and outside of the frame.
3. Secure the PS SIDE PLATE (2) to the frame using the bolt brackets and previously set aside nuts.
4. Use the bottom hole location on the DS SIDE PLATE as a template to drill a $\varnothing 9/16$ " hole through the front hole.
5. Install a 1/2"-13x2" Bolt (17) through the newly drilled hole and SPACER PLATE (6). Secure with a 1/2" Nut (8).
6. Install a 5/8-11"x2" Bolt (15) through the rear hole and secure with the SPACER PLATE and 5/8" Nut (16).

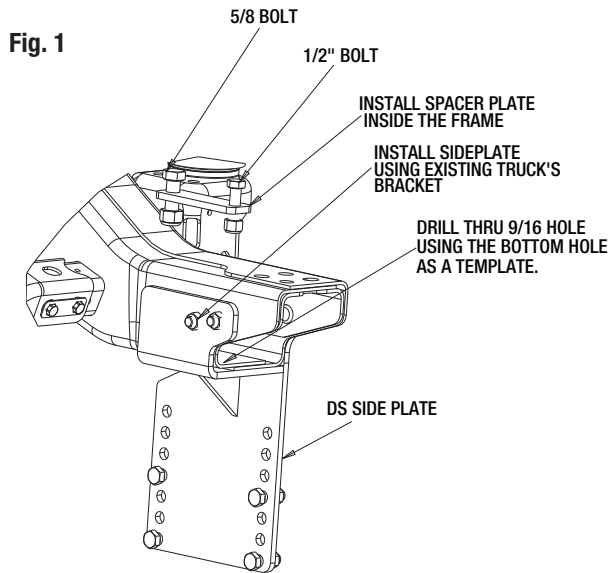

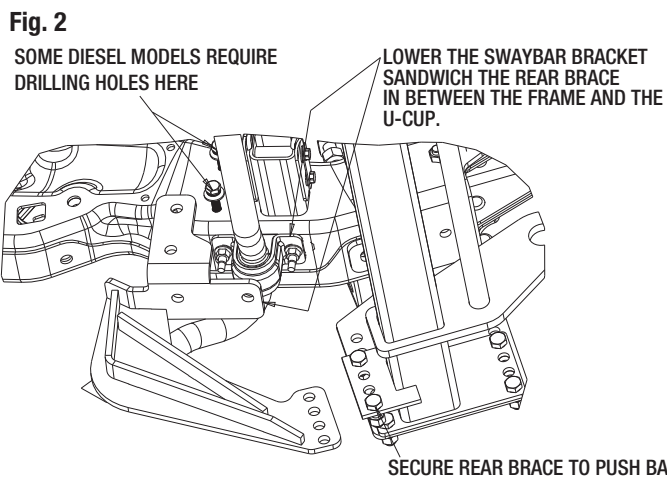

7. Repeat steps 2-6 to install the PS SIDEPLATE (2) onto the truck frame.
8. Loosely assemble the PUSHBAR to the SIDEPLATES using eight 1/2-13x1.5" SCREWS (7) and NUTS (8). See FIG 4. The center line of the push bar Cross Pin should be approximately 9.75" from the level ground. It may be necessary to notch the plastic valence to raise the pushbar up to the desired height. Failure to do so will result in uneven and premature blade wear.
9. Remove and set aside the nuts holding the DS swaybar bracket in place as shown in FIG 2.
10. Lower the swaybar bracket and install the DS REAR BRACE (4) in between the swaybar bracket and the truck frame.
11. Resecure the swaybar bracket with the nuts previously set aside.

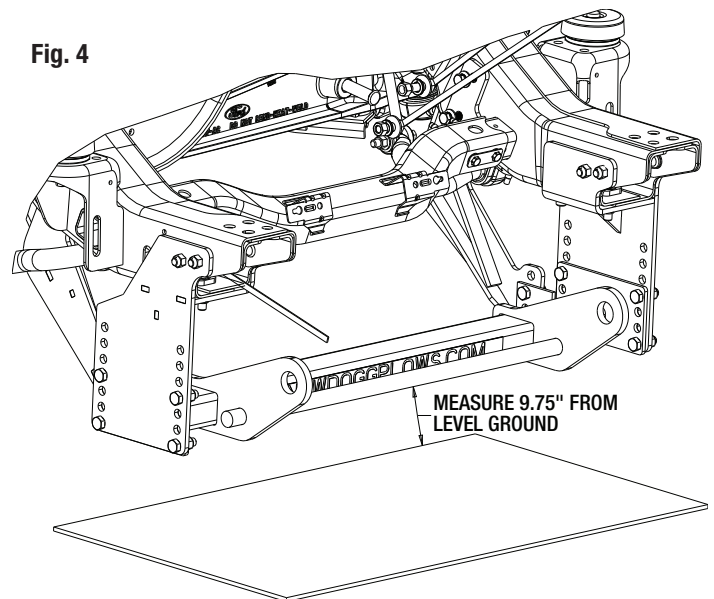
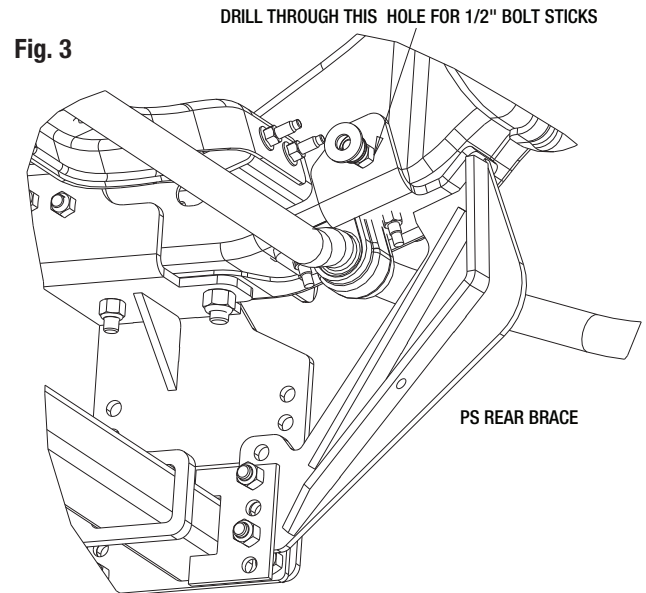

12. Attach the DS REAR BRACE to the PUSHBAR using the 1/2" fasteners already in place as shown in FIG 2.
13. Attach the DS REAR BRACE to the inside surface of the frame using two M10 BOLTS (10).
14. Repeat step 9-12 for PS REAR BRACE (5)
15. Use the holes in the PS REAR BRACE as a template to drill 2x $\varnothing 1/2$ " holes
16. Secure the PS REAR BRACE as shown in FIG 3 using 2x 1/2-13x1.5" Screws (9), 2x 1/2" LOCK WASHERS (14), and 2x 1/2" NUTS (13).



17. Torque all fasteners as shown in the chart. Check and re-torque all fasteners after 5 hours of usage to ensure safe plow operation. Ensure all coolant lines and wires are clear from moving or hot components.

Recommended Fastener Torque Chart (ft.-lb.)			
Size	 SAE Grade 2	 SAE Grade 5	 SAE Grade 8
1/4-20	6	9	13
5/16-18	11	18	28
3/8-16	19	31	46
3/8-24	24	46	68
7/16-14	30	50	75
1/2-13	45	75	115
9/16-12	66	110	165
5/8-11	93	150	225
3/4-10	150	250	370
7/8-9	150	378	591
1-8	220	583	893
Metric Grade 8.8 (ft.-lb.)			
Size	Torque	Size	Torque
M6	7	M12	60
M8	17	M14	95
M10	35	M16	155
These torque values apply to fasteners except those noted in the instruction.			

WARNING

- DO NOT under any circumstances disable, remove or relocate any sensors or components related to the operation of the air bags.
- Always follow the vehicle manufacturers' recommendations relating to snowplow installation.
- To comply with Federal Regulations and to assure a safe vehicle, the Front Gross Axle Weight Rating (FGAWR), Rear Gross Axle Weight Rating (RGAWR), and the Gross Vehicle Weight Rating (GAWR) must not be exceeded at any time.
- Due to the variety of equipment that can be installed on this vehicle, it is necessary to verify that the Front Gross Axle Weight Rating (FGAWR), Rear Gross Axle Weight Rating (RGAWR), and the Gross Vehicle Weight Rating (GAWR) are not exceeded at any time. This may require weighing the vehicle and adding ballast as necessary. It may also limit payload capacity of the vehicle. It is the operator's responsibility to verify that these ratings are not exceeded.

CAUTION

- Read all instructions prior to assembly
- It is critical that all fasteners be properly torqued for safe plow operation – see chart above.
- Fasteners should be retorqued after 5-8 hours of plow use

FULL ONE-YEAR WARRANTY

Manufacturer will repair, or at manufacturer's discretion will replace any part of this snowplow which proves to be defective in workmanship or material under normal use for a period of one year from the date of delivery to the original purchaser. Any cost incurred in returning the product to the supplier is the responsibility of the consumer.

EXCLUSIONS

Manufacturer shall not be liable for special, incidental, or consequential damages, or for damages resulting from lack of necessary maintenance, from misuse, abuse, acts of God, or alteration of the product. Some states do not allow the exclusion or limitation of incidental or consequential damages, so the above limitation or exclusion may not apply to you.