

# MD MOUNT KIT

## 16062255

DODGE '03 - '12 2500/3500



# SnowDogg® Snowplow

## TRUCK MOUNT INSTALLATION MANUAL

**For Model 2003-2009**

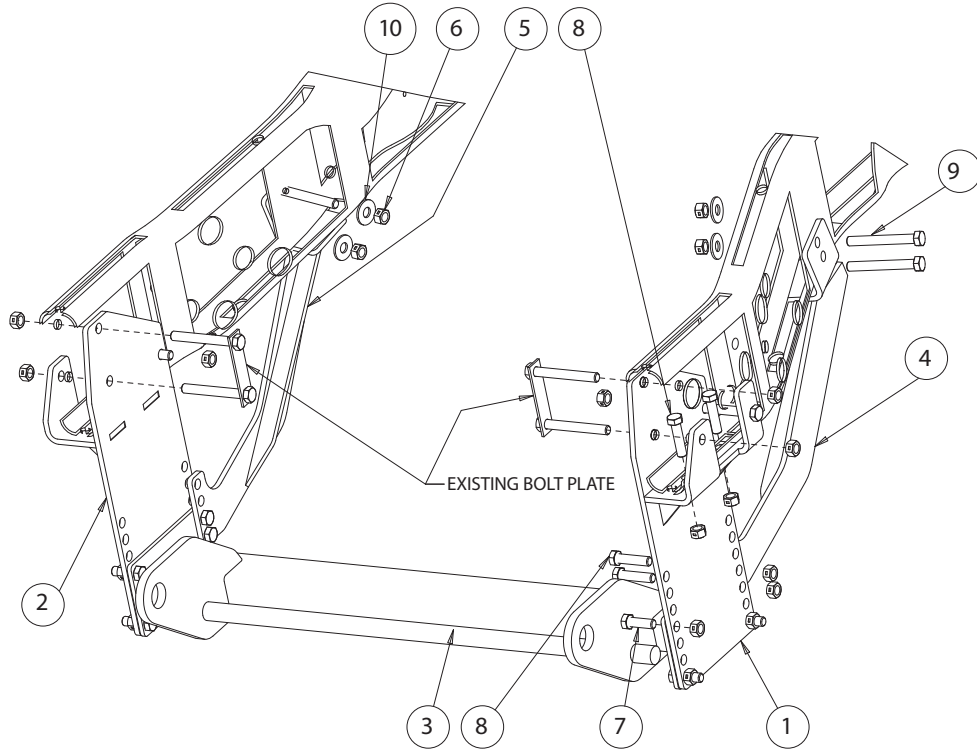

**For Model 2010+**

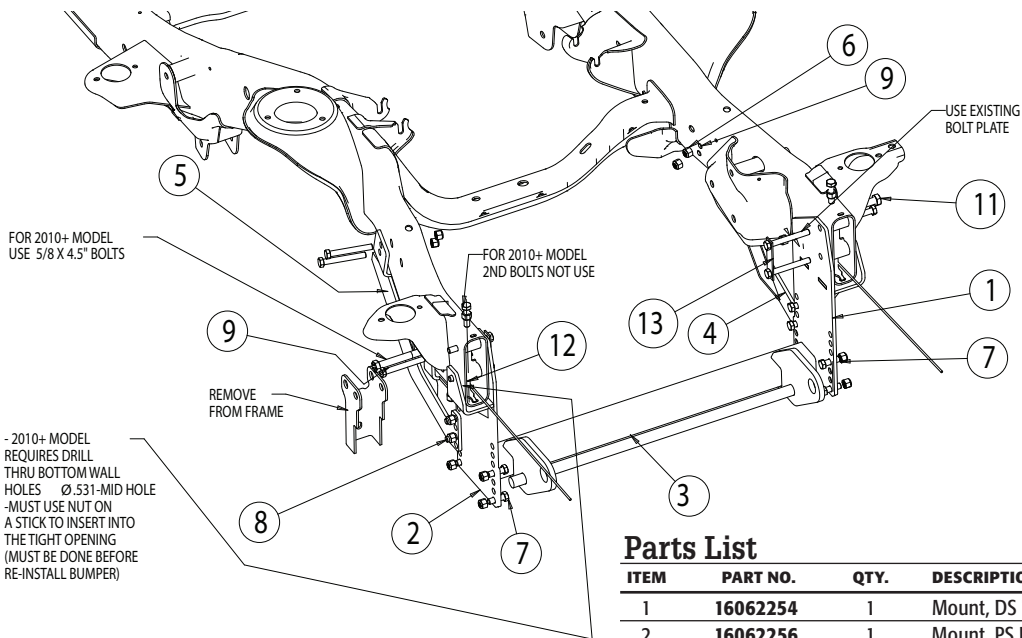

**Parts List**

ITEM	PART NO.	QTY.	DESCRIPTION
1	16062254	1	Mount, DS Dodge 2500/3500 03+
2	16062256	1	Mount, PS Dodge 2500/3500 03+
3	1602257	1	MD Pushbar
4	16062258	1	Bracket, Rear DS, 2500/3500
5	16062260	1	Bracket, Rear PS, 2500/3500
6	3002397	20	Locknut, Hex 1/2-13, ZN Gr. 8
7	3006202	6	Screw, Hex HD - 1/2-13 x 1-1/2 Gr. 8, ZN
8	3001127	8	Screw, HH Cap 1/2-13 x 2 Gr. 8 Black Ox
9	3011717	6	Screw, Hex Head Cap, 1/2-13 x 4 Gr. 8, ZN
10	FWF050138014	6	Washer, Flat .500 x 1.38 x .14, ZN
11	3004385	2	Screw, HH Cap, 5/8-11 x 4.5 Gr. 8, ZN Spcl
12	3011523	2	Nut, Hex, 1/2-13 w/Handle, Gr. 8

## INSTRUCTIONS

1. Remove the bumper from bumper brackets. Leave the bumper brackets on the frame.

2. Vehicles equipped with tow hooks will need the tow hooks and tow hook brackets removed (connected to bumper brackets). These will not be reused. They may be reinstalled if the plow mount is removed in the future.

3. Remove the PS BOLT PLATE (existing) from the PS BUMPER BRACKET. Retain bolt plate and fasteners. The BUMPER BRACKET is not shown on the figure for clarity.

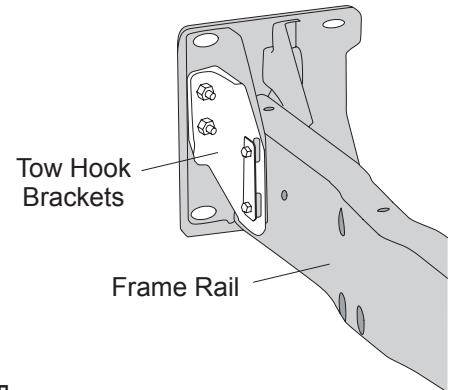

4. Hold the PS SIDE MOUNT PLATE against the frame, reinstalling the BOLT PLATE and fasteners. This will mount over the BUMPER BRACKET – slight modification of the BUMPER BRACKET on some models may be necessary.

5. Using the PS SIDE MOUNT PLATE as a template, drill two (2)  $\varnothing$ .531 holes through the bottom of the frame. Install two (2)  $\frac{1}{2}$ "-13x2" HEX HEAD BOLTS and two (2)  $\frac{1}{2}$ "-13 LOCK NUTS. The bottom tab of the frame spacer may need to be modified/removed to allow access to the bolts.

6. Using the PS SIDE MOUNT PLATE as a template, drill a  $\varnothing$ .531 holes for the rear hole position through the frame (aligning with the other side of the bracket). Install a (2)  $\frac{1}{2}$ "-13x4" HEX HEAD BOLT and a  $\frac{1}{2}$ "-13 LOCK NUT.

7. Loosely assembly the REAR PS BRACKET to the PS SIDE MOUNT PLATE as shown in the figure using two (2)  $\frac{1}{2}$ "-13x2" HEX HEAD BOLTS and two (2)  $\frac{1}{2}$ "-13x2" LOCK NUTS. This is for locating the rear bracket only, and will be disassembled, do not tighten.

8. Using the REAR PS BRACKET as a template (clamping in place if necessary), drill two (2)  $\varnothing$ .531 holes through the both sides of the frame. Install two (2)  $\frac{1}{2}$ "-13x4" HEX HEAD BOLTS, two (2)  $\frac{1}{2}$ " FLAT WASHERS, and two (2)  $\frac{1}{2}$ "-13 LOCK NUTS. DO NOT OVERTIGHTEN – DO NOT CRUSH FRAME.



9. Repeat steps 3-8 for the DS SIDE MOUNT PLATE.

10. Remove the fasteners connecting the REAR BRACKETS to the SIDE PLATES. These will be reused.

11. Mount the PUSHBAR in place between the two side plates using six (6)  $\frac{1}{2}$ "-13x1-1/2" HEX HEAD BOLTS and six (6)  $\frac{1}{2}$ "-13 LOCK NUTS in positions that will not interfere with the position of the REAR BRACKETS when they are remounted. The centerline of the PUSHBAR CROSSPIN should be approximately 9" from the ground. The air dam of the vehicle may need to be altered to accommodate this height. Improper mounting height will result in uneven cutting edge wear.

12. Remount the REAR BRACKETS (PS AND DS) to the SIDE PLATES on the inside face of the PUSHBAR, using two (2)  $\frac{1}{2}$ "-13x2" HEX HEAD BOLTS on each side. While there are four holes in the REAR BRACKETS, only two need to be used as shown in the figure.

13. Torque all fasteners as shown in the chart. Check and retorque all fasteners after 5 hours of usage to ensure safe plow operation. Ensure all coolant lines and wires are clear of moving or hot components and tie up as necessary.

<b>Recommended Fastener Torque Chart (ft.-lb.)</b>			
Size	 SAE Grade 2	 SAE Grade 5	 SAE Grade 8
1/4-20	6	9	13
5/16-18	11	18	28
3/8-16	19	31	46
3/8-24	24	46	68
7/16-14	30	50	75
1/2-13	45	75	115
9/16-12	66	110	165
5/8-11	93	150	225
3/4-10	150	250	370
7/8-9	150	378	591
1-8	220	583	893

<b>Metric Grade 8.8 (ft.-lb.)</b>			
Size	Torque	Size	Torque
M6	7	M12	60
M8	17	M14	95
M10	35	M16	155

These torque values apply to fasteners except those noted in the instruction.

### **WARNING**

- DO NOT under any circumstances disable, remove or relocate any sensors or components related to the operation of the air bags.
- Always follow the vehicle manufacturers' recommendations relating to snowplow installation.
- To comply with Federal Regulations and to assure a safe vehicle, the Front Gross Axle Weight Rating (FGAWR), Rear Gross Axle Weight Rating (RGAWR), and the Gross Vehicle Weight Rating (GAWR) must not be exceeded at any time.
- Due to the variety of equipment that can be installed on this vehicle, it is necessary to verify that the Front Gross Axle Weight Rating (FGAWR), Rear Gross Axle Weight Rating (RGAWR), and the Gross Vehicle Weight Rating (GAWR) are not exceeded at any time. This may require weighing the vehicle and adding ballast as necessary. It may also limit payload capacity of the vehicle. It is the operator's responsibility to verify that these ratings are not exceeded.

### **CAUTION**

- Read all instructions prior to assembly
- It is critical that all fasteners be properly torqued for safe plow operation – see chart above.
- Fasteners should be retorqued after 5-8 hours of plow use

### **FULL ONE-YEAR WARRANTY**

Manufacturer will repair, or at manufacturer's discretion will replace any part of this snowplow which proves to be defective in workmanship or material under normal use for a period of one year from the date of delivery to the original purchaser. Any cost incurred in returning the product to the supplier is the responsibility of the consumer.

### **EXCLUSIONS**

Manufacturer shall not be liable for special, incidental, or consequential damages, or for damages resulting from lack of necessary maintenance, from misuse, abuse, acts of God, or alteration of the product. Some states do not allow the exclusion or limitation of incidental or consequential damages, so the above limitation or exclusion may not apply to you.