

MD MOUNT KIT

16065115

TOYOTA TUNDRA '00-'06



SnowDogg™ Snowplow

TRUCK MOUNT INSTALLATION MANUAL

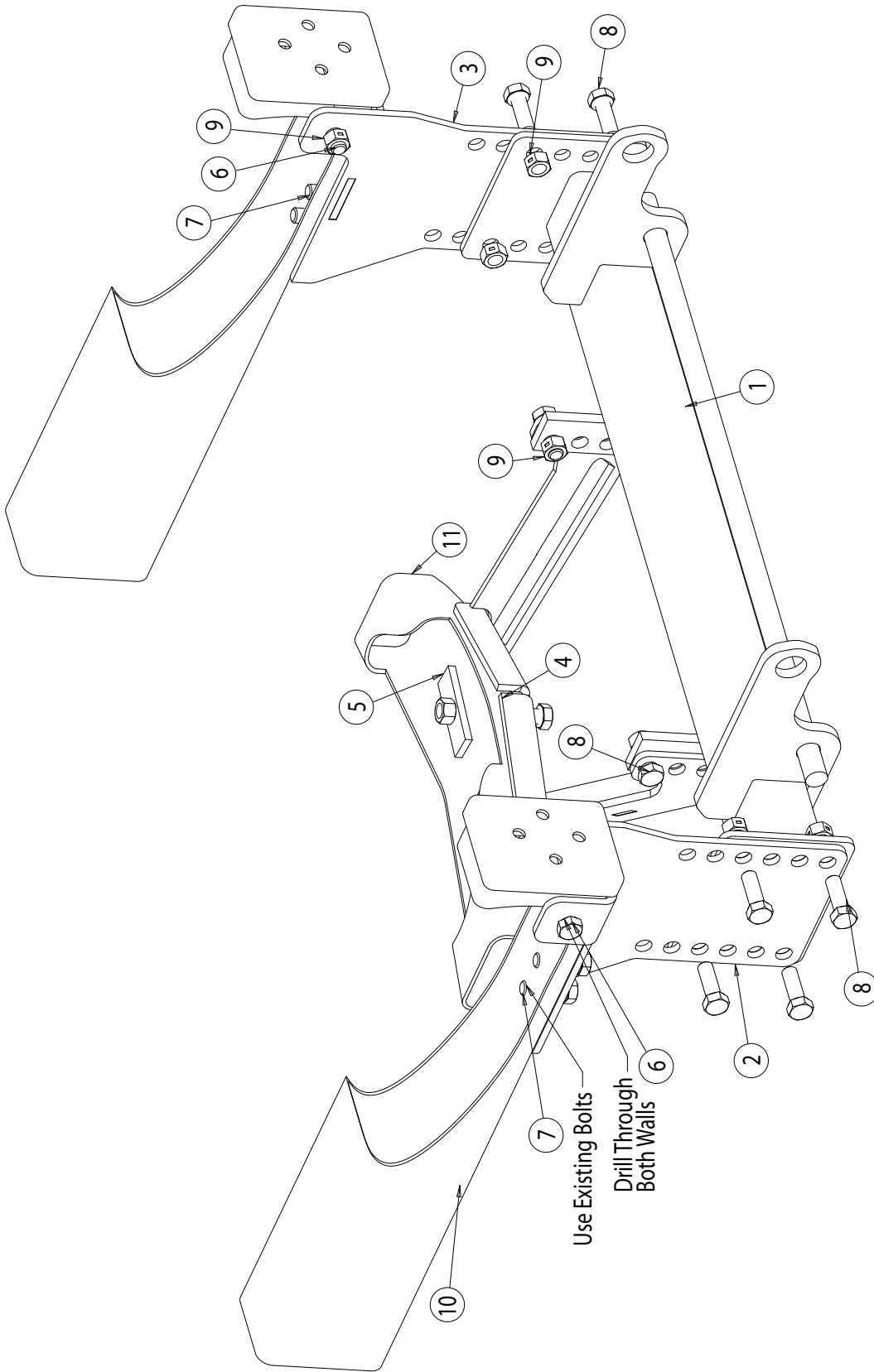

Parts List

ITEM	PART NO.	QTY.	DESCRIPTION
1	16062308	1	Pushbar, Chevy Colorado 04+
2	16065107	1	Plate, Side Asy Tundra 2000+ PS
3	16065109	1	Plate, Side Asy Tundra 2000+ DS
4	16065114	1	Bracket, Center Support
5	16065131	2	Plate, 1/2-13 Nut x 3 Weldment
6	3012583	2	Screw, HHC - 1/2-13 x 4.5 Gr. 5 ZN
7	16065115	4	Existing Tow-Hook-Bolt
8	3006202	14	Screw, Hex HD - 1/2-13 x 1-1/2 Gr. 8 ZN
9	3002397	14	Locknut, Hex 1/2-13, Zinc Gr. 8
10	-	2	PS & DS Truck Frame
11	-	1	Middle Truck Frame

INSTRUCTIONS

1. Remove the front bumper, bumper fasteners, and skid plate. Set aside for later reinstallation. For this vehicle, you may not have to remove the bumper if you can work around it.

2. Remove the tow hooks (if your vehicle option is equipped with them). Retain all the fasteners for later re-installation.

3. Hold the **PS Side Plate Bracket** (2) up against the passenger side frame rail, aligning with the existing holes from the tow-hook. Secure the bracket with the existing towhook bolts removed earlier. On the upper side of the frame, mark and drill through two walls with $\text{\O}531$ inch. Secure it with one 4.5" bolt and nut (6&9)

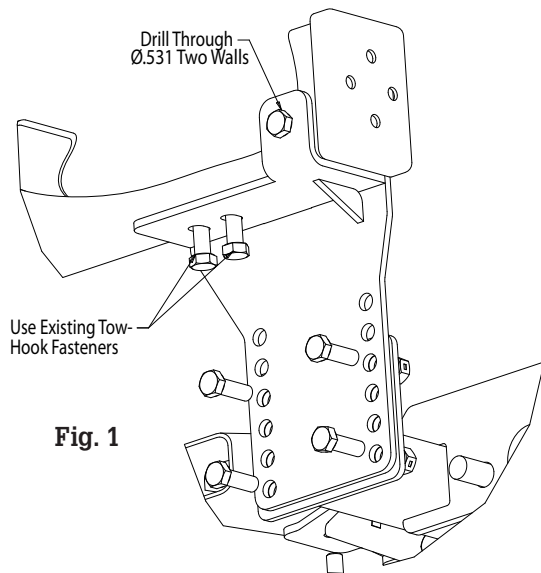

Fig. 1

4. Repeat step 3 above for **DS Side Plate Bracket** (3).

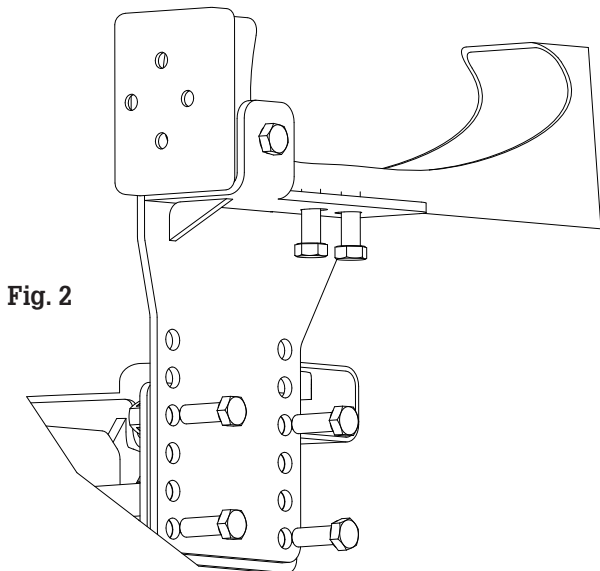

Fig. 2

5. Mount the **Pushbar** (1) in place between the two side plates using eight $\frac{1}{2}$ -13x1-1/2 bolts (8), and eight locknuts (9). The centerline of the pushbar crosspin should be approximately 9.5" from the ground. Improper mounting height will result in uneven cutting edge wear.

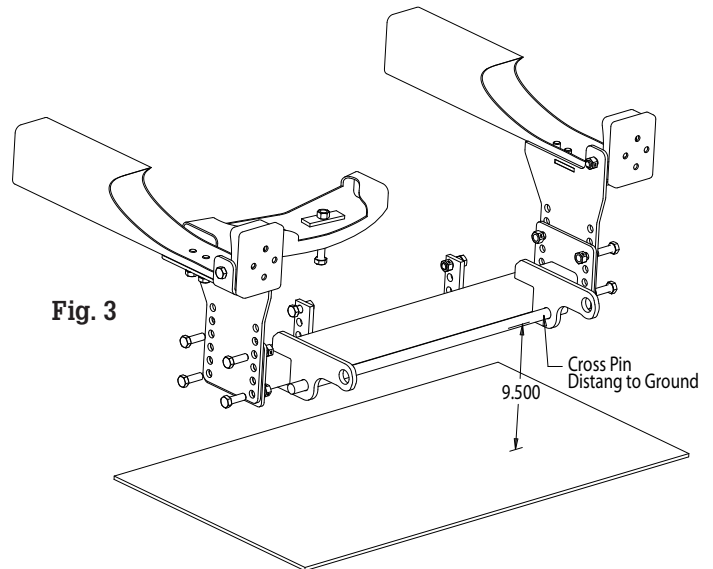

Fig. 3

6. Secure the **Center Bracket** (4) to the pushbar using four $\frac{1}{2}$ " bolts and nuts (8&9). In the back, secure the cross-member frame to the **Center Bracket** (4) with two $\frac{1}{2}$ " bolts and two **Nut Plates** (5).

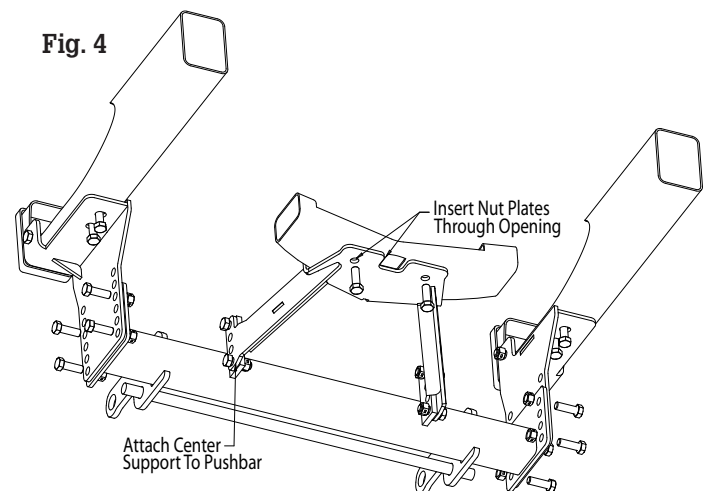





Fig. 4

7. Torque all fasteners as shown in the chart. Check and re-torque all fasteners after 5 hours of usage to ensure safe plow operation.

8. It may be helpful to route the plow and light control harnesses at this point, prior to bumper reinstallation.

9. Reinstall the bumper/air dam assembly and skid plate. The bumper/air dam and skid plate may need to be altered or omitted for reinstallation.

Recommended Fastener Torque Chart (ft.-lb.)			
Size	 SAE Grade 2	 SAE Grade 5	 SAE Grade 8
1/4-20	6	9	13
5/16-18	11	18	28
3/8-16	19	31	46
3/8-24	24	46	68
7/16-14	30	50	75
1/2-13	45	75	115
9/16-12	66	110	165
5/8-11	93	150	225
3/4-10	150	250	370
7/8-9	150	378	591
1-8	220	583	893

Metric Grade 8.8 (ft.-lb.)			
Size	Torque	Size	Torque
M6	7	M12	60
M8	17	M14	95
M10	35	M16	155

These torque values apply to fasteners except those noted in the instruction.

WARNING

- DO NOT under any circumstances disable, remove or relocate any sensors or components related to the operation of the air bags.
- Always follow the vehicle manufacturers' recommendations relating to snowplow installation.
- To comply with Federal Regulations and to assure a safe vehicle, the Front Gross Axle Weight Rating (FGAWR), Rear Gross Axle Weight Rating (RGAWR), and the Gross Vehicle Weight Rating (GAWR) must not be exceeded at any time.
- Due to the variety of equipment that can be installed on this vehicle, it is necessary to verify that the Front Gross Axle Weight Rating (FGAWR), Rear Gross Axle Weight Rating (RGAWR), and the Gross Vehicle Weight Rating (GAWR) are not exceeded at any time. This may require weighing the vehicle and adding ballast as necessary. It may also limit payload capacity of the vehicle. It is the operator's responsibility to verify that these ratings are not exceeded.

CAUTION

- Read all instructions prior to assembly
- It is critical that all fasteners be properly torqued for safe plow operation – see chart above.
- Fasteners should be retorqued after 5-8 hours of plow use

FULL ONE-YEAR WARRANTY

Manufacturer will repair, or at manufacturer's discretion will replace any part of this snowplow which proves to be defective in workmanship or material under normal use for a period of one year from the date of delivery to the original purchaser. Any cost incurred in returning the product to the supplier is the responsibility of the consumer.

EXCLUSIONS

Manufacturer shall not be liable for special, incidental, or consequential damages, or for damages resulting from lack of necessary maintenance, from misuse, abuse, acts of God, or alteration of the product. Some states do not allow the exclusion or limitation of incidental or consequential damages, so the above limitation or exclusion may not apply to you.