

MOUNT KIT

16067300

CASE 08+, CLUBCAR 07+,
HUSQVARNA 07+, NEW HOLLAND 07+



SnowDogg® Snowplow

TRUCK MOUNT INSTALLATION MANUAL

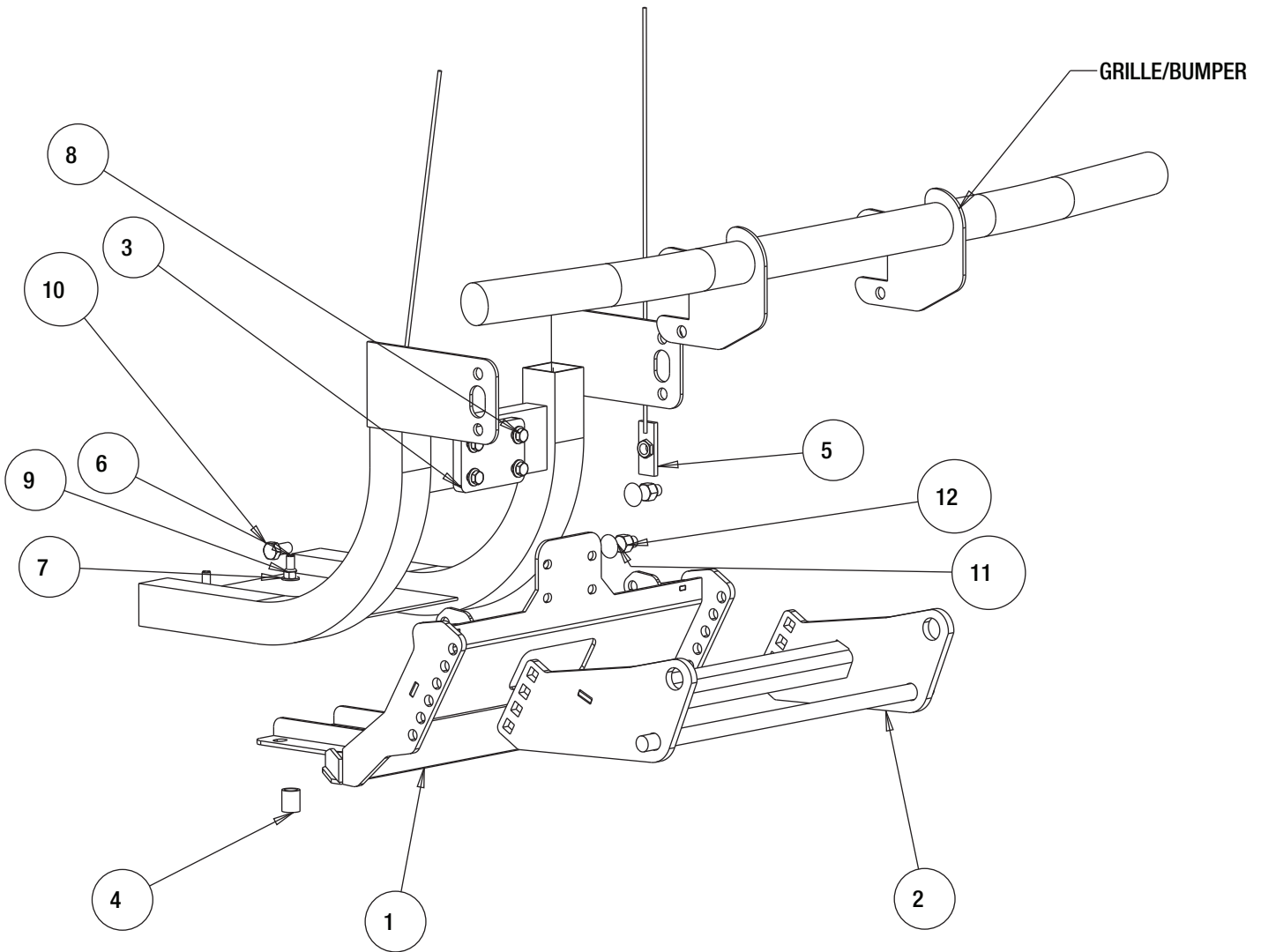

Parts List

ITEM	PART NO.	QTY.	DESCRIPTION
1	16067301	1	SKID PLATE, WELDMENT NEW HOLLAND
2	16067302	1	PUSHBAR, NEW HOLLAND
3	3031581	1	SPACER, THICK
4	3031582	2	SPACER, TUBING 3.45 LONG
5	16061121	2	NUT-PLATE, W/ HANDLE WELDMENT
6	FCS038016250G8	2	SCREW, HHC 3/8-16 X 2-1/2 GR8 ZP
7	FWF038081006	12	WASHER, FLAT 3/8 SAE ZINC
8	FCS038016350	4	SCREW, HHC-3/8-16 X 3.5 GR 5 ZN
9	FNE038016044	6	NUT, NYLOCK 3/8-16 X 7/16 ZINC
10	FCS050013100	2	SCREW, HHC-1/2-13 X 1 GR 5 ZN
11	3029357	4	BOLT, CARRIAGE 1/2-13 X 1.75 GR8 ZN
12	3002397	4	LOCKNUT, HEX NYLOCK, 1/2-13 ZN, G8

INSTRUCTIONS

1. Remove the front Bumper by removing the 4 bolts that held the bumper into place. Set aside for later reinstallation.
2. Remove four bolts from the vehicle front skid plate. The plastic skid plate will not be re-used for this installation. Remove the bottom two bolts from the rear. See fig 1.

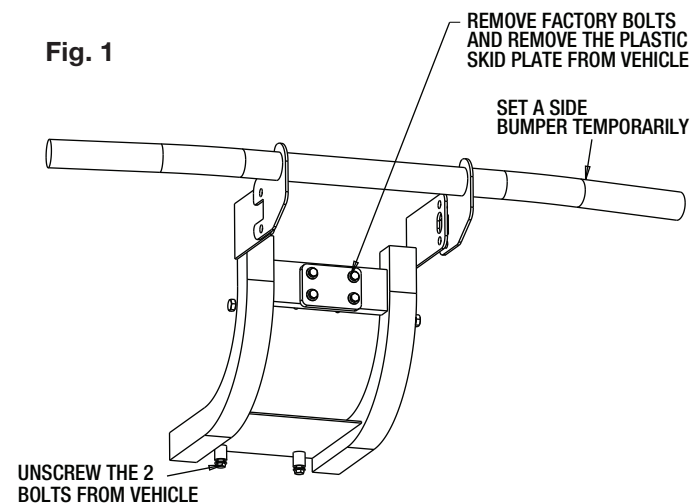

3. Position the Skid Plate (1) over the existing four holes from the vehicle. Secure the four 3/8 x3.5 bolts (8) onto the frame. See Fig 2.

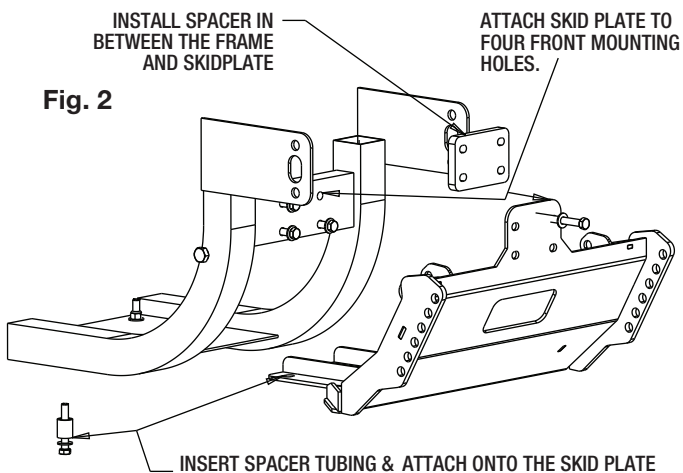

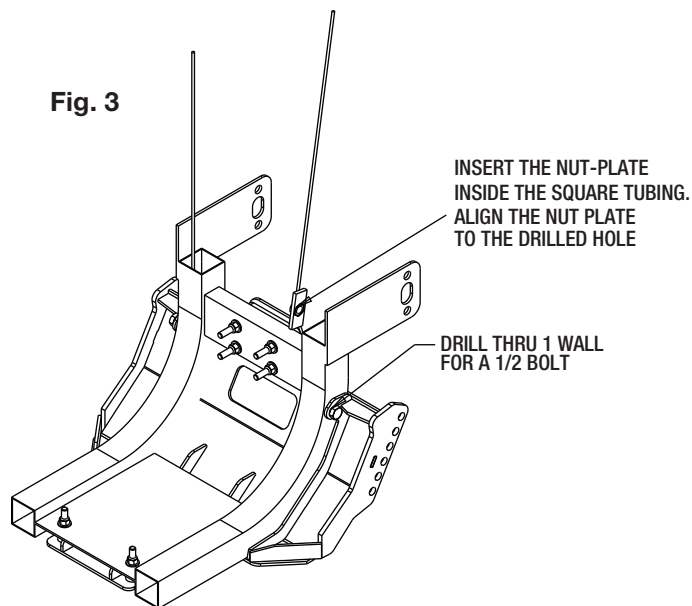

4. Insert the Spacer tubing in between the Skidplate (1) and the bottom frame. Secure it with two 3/8 x 2.5" bolts(6) & two nuts (9).
5. On the PS side, mark and drill the side holes with the 9/16 drill. Secure it with the 1/2" bolts (10) and nut plate (5). Repeat for the other side of the frame. See Fig 3.

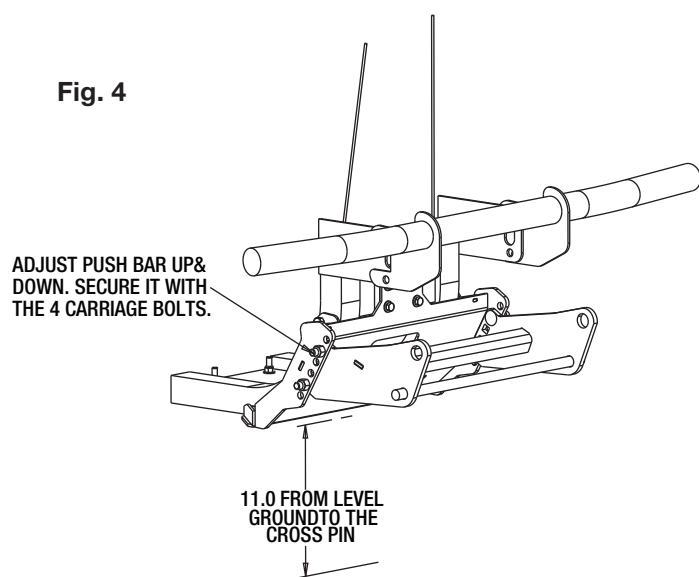

6. Connect the Pushbar (2) onto the Skid plate mounting (1) with four carriage bolts (11). Adjust them up and down to get the cross pin measuring 11 inches from the ground. Secure them with four lock nuts (12). See Fig 4.



7. Torque all fasteners as shown in the chart. Check and re-torque all fasteners after 5 hours of usage to ensure safe plow operation.

Recommended Fastener Torque Chart (ft.-lb.)			
Size	 SAE Grade 2	 SAE Grade 5	 SAE Grade 8
1/4-20	6	9	13
5/16-18	11	18	28
3/8-16	19	31	46
3/8-24	24	46	68
7/16-14	30	50	75
1/2-13	45	75	115
9/16-12	66	110	165
5/8-11	93	150	225
3/4-10	150	250	370
7/8-9	150	378	591
1-8	220	583	893

Metric Grade 8.8 (ft.-lb.)			
Size	Torque	Size	Torque
M6	7	M12	60
M8	17	M14	95
M10	35	M16	155

These torque values apply to fasteners except those noted in the instruction.

WARNING

- DO NOT under any circumstances disable, remove or relocate any sensors or components related to the operation of the air bags.
- Always follow the vehicle manufacturers' recommendations relating to snowplow installation.
- To comply with Federal Regulations and to assure a safe vehicle, the Front Gross Axle Weight Rating (FGAWR), Rear Gross Axle Weight Rating (RGAWR), and the Gross Vehicle Weight Rating (GAWR) must not be exceeded at any time.
- Due to the variety of equipment that can be installed on this vehicle, it is necessary to verify that the Front Gross Axle Weight Rating (FGAWR), Rear Gross Axle Weight Rating (RGAWR), and the Gross Vehicle Weight Rating (GAWR) are not exceeded at any time. This may require weighing the vehicle and adding ballast as necessary. It may also limit payload capacity of the vehicle. It is the operator's responsibility to verify that these ratings are not exceeded.

CAUTION

- Read all instructions prior to assembly
- It is critical that all fasteners be properly torqued for safe plow operation – see chart above.
- Fasteners should be retorqued after 5-8 hours of plow use

FULL ONE-YEAR WARRANTY

Manufacturer will repair, or at manufacturer's discretion will replace any part of this snowplow which proves to be defective in workmanship or material under normal use for a period of one year from the date of delivery to the original purchaser. Any cost incurred in returning the product to the supplier is the responsibility of the consumer.

EXCLUSIONS

Manufacturer shall not be liable for special, incidental, or consequential damages, or for damages resulting from lack of necessary maintenance, from misuse, abuse, acts of God, or alteration of the product. Some states do not allow the exclusion or limitation of incidental or consequential damages, so the above limitation or exclusion may not apply to you.