

Vibrator Adapter Service Kit

Stainless Steel Hopper Spreaders

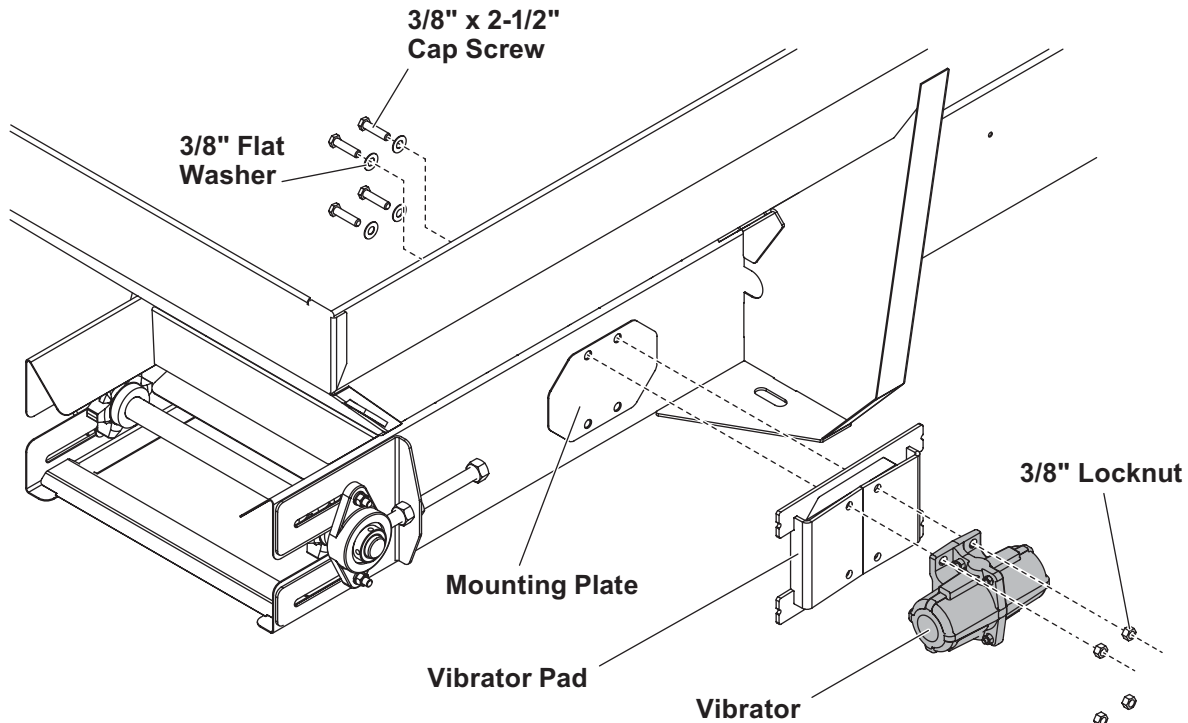

⚠ WARNING

Do not exceed GVWR or GAWR ratings as found on the driver-side vehicle door cornerpost.

⚠ CAUTION

Read this document before installing the Vibrator Adapter Service Kit.

⚠ CAUTION

Use standard methods and practices when attaching spreader and installing accessories, including proper personal protective safety equipment.

INSTALLATION INSTRUCTIONS

1. Park the vehicle on a smooth, level, hard surface, such as concrete. Turn the vehicle ignition to the "OFF" position and remove the key.
2. Remove the 4 cap screws, flat washers, and locknuts attaching the vibrator to the hopper.
3. Position the supplied vibrator pad over the mounting plate and reinstall the vibrator using the supplied 3/8" x 2-1/2" cap screws, 3/8" flat washers, and 3/8" locknuts. The cap screws with washers must be inserted from the inside, with the nuts on the outside, to avoid interference with the conveyor chain.

The company reserves the right under its product improvement policy to change construction or design details and furnish equipment when so altered without reference to illustrations or specifications used. This equipment manufacturer or the vehicle manufacturer may require or recommend optional equipment for spreaders. Do not exceed vehicle ratings with a spreader. The company offers a limited warranty for all spreaders and accessories. See separately printed page for this important information.

Printed in U.S.A.
