



Assembly & Installation Instructions

FOR
SUBFRAME COMPONENTS PACKAGE 99100071
AND
SUBFRAME NOSE PIECE PACKAGE 96100694

TO FIT
1987 & LATER DODGE DAKOTA 4X4 PICKUP



1. THINK SAFETY, ALWAYS WEAR SAFETY GLASSES WHEN PERFORMING THE OPERATIONS PRESCRIBED IN THESE INSTRUCTIONS
2. READ ALL INSTRUCTIONS CAREFULLY BEFORE ATTEMPTING INSTALLATION
3. BEFORE BEGINNING WORK MAKE SURE TO SET PARKING BRAKE AND CHOCK WHEELS

MINIMUM VEHICLE RECOMMENDATIONS

Heavy Duty Torsion Bars
AHH Snow Plow Prep Package

ASSEMBLY TOOLS NEEDED

Sockets 7/16" – 1-1/8"
Wrenches 7/16" – 1-1/8"
Torque Wrench
Hacksaw

INSTALLATION NOTES

1. Unless specified, mount all Sub-Frame components to vehicle before tightening any bolts.
2. Vehicle should be parked on a level surface with the front suspension normally loaded.

MOUNTING INSTRUCTIONS

1. Remove air dam from front of vehicle (retain with hardware for future use). Air dam can be cut to fit front crossmember.
2. Remove the vehicle differential skid plate.
3. Remove bumper and bumper mounting brackets from frame.

NOTE: It will be necessary to cut bumper mounting brackets along bottom of frame on 1991 - Present Models.

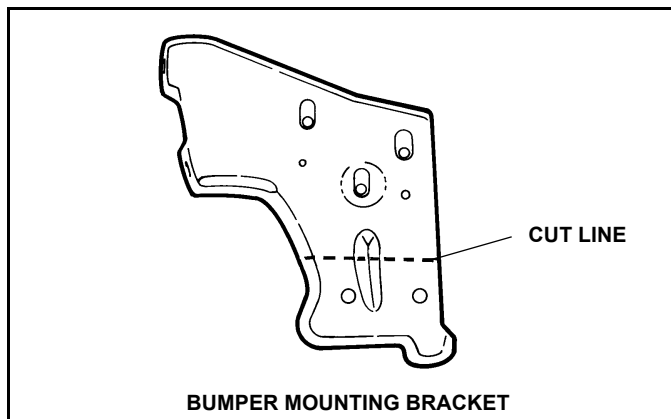

4. Remove left and right plastic control arm access attach the Front Crossmember to the vehicle frame tubes.
5. Pre-assemble LH & RH (#96101038 & #96101039) Mounting Assemblies to Front Crossmember (#96101036) using (8) eight 1/2" x 1-1/2" Cap-screws (#98009010), Flatwashers and Nylock Nuts provided. Secure loosely.

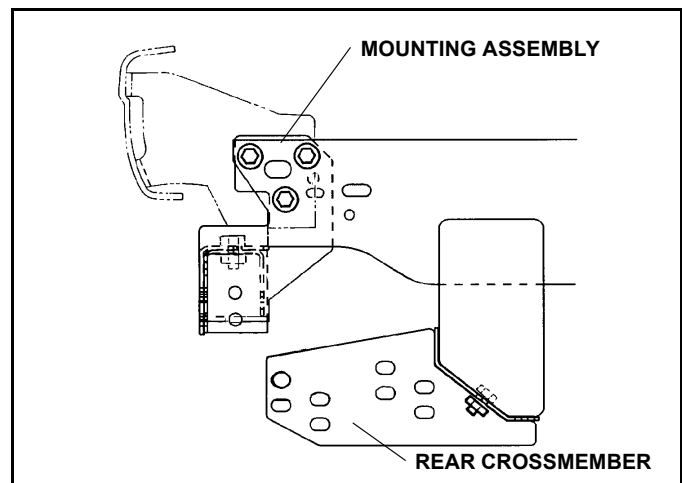

6. Insert Left & Right Handle Bolts (#96001428 & #96001429) through vehicle control arm access holes and into existing slots in vehicle front crossmember.

7. Lift and align Rear Crossmember (#96101037) with holes and Handle Bolts from step #6. Secure loosely using Nylock Nuts (#98009038) and Flatwashers provided.

8. Install assembly from step #5 to inside of vehicle frame rails, sandwiched between frame and bumper brackets. Align 3 of the 4 holes with existing slots in vehicle frame. Replace bumper brackets and secure using 7/16" x 1-1/2" Capscrews (#98009048) Flatwashers and Nylock Nuts provided.

9. Raise Sub-Frame Assembly (#96100294) and align mounting holes with holes in front crossmember. Secure using 5/8" x 1-1/2" Capscrews, Flatwashers and Nylock Nuts Provided. Level Sub-Frame, aligning rear mount holes with slots in Rear Crossmember. Secure using two (2) 5/8" x 3-1/2" (#98009042), two (2) 5/8" x 1-1/2" Capscrews (#98009115), Flatwashers and Nylock Nuts provided.

10. Using the Torque Specification Chart below, torque all Capscrews, start at the rear and work forward.

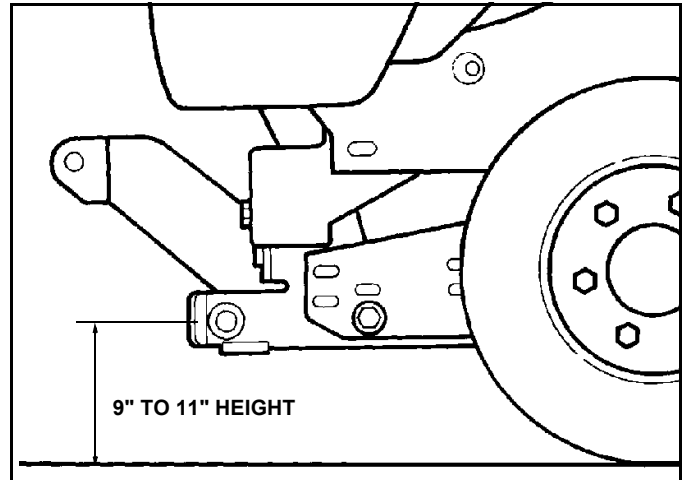

IMPORTANT: height from the center of the lower Plow Mounting holes on the Sub-Frame to the ground should be between 9" and 11" to insure proper operation.

REMEMBER After 5 to 10 hours of snowplow usage, re-torque all capscrews!

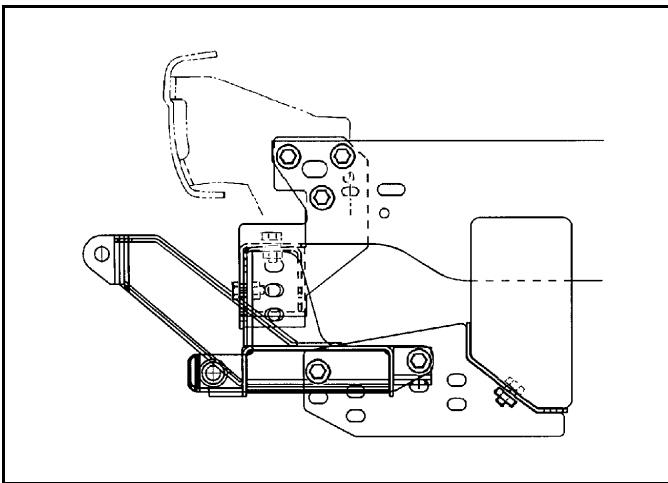

TORQUE SPECIFICATIONS FOR STANDARD MACHINE HARDWARE

Bolt Size	GR.2 Dry	GR.5 Dry	GR.8 Dry	Metric Size	GR.8.8 Dry
1/4"	66*	9	12	M8	17
5/16"	11	17	25	M10	35
3/8"	20	30	45	M12	60
7/16"	32	50	70	M14	95
1/2"	50	75	110	M16	155
9/16"	70	110	150		
5/8"	100	150	220		
3/4"	175	260	380		
7/8"	170	430	600		
1"	250	640	900		

Note: These torque values are to be used for all hardware. Unless otherwise specified, all torque values must meet this specification.
 Note: All torque values are in Ft.-Lbs unless otherwise stated
 Note: *In-Lbs

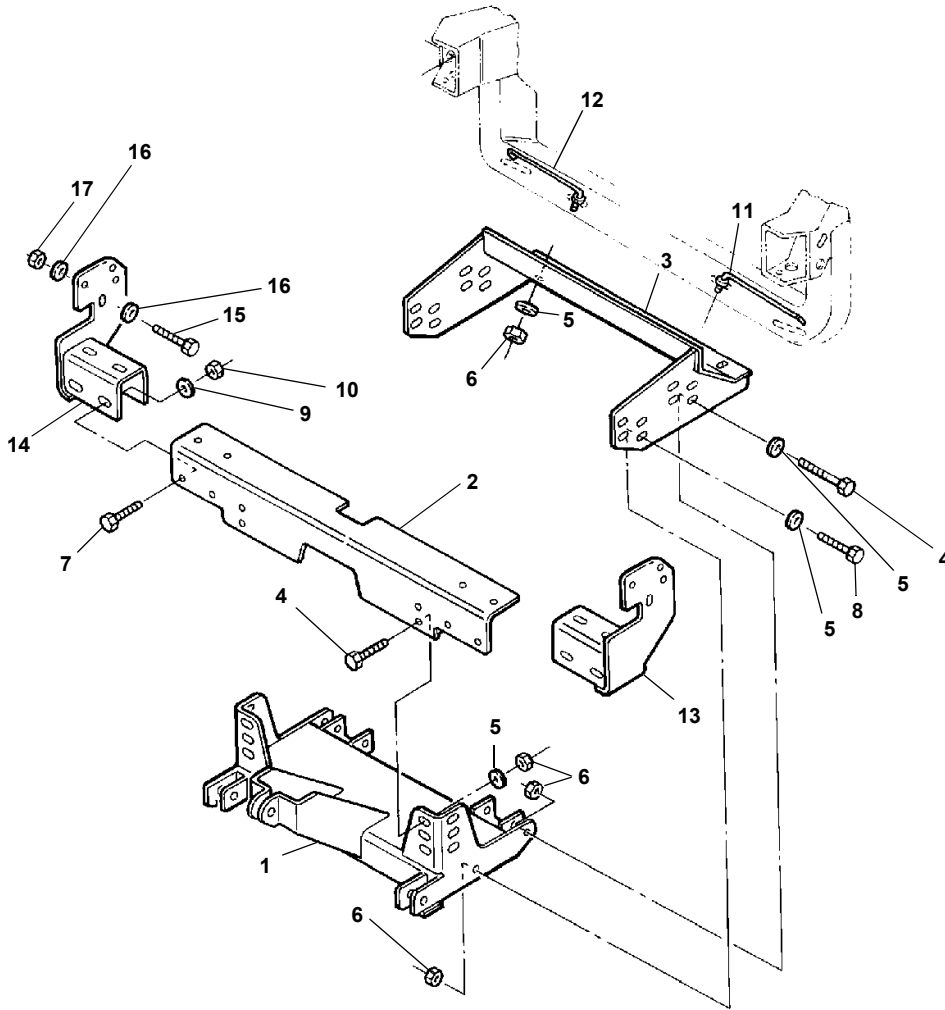

ITEM	PART NO.	DESCRIPTION	QTY.
1	96100694	Sub-Frame , Nose Piece (96100294).....	1
2	96101036	Crossmember, Front.....	1
3	96101037	Crossmember, Rear	1
4	98009115	Capscrew, Hex Head, 5/8"-11NC x 1-1/2".....	6
5	98009039	Washer, Flat, 5/8"	10
6	98009038	Nut, Hex, 5/8"-11NC Nylock	10
7	98009010	Capscrew, Hex Head, 1/2"-13NC x 1-1/2".....	8
8	98009042	Capscrew, Hex Head, 5/8"-11NC x 3-1/2".....	2
9	98009011	Washer, Flat, 1/2"	8
10	98009013	Nut, Hex, 1/2"-13 NC Nylock	8
11	96001428	Bolt, Handle, LH	1
12	96001429	Bolt, Handle, RH.....	1
13	96101038	Mounting Assembly, LH.....	1
14	96101039	Mounting Assembly, RH	1
15	98009048	Capscrew, Hex Head, 7/16"-14NC x 1-1/2".....	6
16	98009049	Washer, Flat, 7/16".....	12
17	98009050	Nut, Hex, 7/16"-14 NC Nylock	6



SNO-WAY INTERNATIONAL, INC.