

# **SNO-WAY<sup>®</sup>**

**SNOW & ICE CONTROL EQUIPMENT**

## **Assembly & Installation Instructions**

**FOR  
SUBFRAME COMPONENTS PACKAGE 99100408  
AND  
SUBFRAME NOSE PIECE PACKAGE 96103001**

**TO FIT  
1998 - LATER NISSAN FRONTIER 4x4**



1. **THINK SAFETY, ALWAYS WEAR SAFETY GLASSES WHEN PERFORMING THE OPERATIONS PRESCRIBED IN THESE INSTRUCTIONS**
2. **READ ALL INSTRUCTIONS CAREFULLY BEFORE ATTEMPTING INSTALLATION**
3. **BEFORE BEGINNING WORK MAKE SURE TO SET PARKING BRAKE AND CHOCK WHEELS**



### MINIMUM VEHICLE RECOMMENDATIONS

Heavy Duty Alternator                      Heavy Duty Battery  
 Manufacturers Snow Plow Package

*NOTE: On some vehicles it may be necessary to use a form of load booster to decrease the vehicle's front suspension sag with the snow plow in place. This can be accomplished with the use of supplementary air bags, booster springs, or similar load boosting devices. Since there are different load boosting devices available, it will up to the customer/end user to decide and purchase the product to suit the application, and not the responsibility of Sno-Way International, Inc.*

### ASSEMBLY TOOLS NEEDED

Impact Sockets	7/16" – 1-3/8"
Impact Sockets Metric	10mm – 19mm
Wrenches	7/16" – 1-3/8"
Wrenches Metric	10mm – 19mm
Torque Wrench	
Rat Tail Pry Bar	

### INSTALLATION NOTES

1. **Unless otherwise specified, mount all Subframe components to vehicle before tightening any hardware.**
2. **It is recommended that LOCTITE®, or similar thread locking product, be used on ALL mounting hardware (i.e. Nuts, Cap Screws, Bolts, etc.).**
3. Vehicle should be parked on a level surface with a normal vehicle load on the FRONT suspension.
4. Items in parentheses ( ) refer to quantity required for this step. Items in parentheses with a pound sign (#) indicate the part number as found in the parts list on the last page of this document.  
 Example: (2) 5/8" x 1-1/2" Cap Screws (#6).
5. It maybe necessary to relocate license plate holder. Relocate under the driver's side headlight by drilling new holes in the bumper.

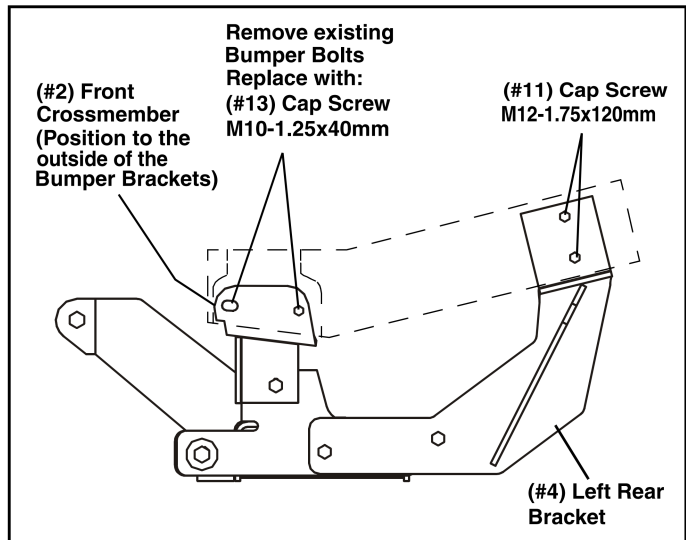

*NOTE: Typically, the bumper is attached to the vehicle in six places. When the four bolts securing the bumper brackets to the vehicle frame are removed, the remaining two fasteners should secure the bumper in place until the Front Crossmember (#2) is installed.*

### MOUNTING INSTRUCTIONS

1. Remove splash shield from the underside of the vehicle. Retain with hardware for future use.
2. Install Right (#3) and Left (#4) Rear Brackets: Remove and discard the two rear bolts on the gearbox assemblies located on the frame rails. Position the Rear Bracket upper flanges at the inside of the each frame rail and align the two holes in each flange with existing holes in the frame. Secure using (4) M12-1.75 x 120mm Cap Screws (#11), (4) M12-1.75 Flat Washers (#9) and (4) M12 Nylock Nuts (#10).
3. Remove and discard the four bolts attaching the bumper brackets to the vehicle frame.
4. Position the Front Crossmember (#2) to the outside of the bumper brackets. Place a Spacer (#12) at each side between the bumper brackets and Front Crossmember flanges, align and secure with (4) M10-1.25x40mm Cap Screws (#13).
5. Attach the Nosepiece Subframe Assembly (#1) to the Front Crossmember (#2) and secure using (4) 5/8" x 1 1/2" Cap Screws (#5), (4) Flat Washers (#8) and Nylock Nuts (#7).

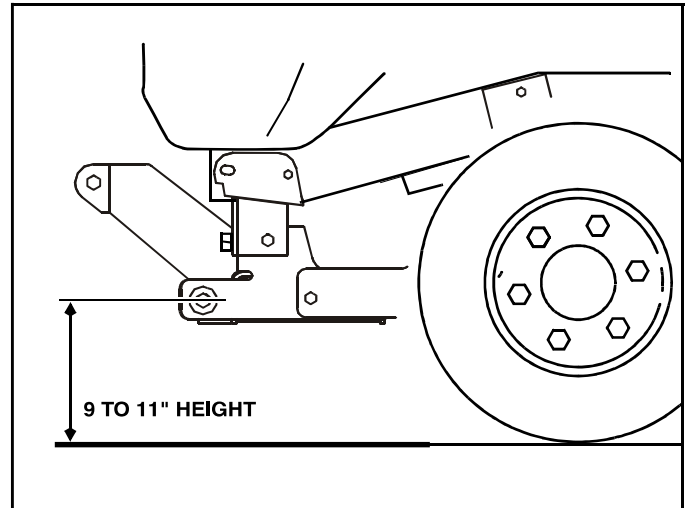
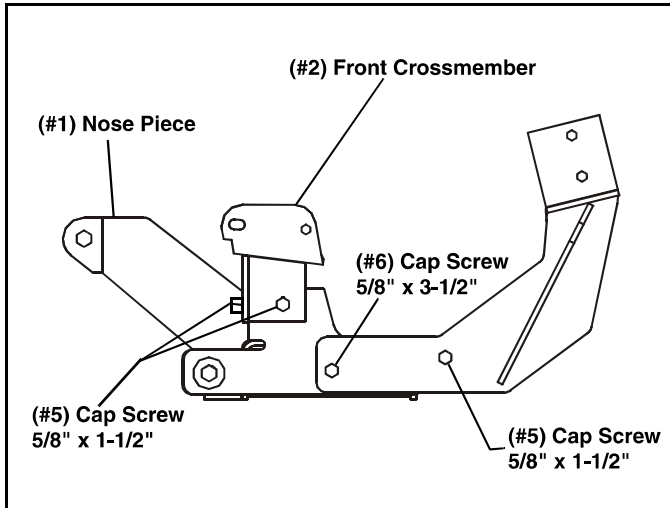

- Attach the Nose Piece Subframe Assembly (#1) to the Rear Mounting Brackets (#3) and (#4) with (2) 5/8 x 3-1/2" Cap Screws (#6) in the front holes and (2) 5/8" x 1-1/2" Cap Screws (#5) in the rear holes. Secure using (4) Nylock Nuts (#7).
- Using the Torque Specification Chart provided, first torque the Nose Piece (#1) to the Front Crossmember (#2). Start by torquing the two front Cap Screws (#5) and then the two side Cap Screws (#5). Then torque the remaining Cap Screws starting at the rear and working forward.

**IMPORTANT:** Height from the center of the lower Plow mounting holes on the Subframe to the ground should be between 9" and 11" to insure proper operation.

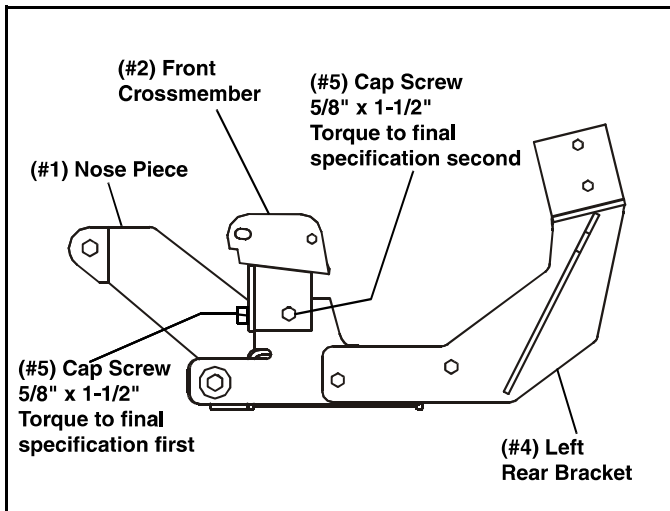

TORQUE SPECIFICATIONS FOR STANDARD MACHINE HARDWARE					
Bolt Size	GR.2 Dry	GR.5 Dry	GR.8 Dry	Metric Size	GR.8.8 Dry
1/4"	66*	9	12	M8	17
5/16"	11	17	25	M10	35
3/8"	20	30	45	M12	60
7/16"	32	50	70	M14	95
1/2"	50	75	110	M16	155
9/16"	70	110	150		
5/8"	100	150	220		
3/4"	175	260	380		
7/8"	170	430	600		
1"	250	640	900		

Note: These torque values are to be used for all hardware. Unless otherwise specified, all torque values must meet this specification.  
 Note: All torque values are in Ft.-Lbs unless otherwise stated  
 Note: \*In-Lbs

**REMEMBER** After 5 to 10 hours of snowplow usage, re-torque all Cap Screws!

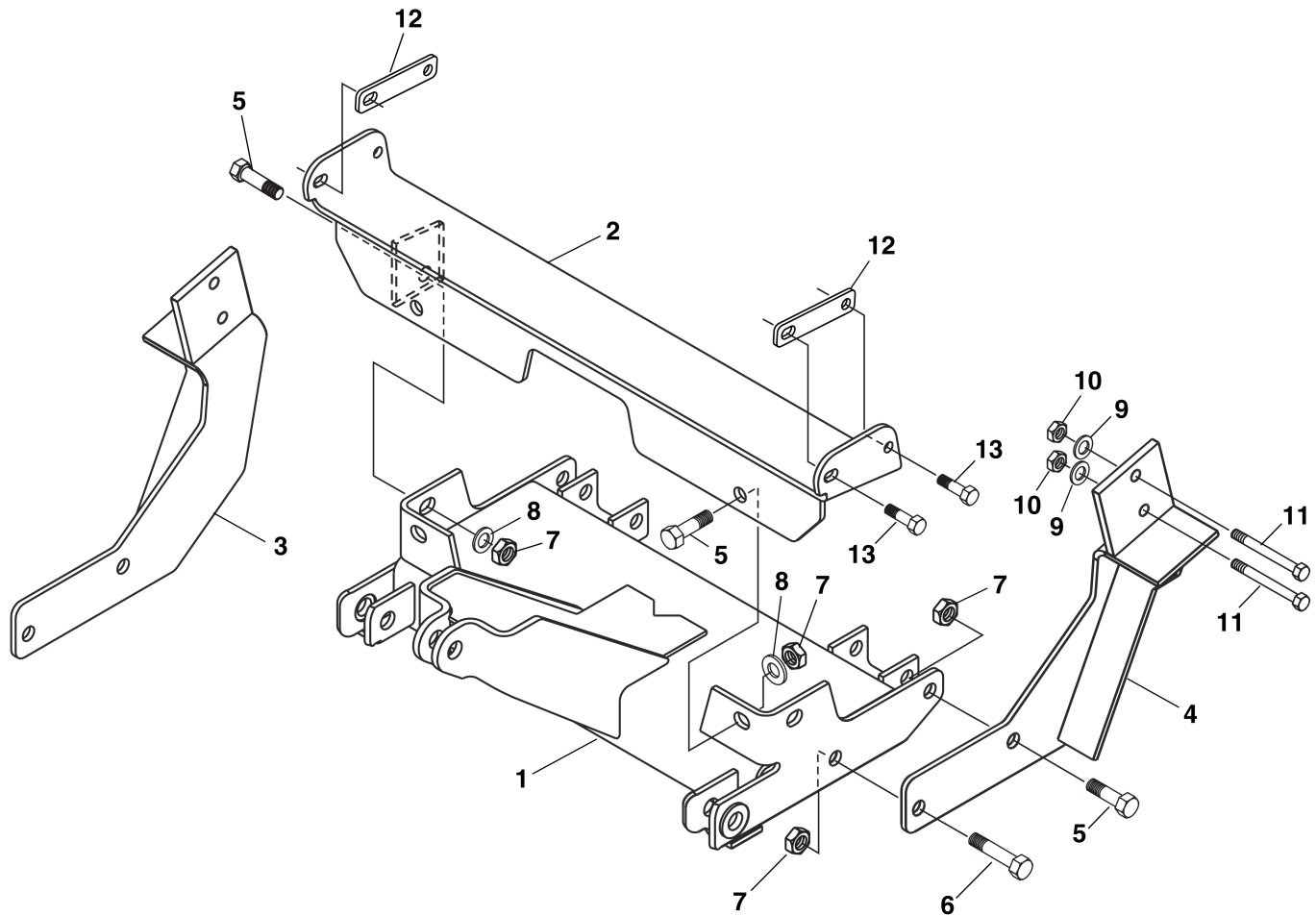

Note: It is recommended that LOCTITE®, or similar thread locking product, be used on ALL mounting hardware (i.e. Nuts, Cap Screws, Bolts, etc.).

ITEM	PART NO.	DESCRIPTION	QTY.
1	96103001	Subframe, Nose Piece (96102924)	1
2	96103876	Front Crossmember	1
3	96104930	Bracket, Rear, Right	1
4	96104929	Bracket, Rear, Left	1
5	98009115	Cap Screw, Hex Head, 5/8"-11 x 1-1/2"	6
6	98009042	Cap Screw, Hex Head, 5/8"-11 x 3-1/2"	2
7	98009038	Nut, Hex, Nylock 5/8"-11	8
8	98009039	Washer, Flat 5/8" (Regular)	4
9	98100049	Washer, Flat M12-1.75	4
10	98100250	Nut, Hex Head, M12-1.75	4
11	98100249	Cap Screw, Hex Head, M12-1.75 x 120mm	4
12	96107962	Spacer	2
13	98100046	Cap Screw, Hex Head, M10-1.25 x 40mm	4

SNO-WAY® INTERNATIONAL, INC.



Hartford, WI 53027 USA  
 Website: [www.snoway.com](http://www.snoway.com)  
 ©2005 Sno-Way® International