



**Assembly
&
Installation Instructions**

**FOR
SUBFRAME COMPONENTS PACKAGE 99100409
AND
SUBFRAME NOSE PIECE PACKAGE 96103001**

**TO FIT
2000 - TOYOTA TUNDRA PICKUP**



1. **THINK SAFETY, ALWAYS WEAR SAFETY GLASSES WHEN PERFORMING THE OPERATIONS PRESCRIBED IN THESE INSTRUCTIONS**
2. **READ ALL INSTRUCTIONS CAREFULLY BEFORE ATTEMPTING INSTALLATION**
3. **BEFORE BEGINNING WORK MAKE SURE TO SET PARKING BRAKE AND CHOCK WHEELS**



MINIMUM VEHICLE RECOMMENDATIONS

Heavy Duty Alternator Heavy Duty Battery
Manufacturers Snow Plow Package

NOTE: On some vehicles it may be necessary to use a form of load booster to decrease the vehicle's front suspension sag with the snow plow in place. This can be accomplished with the use of supplementary air bags, booster springs, or similar load boosting devices. Since there are different load boosting devices available, it will up to the customer/end user to decide and purchase the product to suit the application, and not the responsibility of Sno-Way International, Inc.

ASSEMBLY TOOLS NEEDED

Drill Bits	1/4", 17/32"
Impact Sockets	7/16" – 1-3/8"
Impact Sockets Metric	10mm – 19mm
Wrenches	7/16" – 1-3/8"
Wrenches Metric	10mm – 19mm
Torque Wrench	
Center Punch and Hammer	

INSTALLATION NOTES

1. Unless otherwise specified, mount all Sub-Frame Components to vehicle before tightening any hardware.
2. It is recommended that **LOCTITE®**, or similar thread locking product, be used on **ALL** mounting hardware (i.e. Nuts, Cap Screws, Bolts, etc.).
3. Vehicle should be parked on a level surface with a normal vehicle load on the FRONT suspension.
4. Items in parentheses () refer to quantity required for this step. Items in parentheses with a pound sign (#) indicate the part number as found in the parts list on the last page of this document. Example: (2) 5/8" x 1-1/2" Cap Screws (#7).
5. It maybe necessary to relocate license plate holder. Relocate under the driver's side headlight by drilling new holes in the bumper.

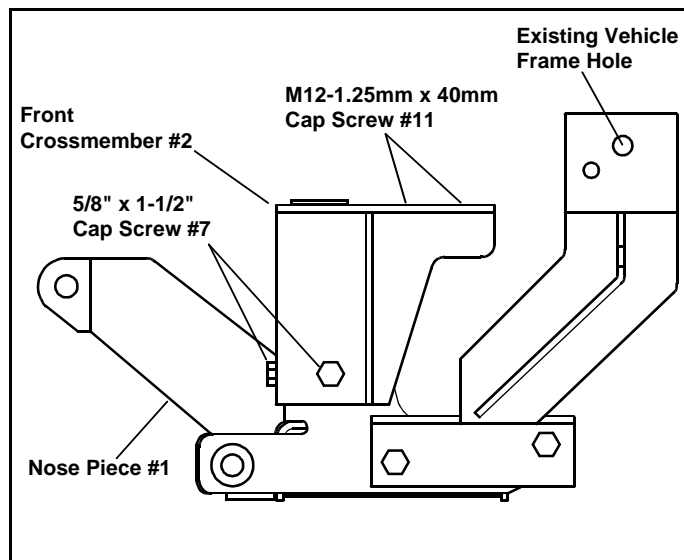

MOUNTING INSTRUCTIONS

1. Remove splash guard and tow hook(s) if equipped. Retain, with mounting hardware, for future use if plow Sub-Frame is removed.
2. Install the Front Crossmember (#2) by aligning the back holes with the existing vehicle frame tow hook holes and secure using (4) M12-1.25mm x 40mm Cap Screws (#11).

3. Using the front hole on the Front Crossmember (#2) as a template, drill a 1/4" pilot hole then a 17/32" hole through the bottom of the vehicle frame. Install (2) 1/2" x 1-1/2" Cap Screws (#15), Flat Washer (#16), and Nut Plates (#6).
4. Install the Rear Crossmember (#3) by aligning the back holes with the existing vehicle frame hole located on the side of the vehicle frame. Using the other hole as a template, drill a 1/4" pilot hole then drill a 17/32" hole all the way through the vehicle frame. Insert the Tube Spacer (#4) through the frame, place Backing Plate (#5) against the inside of the frame, insert (1) 5/8" x 5" Cap Screw (#12) from the engine side through all and secure with (1) 5/8" Nylock Nut (#9). Repeat for the other side. From the outside of the vehicle frame, insert (1) 1/2" x 5" Cap Screw (#13) and secure with 1/2" Nylock Nut (#14). Repeat for the other side.
5. Attach the Nose Piece Sub-Frame Assembly (#1) to the Front Crossmember (#2) and secure using (4) 5/8" x 1-1/2" Cap Screws (#7), 5/8" Flat Washers (#8), and 5/8" Nylock Nuts (#9).



WARNING

Beware of brake and fuel lines secured to inside wall of frame rails when drilling holes in vehicle frame!

FAILURE TO HEED CAN RESULT IN SERIOUS INJURY OR DEATH!

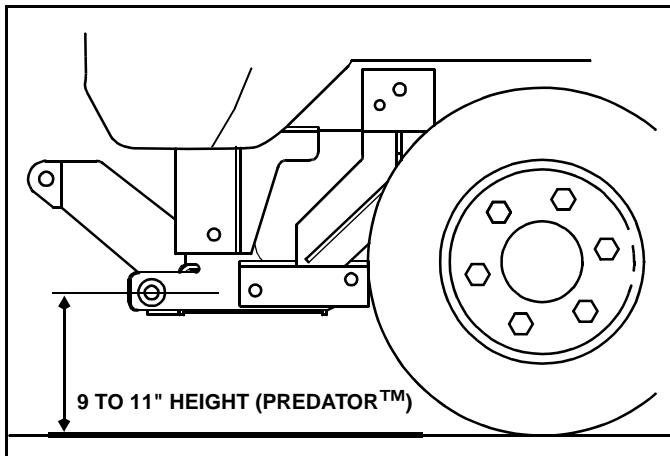

IMPORTANT: Height from the center of the lower Plow Mounting holes on the Sub-Frame to the ground should be between 9" and 11" to insure proper operation.



WARNING

Beware of brake and fuel lines secured to inside wall of frame rails when drilling holes in vehicle frame!

FAILURE TO HEED CAN RESULT IN SERIOUS INJURY OR DEATH!

6. Attach the Nose Piece Sub-Frame Assembly (#1) to the Rear Crossmember (#3). From the outside, place (2) 5/8" x 3-1/2" Cap Screws (#10) in the front holes, and (2) 5/8" x 1-1/2" Cap Screws (#7) in the rear holes. Secure using (4) 5/8" Nylock Nut (#9).

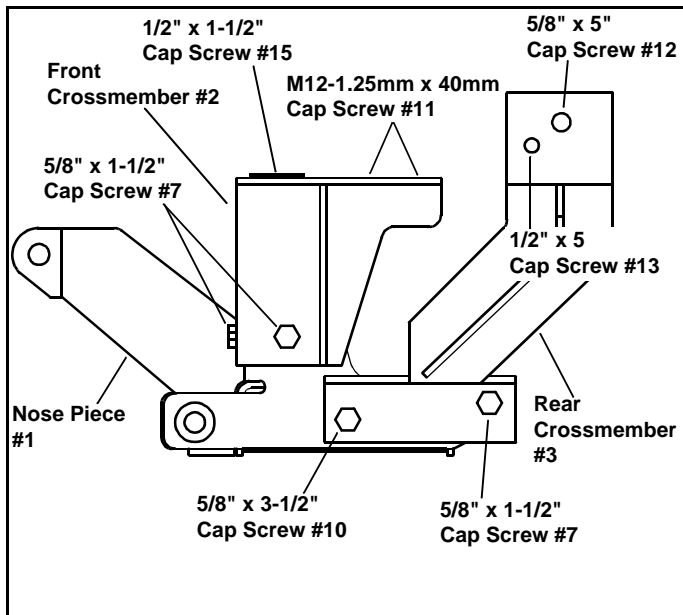

7. Using the Torque Specification Chart provided, first torque the Nose Piece (#1) to the Front Crossmember (#2). Start by torquing the two Cap Screws (#7) and then the two side Cap Screws (#7). Then torque the remaining Cap Screws **starting at the rear** and working forward.

TORQUE SPECIFICATIONS FOR STANDARD MACHINE HARDWARE

Bolt Size	GR.2 Dry	GR.5 Dry	GR.8 Dry	Metric Size	GR.8.8 Dry
1/4"	66*	9	12	M8	17
5/16"	11	17	25	M10	35
3/8"	20	30	45	M12	60
7/16"	32	50	70	M14	95
1/2"	50	75	110	M16	155
9/16"	70	110	150		
5/8"	100	150	220		
3/4"	175	260	380		
7/8"	170	430	600		
1"	250	640	900		

Note: These torque values are to be used for all hardware. Unless otherwise specified, all torque values must meet this specification.

Note: All torque values are in Ft.-Lbs unless otherwise stated

Note: *In-Lbs

REMEMBER After 5 to 10 hours of snowplow usage, re-torque all Cap Screws!

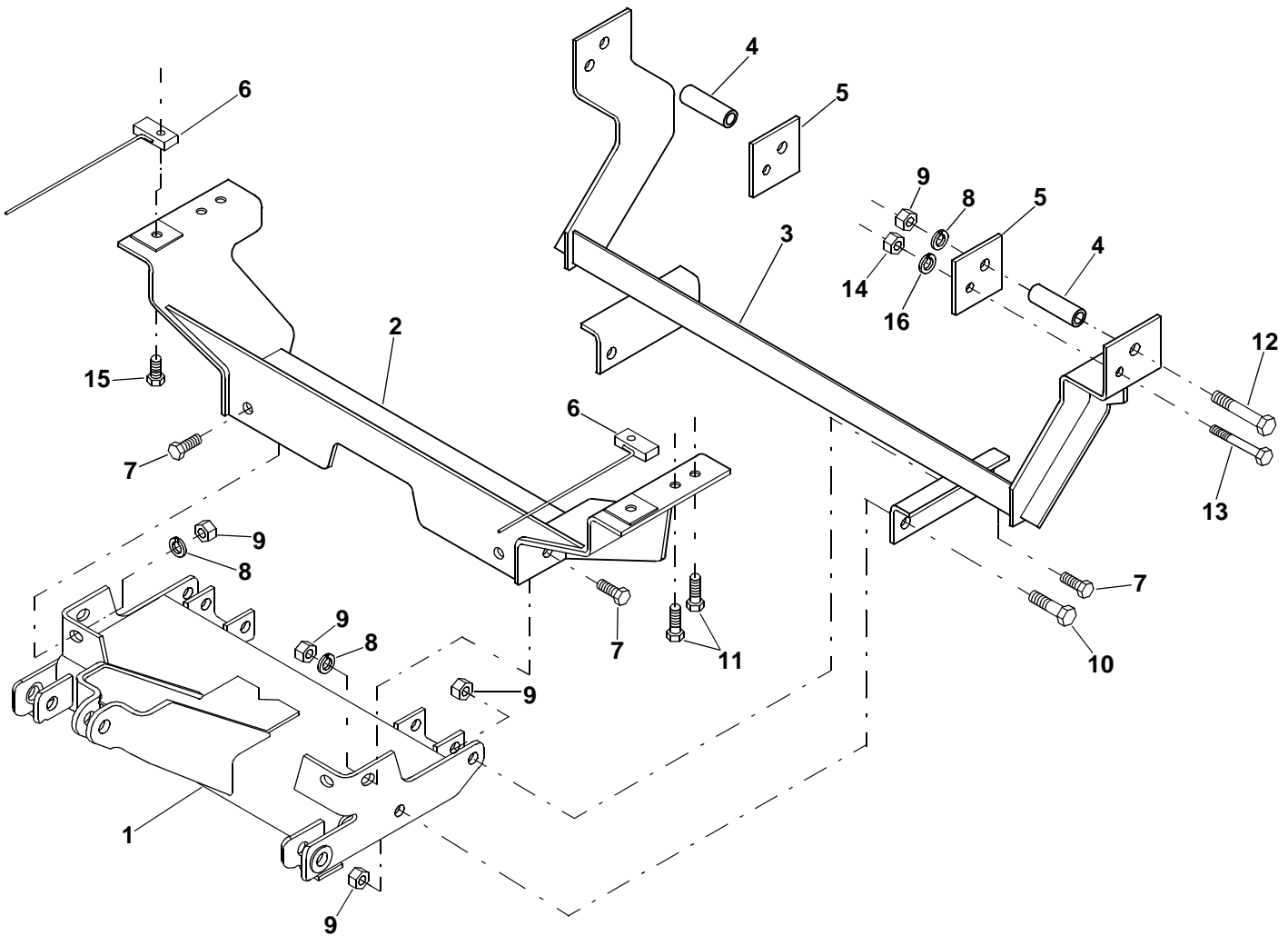

Note: It is recommended that LOCTITE®, or similar thread locking product, be used on ALL mounting hardware (i.e. Nuts, Cap Screws, Bolts, etc.).

ITEM	PART NO.	DESCRIPTION	QTY.
1	96103001	Sub-Frame, Nose Piece (96102924)	1
2	96104088	Front Crossmember	1
3	96104095	Rear Crossmember	1
4	96104099	Spacer, Tube	2
5	96104107	Backing Plate	2
6	96104171	Assembly, Nut Plate	2
7	98009115	Cap Screw, Hex Head 5/8"-11 UNC x 1-1/2"	6
8	98009039	Washer, Flat 5/8"	8
9	98009038	Nut, Hex, Nylock 5/8"-11 NC	10
10	98009042	Cap Screw, Hex Head 5/8"-11 UNC x 3-1/2"	2
11	98009054	Cap Screw, Hex Head M12-1.25mm x 40mm	4
12	98009196	Cap Screw, Hex Head 5/8"-11 UNC x 5"	2
13	98009043	Cap Screw, Hex Head 1/2"-13 UNC x 5"	2
14	98009013	Nut, Hex, Nylock 1/2"-13 NC	2
15	98009010	Cap Screw, Hex Head 1/2"-13 UNC x 1-1/2"	2
16	98009011	Washer, Flat 1/2"	2

SNO-WAY® INTERNATIONAL, INC.



©1999 Sno-Way® International