



Assembly & Installation Instructions

**FOR
SUBFRAME COMPONENTS PACKAGE 99100415
AND
SUBFRAME NOSE PIECE PACKAGE 96103001**

**TO FIT
2000 & LATER DODGE DAKOTA PICKUP 4X4
2000 & LATER DODGE DURANGO 4X4**



1. **THINK SAFETY, ALWAYS WEAR SAFETY GLASSES WHEN PERFORMING THE OPERATIONS PRESCRIBED IN THESE INSTRUCTIONS**
2. **READ ALL INSTRUCTIONS CAREFULLY BEFORE ATTEMPTING INSTALLATION**
3. **BEFORE BEGINNING WORK MAKE SURE TO SET PARKING BRAKE AND CHOCK WHEELS**



MINIMUM VEHICLE RECOMMENDATIONS

Heavy Duty Alternator Heavy Duty Battery

NOTE: On some vehicles it may be necessary to use a form of load booster to decrease the vehicle's front suspension sag with the snow plow in place. This can be accomplished with the use of supplementary air bags, booster springs, or similar load boosting devices. Since there are different load boosting devices available, it will up to the customer/end user to decide and purchase the product to suit the application, and not the responsibility of Sno-Way International, Inc.

ASSEMBLY TOOLS NEEDED

| | |
|-----------------|----------------|
| Impact Sockets | 7/16" – 1-3/8" |
| Metric Sockets | 10 – 19 mm |
| Wrenches | 7/16" – 1-3/8" |
| Metric Wrenches | 10 – 19 mm |
| Torque Wrench | |

INSTALLATION NOTES

1. **Unless otherwise specified, mount all Sub-Frame Components to vehicle before tightening any hardware.**
2. **It is recommended that LOCTITE®, or similar thread locking product, be used on ALL mounting hardware (i.e. Nuts, Cap Screws, Bolts, etc.).**
3. Vehicle should be parked on a level surface with a normal vehicle load on the FRONT suspension.
4. Items in parentheses () refer to quantity required for this step. Items in parentheses with a pound sign (#) indicate the part number as found in the parts list on the last page of this document.
Example: (2) 5/8" x 1-1/2" Cap Screws (#7).
5. It may be necessary to relocate license plate holder. Check state and local laws for placement, if needed.

MOUNTING INSTRUCTIONS

1. If vehicle is equipped with bumper lamps, disconnect light harness so that bumper can be removed.
2. Remove four bumper bolts from the top of bumper brackets located under the vehicle hood. Remove remaining bumper bracket bolts on side of vehicle frame. Remove bumper and retain hardware for reinstallation in later step.
3. Remove snap fasteners and air deflector.
4. Remove the six metric nuts on the metric bolts located inside the box frame horn on either side of the vehicle. Retain two metric nuts for reinstallation and save the other metric nuts in the event the subframe is removed from the vehicle.

NOTE: Only the four M12 serrated button head screws at the front of the frame horns need to be driven out. The screws near the back of the radiator can remain in place.

5. Clamp the bumper brackets to the frame and drive out the front four metric bolts from both sides. Remove the clamp and retain the bolts in the event the subframe is removed from the vehicle.

6. Raise the Front Crossmember (#2) and slide the brackets inside the box frame horns. The slots on the brackets slide over the existing serrated button head bolts at the rear of the box frame horns.

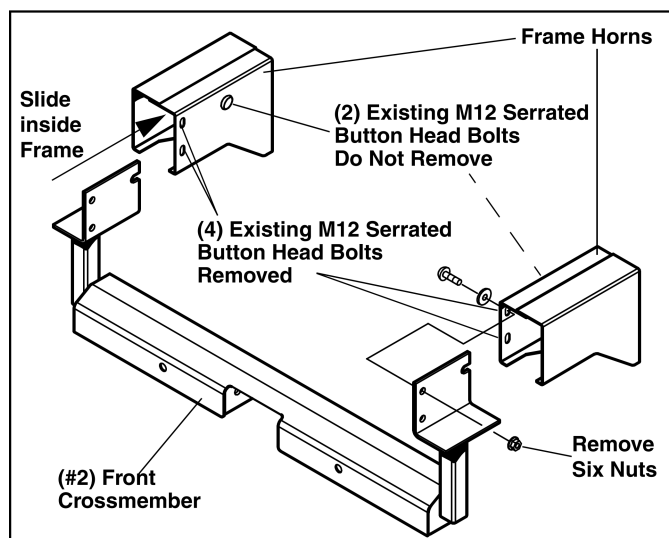

7. Align the holes in the Front Crossmember brackets with the holes of the vehicle box frame horn which the serrated button head bolts were driven out of.
8. Secure the Front Crossmember in place in the following manner. Apply a thread locking product, such as Loctite, to the threads of the two serrated button head bolts that were left in place and fasten with the removed nuts from Step #4. From the engine side of the vehicle box frame insert (4) 7/16" x 1-1/2" Cap Screws (#9) with (4) 7/16" Lock Washers (#11) into the inside of the frame. Secure using (4) 7/16" Nylock Nuts (#10) with 7/16" Lock Washers (#11).
9. Remove the plastic hole covers from each side of the vehicle frame crossmember to provide access for installing the Nut Plate Assemblies (#4).
10. Place the Rear Crossmember Assembly (#3) in position against the vehicle frame crossmember. Insert (2) 5/8" x 2" Cap Screws (#12) with (2) 5/8"

Lock Washers (#13) through the holes on the slanted surface of the vehicle crossmember and align with the (2) Nut Plate Assemblies (#4) inside the vehicle frame. Secure the top holes using (2) 1/2" x 1-1/2" Cap Screws (#14), (2) 1/2" Flat Washers (#16), and (2) 1/2" Nylock Nuts (#15).

- Place the Nosepiece (#1) in position and secure to Subframe Front Crossmember with (4) 5/8" x 1-1/2" Cap Screws (#7) and (4) 5/8" Washers (#6) and (4) 5/8" Nylock Nuts (#5). Secure Nosepiece to Rear Crossmember Assembly (#3) with (2) 5/8" x 1-1/2" Cap Screws (#7), (2) 5/8" x 3-1/2" Cap Screws (#8), and (4) 5/8" Nylock Nuts (#5).

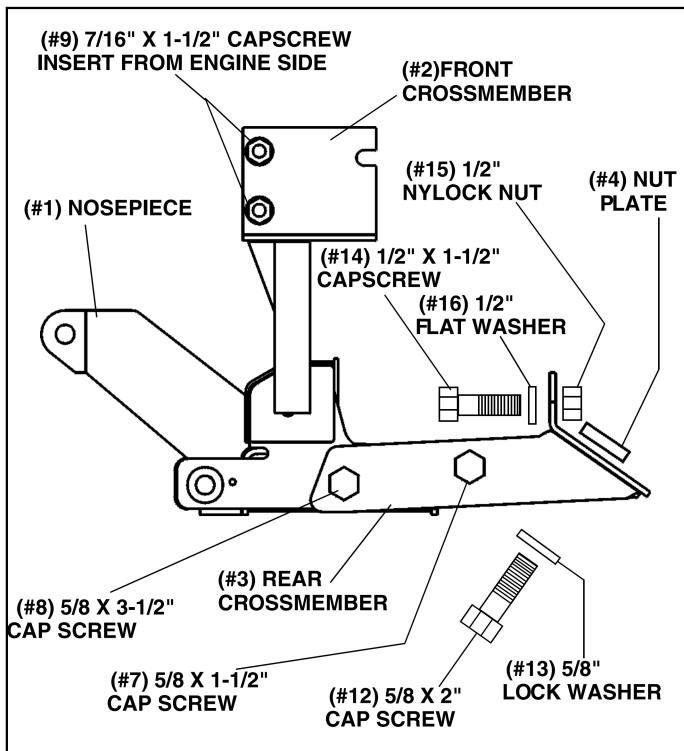

IMPORTANT: Height from the center of the lower Plow Mounting holes on the Sub-Frame to the ground should be between 9" and 11" to insure proper operation.

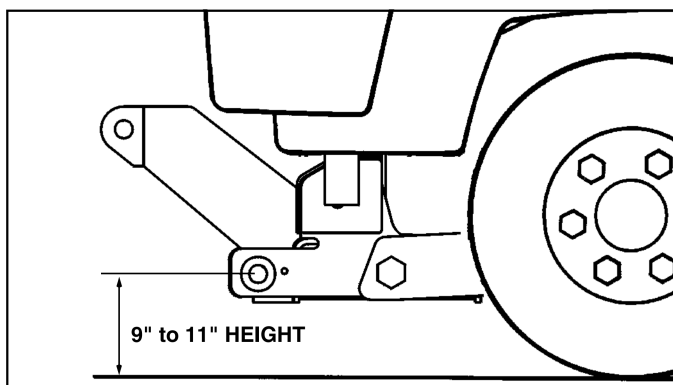

- Using the torque specification chart given, torque all bolts starting at the rear and working forward, torque all hardware (i.e.: nuts, bolts, etc.).

TORQUE SPECIFICATIONS FOR STANDARD MACHINE HARDWARE

| Bolt Size | GR.2 Dry | GR.5 Dry | GR.8 Dry | Metric Size | GR.8.8 Dry |
|-----------|----------|----------|----------|-------------|------------|
| 1/4" | 66* | 9 | 12 | M8 | 17 |
| 5/16" | 11 | 17 | 25 | M10 | 35 |
| 3/8" | 20 | 30 | 45 | M12 | 60 |
| 7/16" | 32 | 50 | 70 | M14 | 95 |
| 1/2" | 50 | 75 | 110 | M16 | 155 |
| 9/16" | 70 | 110 | 150 | | |
| 5/8" | 100 | 150 | 220 | | |
| 3/4" | 175 | 260 | 380 | | |
| 7/8" | 170 | 430 | 600 | | |
| 1" | 250 | 640 | 900 | | |

Note: These torque values are to be used for all hardware. Unless otherwise specified, all torque values must meet this specification.
 Note: All torque values are in Ft.-Lbs unless otherwise stated
 Note: *In-Lbs

REMEMBER After 5 to 10 hours of snowplow usage, re-torque all Cap Screws!

- Reinstall Front Bumper on to vehicle. Reinstall driving light harness plugs if so equipped.

NOTE: Front air dam can be modified to clear Sub-Frame by cutting dam to allow clearance for nose of Sub-Frame. Cut air dam as shown and remove cut section or fold back for when nose piece is removed.

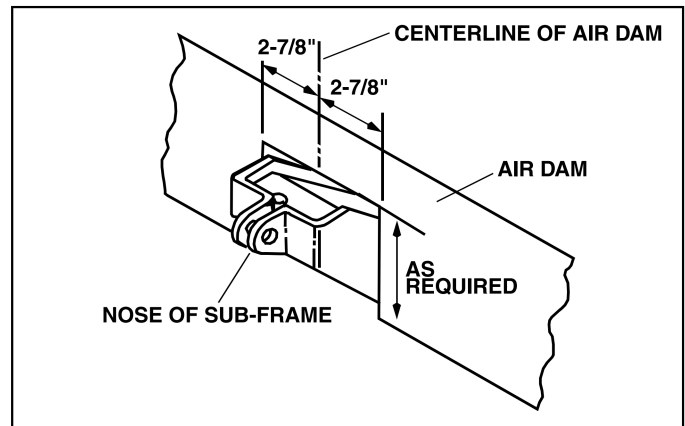

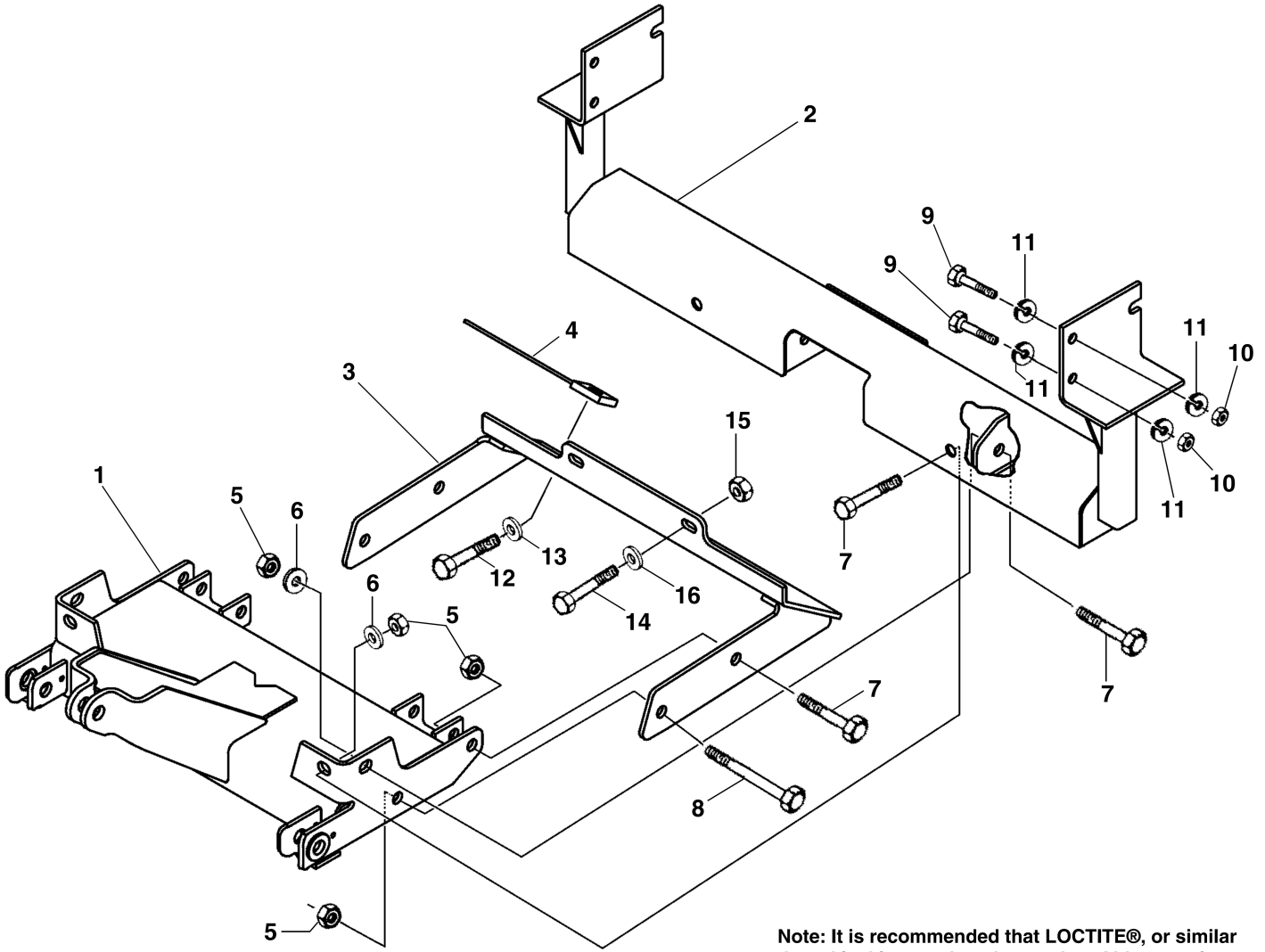

Note: It is recommended that LOCTITE®, or similar thread locking product, be used on ALL mounting hardware (i.e. Nuts, Cap Screws, Bolts, etc.).

| ITEM | PART NO. | DESCRIPTION | QTY. |
|------|----------|--|------|
| 1 | 96103001 | Sub-Frame, Nosepiece (96102924) | 1 |
| 2 | 96103124 | Crossmember, Front..... | 1 |
| 3 | 96105322 | Assembly, Rear Crossmember | 1 |
| 4 | 96103557 | Assembly, Nut Plate, 5/8" - 11 | 2 |
| 5 | 98009038 | Nut, Hex, Nylock, 5/8"-11 | 8 |
| 6 | 98009039 | Washer, Flat, 5/8" | 4 |
| 7 | 98009115 | Cap Screw, Hex Head, 5/8"-11 x 1-1/2" | 6 |
| 8 | 98009042 | Cap Screw, Hex Head, 5/8"-11 x 3-1/2" | 2 |
| 9 | 98009048 | Cap Screw, Hex Head, 7/16"-14 x 1-1/2" | 4 |
| 10 | 98009050 | Nut, Hex, Nylock, 7/16"-14 | 4 |
| 11 | 98009049 | Washer, Lock, 7/16"..... | 8 |
| 12 | 98009041 | Cap Screw, Hex Head, 5/8"-11 x 2"..... | 2 |
| 13 | 98009062 | Washer, Lock, 5/8"..... | 2 |
| 14 | 98009010 | Cap Screw, Hex Head, 1/2"-13 x 1-1/2" | 2 |
| 15 | 98009013 | Nut, Hex, Nylock, 1/2"-13 | 2 |
| 16 | 98009011 | Washer, Flat, 1/2" | 2 |

SNO-WAY® INTERNATIONAL, INC.



Hartford, WI 53027 USA
 Website: www.snoway.com
 ©2001 Sno-Way® International