



Assembly & Installation Instructions

**FOR
SUBFRAME COMPONENTS PACKAGE 99100422
INCLUDES
SUBFRAME NOSEPIECE 96104534**

**TO FIT
1992-1997 Ford 4X4 F150 & Bronco**



1. THINK SAFETY, ALWAYS WEAR SAFETY GLASSES WHEN PERFORMING THE OPERATIONS PRESCRIBED IN THESE INSTRUCTIONS
2. READ ALL INSTRUCTIONS CAREFULLY BEFORE ATTEMPTING INSTALLATION
3. BEFORE BEGINNING WORK MAKE SURE TO SET PARKING BRAKE AND CHOCK WHEELS



MINIMUM VEHICLE RECOMMENDATIONS

Heavy Duty Alternator
 Heavy Duty Battery
 Heavy Duty Front Springs
 Manufacturer's Snow Plow Package

ASSEMBLY TOOLS NEEDED

Drill Bits 1/4", 17/32"
 Sockets 7/16" -- 1 1/8"
 Wrenches 7/16" -- 1-1/8"
 Torque Wrench
 Center Punch and Hammer
 Hacksaw

NOTE: On some vehicles it may be necessary to use a form of load booster to decrease the vehicle's front suspension sag with snow plow in place. This can be accomplished with the use of supplementary air bags, booster springs, or similar load boosting devices. Since there are different load boosting devices available, it will be up to the customer/end user to decide and purchase the product to suit the application, and not the responsibility of Sno-Way International, Inc.

INSTALLATION NOTES

1. Unless otherwise specified, mount all Sub-Frame Components to vehicle before tightening any hardware.
2. It is recommended that **LOCTITE®**, or similar thread locking product, be used on ALL mounting hardware (i.e. Nuts, Cap Screws, Bolts, etc.).
3. Vehicle should be parked on a level surface with a normal vehicle load on the FRONT suspension.
4. Items in parentheses () refer to quantity required for this step. Items in parentheses with a pound sign (#) indicate the part number as found in the parts list on the last page of this document.
 Example: (2) 5/8" x 1-1/2" Cap Screws (#9).
5. It may be necessary to relocate license plate holder. Check state and local laws for placement, if needed.

2. Mount (1) Front Crossmember (#2) over the frame rails. Align the 3/4" hole in the Front Crossmember with existing slot in the frame horn, making sure the Front Crossmember is to the very front of the slot. Secure loosely using (2) 3/4" x 1 3/4" Cap Screws (#7), (2) 3/4" Flat Washers (#8), and (2) 3/4" Nylock Nuts (#9). Clamp the Front Crossmember to the vehicle frame horns making sure the bottom of the crossmember is parallel to the ground. The remaining holes in the Front Crossmember will be taken care of in a later step.

MOUNTING INSTRUCTIONS

NOTE: (If equipped with stabilizer) - Remove stabilizer plate and bar from attaching point on frame. Retain with hardware for future use if Subframe is removed.

1. Remove the four nuts from the bolts securing the bumper to the bumper support flanges and remove bumper.

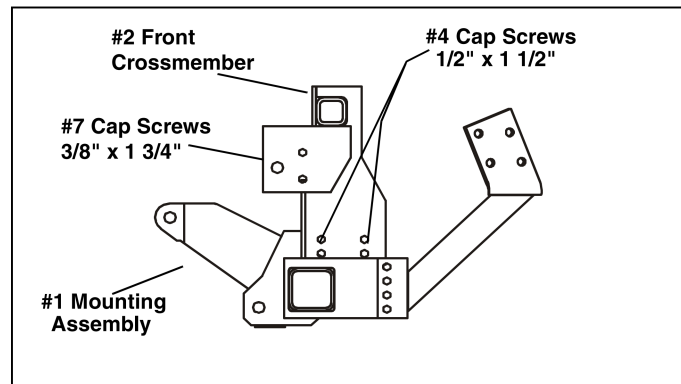

3. Attach (1) Mounting Assembly (#1) to the Front Crossmember. Secure using (4) 1/2" x 1 1/2" Cap Screws (#6) and (4) 1/2" Nylock Nuts (#11). Make Sure that the bottom of the Mounting Assembly is still parallel to the ground.
4. Align the bottom holes of (1) Rear Mounting Bracket (#3) RH & (#4) LH with the outer set of vertical holes on the Mounting Assembly. Secure using (4) 1/2" x 2 1/4" Cap Screws (#13) and (4) 1/2" Nylock Nuts (#11). Clamp the Rear Mounting Brackets to the vehicle frame making sure the brackets are tight with the bottom and sides of the vehicle frame.



WARNING

Beware of brake and fuel lines secured to inside wall of frame rails when drilling holes in vehicle frame!
FAILURE TO HEED CAN RESULT IN SERIOUS INJURY OR DEATH!

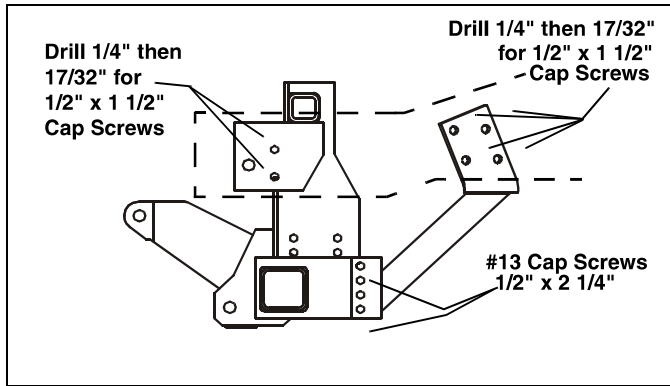

5. Using the (8) holes in the Rear Mounting Brackets (#3) RH & (#4) LH as a template - center punch and drill (8) holes through the outer wall of the frame rails, using a 1/4" and then a 17/32" drill bit. Remove the clamps and secure the Rear Mounting Brackets using (8) 1/2" x 1 1/2" Cap Screws (#6) and (8) Lock Washers (#12) and (4) Nut Plate Assemblies (#5). Insert the Nut Plate Assemblies through the front of the frame rails -- wire handles should be facing the front of the vehicle.
6. Using the holes in the Front Crossmember (#2) as a template - center punch and drill a 1/4" then a 17/32" hole through the outer wall of the vehicle frame rail. Remove the clamps and secure using (4) 1/2" x 1 1/2" Cap Screws (#6), (4) 1/2" Flat Washers (#10), and (4) Nylock Nuts (#11).

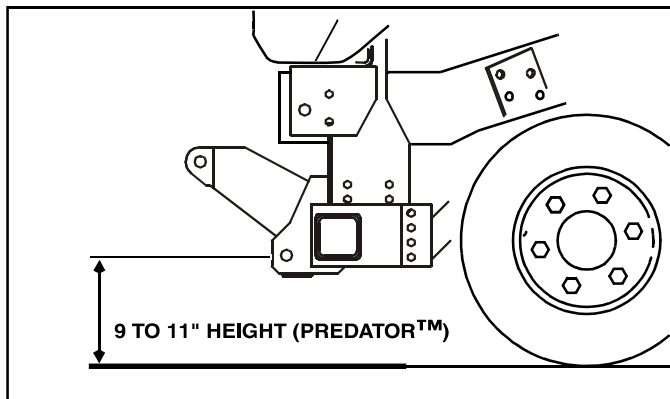

IMPORTANT: Height from the center of the lower plow mounting holes on the sub-frame to the ground should be between 9" and 11" to insure proper operation.

7. Using the Torque Specification Chart, torque all Cap Screws starting at the rear and working forward.
8. Re-install bumper.

TORQUE SPECIFICATIONS FOR STANDARD MACHINE HARDWARE

Bolt Size	GR.2 Dry	GR.5 Dry	GR.8 Dry	Metric Size	GR.8.8 Dry
1/4"	66*	9	12	M8	17
5/16"	11	17	25	M10	35
3/8"	20	30	45	M12	60
7/16"	32	50	70	M14	95
1/2"	50	75	110	M16	155
9/16"	70	110	150		
5/8"	100	150	220		
3/4"	175	260	380		
7/8"	170	430	600		
1"	250	640	900		

Note: These torque values are to be used for all hardware. Unless otherwise specified, all torque values must meet this specification.
 Note: All torque values are in Ft.-Lbs unless otherwise stated
 Note: *In-Lbs

REMEMBER After 5 to 10 hours of snowplow usage, re-torque all Cap Screws!

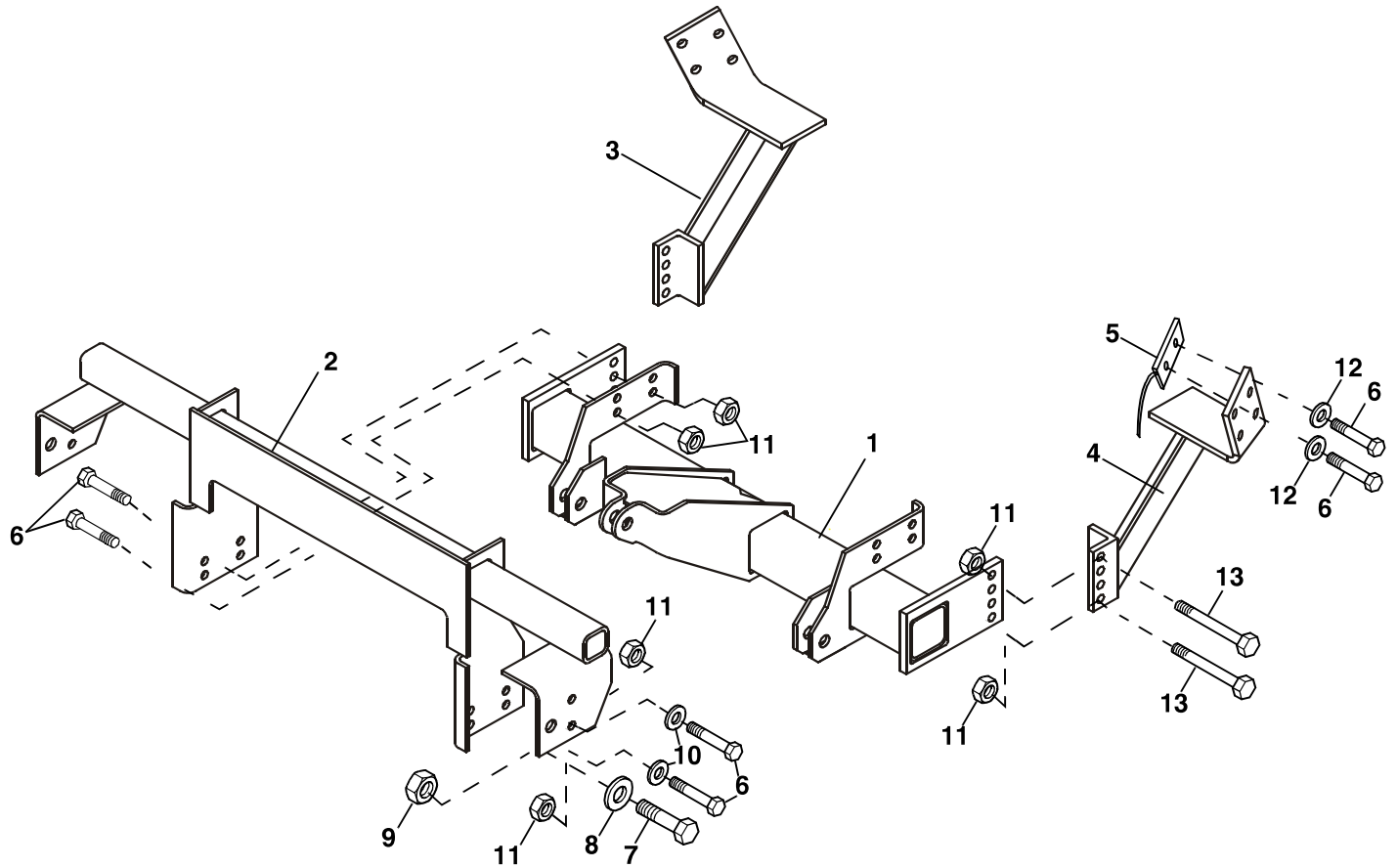

Note: It is recommended that LOCTITE®, or similar thread locking product, be used on ALL mounting hardware (i.e. Nuts, Cap Screws, Bolts, etc.).

ITEM	PART NO.	DESCRIPTION	QTY.
1	96104534	Assembly, Mounting.....	1
2	96104502	Crossmember, Front.....	1
3	96104541	Assembly,Rear Mounting, RH.....	1
4	96104538	Assembly,Rear Mounting, LH.....	1
5	96104753	Assembly, Nut Plate.....	4
6	98009010	Cap Screw, Hex Head, 1/2"-13 NC x 1 1/2".....	16
7	98009098	Cap Screw, Hex Head, 3/4"-10 NC x 1 3/4".....	2
8	98009030	Washer, Flat, 3/4".....	2
9	98009003	Nut, Hex, 3/4"-10 NC Nylock.....	2
10	98009011	Washer, Flat 1/2".....	4
11	98009013	Nut, Hex, 1/2"-13 NC Nylock.....	12
12	98009012	Washer, Lock, 1/2".....	8
13	98100062	Cap Screw, Hex Head, 1/2"-13 NC x 2 1/4".....	4

SNO-WAY® INTERNATIONAL, INC.



Hartford, WI 53027 USA
 Website: www.snoway.com
 ©2003 Sno-Way® International