



**Assembly  
&  
Installation Instructions**

**FOR**  
**SUBFRAME COMPONENTS PACKAGE 99100464**  
**Includes**  
**SUBFRAME NOSE PIECE PACKAGE 96106555**

**TO FIT**

- 1999 - 2002 Chevrolet 2500 Silverado (4X4)**
- 1999 - 2002 GM 2500 Sierra (4X4)**
- 2001 - 2002 Chevrolet K3500 Pickup (4X4)**
- 2001 - 2002 GM K3500 Pickup (4X4)**



1. THINK SAFETY, ALWAYS WEAR SAFETY GLASSES WHEN PERFORMING THE OPERATIONS PRESCRIBED IN THESE INSTRUCTIONS
2. READ ALL INSTRUCTIONS CAREFULLY BEFORE ATTEMPTING INSTALLATION
3. BEFORE BEGINNING WORK MAKE SURE TO SET PARKING BRAKE AND CHOCK



**MINIMUM VEHICLE RECOMMENDATIONS**

- Heavy Duty Alternator
- Heavy Duty Battery
- Manufacturers Snow Plow Package
- Air-adjustable Suspension Kit

**ASSEMBLY TOOLS NEEDED**

- Drill Bits 1/4", 17/32" and 21/32"
- Impact Sockets 7/16" – 1-3/8"
- Impact Sockets, Metric 10mm – 18mm
- Wrenches 7/16" – 1-3/8"
- Wrenches, Metric 10mm - 18mm
- Torque Wrench
- Rat Tail Pry Bar
- Center Punch and Hammer

**INSTALLATION NOTES**

1. Unless otherwise specified, mount all Sub-Frame Components to vehicle before tightening any hardware.
2. It is recommended that **LOCTITE®**, or similar thread locking product, be used on ALL mounting hardware (i.e. Nuts, Cap Screws, Bolts, etc.).
3. Vehicle should be parked on a level surface with a normal vehicle load on the FRONT suspension.
4. Items in parentheses ( ) refer to quantity required for this step. Items in parentheses with a pound sign (#) indicate the part number as found in the parts list on the last page of this document.  
Example: (2) 5/8"-11 x 1-1/2" Cap Screws (#7).
5. It maybe necessary to relocate license plate holder. Relocate under the driver's side headlight by drilling new holes in the bumper. Check state and local laws for placement, if needed.

1/2" Cap Screws (#7), (2) 5/8" Lock Washers (#8) into the Nut Plate (#5) which is inserted through the front of the frame rail. Repeat this step for the Mounting Bracket Assembly, RH (#3).

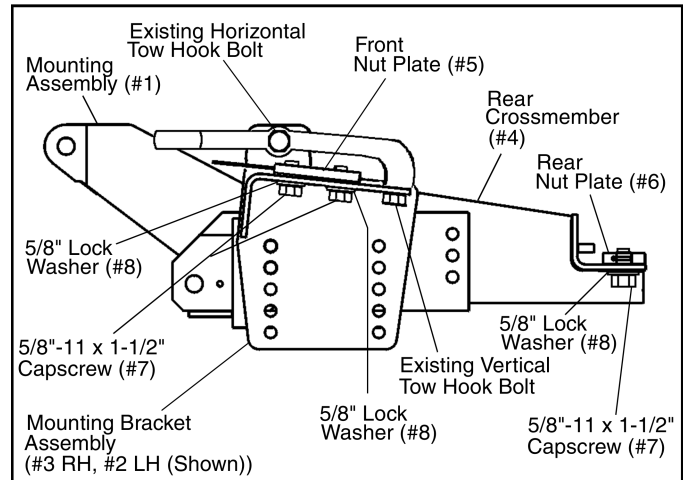

**MOUNTING INSTRUCTIONS**

1. Remove the bumper with the air dam attached. Retain with hardware for replacement at the end of the installation. Typically, the front fascia or air dam of the vehicle will need to be modified to accommodate the Subframe.
2. Remove the splash shield from underneath the vehicle. It should be possible to reinstall the splash shield on the vehicle, above the Mounting Assembly (#1). (Otherwise, retain with hardware for future use.)
3. Remove the bottom vertical tow hook bolts. Also, remove the tow hook bolts from the side of the frame. (Both sides.)
4. Install the Mounting Bracket Assembly, LH (#2) by aligning the back hole with the vehicle frame tow hook hole on the inside of the vehicle frame rail. Secure bottom tow hook hole with (1) M12-1.25 x 40 Cap Screw (#14). Secure the upper tow hook hole with (1) M12-1.25 x 40 Cap Screw (#14) and (1) 1/2" Lock Washer (#13). The middle hole on the bottom of the frame should align with the middle hole of the mounting bracket. Using the front hole as a template, drill a 1/4" pilot hole, then drill to 21/32" through the bottom of the truck frame. Install with (2) 5/8"-11 x 1

5. Position the Rear Crossmember (#4) under the lip of the truck's cross frame. Attach the Rear Crossmember outer holes using (2) 5/8"-11 x 1-1/2" Cap Screws (#7), (2) 5/8" Lock Washers (#8), (2) 5/8" Flat Washers (#15) and (2) Rear Nut Plates (#6) to the vehicle frame. For the inner holes, use the (2) M10-1.50 x 35 Cap Screws (#9), (2) 10mm Lock Washers (#10) and (2) 1/2" Flat Washers (#16).
6. Attach the Mounting Assembly (#1) to the Front Mounting Brackets (#2 & #3), using (8) 1/2"-13 x 1-1/2" Cap Screws (#11) and (6) 1/2" Nylock Nuts (#12).

*NOTE: Only (6) Nylock Nuts are needed because of the threaded holes in the Mounting Assembly.*

7. Attach the Mounting Assembly to the Rear Crossmember (#4) using (8) 1/2"-13 x 1-1/2" Cap Screws (#11) and (8) 1/2" Nylock Nuts (#12).
8. Using the Torque Specification Chart given, torque all bolts starting at the rear and working forward.
9. Re-install bumper onto the vehicle.

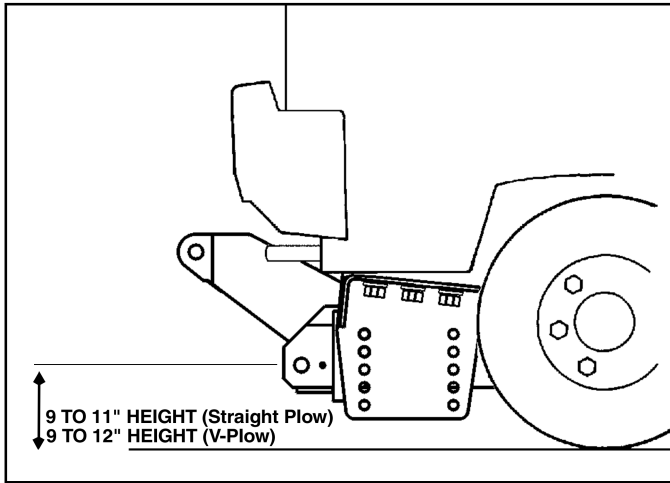

**IMPORTANT:** Height from the center of the lower plow mounting holes on the Sub-Frame to the ground should be between 9" and 11" for Straight Plows, and between 9" and 12" for V-Plows to insure proper operation.

TORQUE SPECIFICATIONS FOR STANDARD MACHINE HARDWARE					
Bolt Size	GR.2 Dry	GR.5 Dry	GR.8 Dry	Metric Size	GR.8.8 Dry
1/4"	66*	9	12	M8	17
5/16"	11	17	25	M10	35
3/8"	20	30	45	M12	60
7/16"	32	50	70	M14	95
1/2"	50	75	110	M16	155
9/16"	70	110	150		
5/8"	100	150	220		
3/4"	175	260	380		
7/8"	170	430	600		
1"	250	640	900		

These torque values are to be used for all hardware. Unless otherwise specified, all torque values must meet this specification.  
 All torque values are in Ft.-Lbs unless otherwise stated  
 \*In-Lbs

**REMEMBER** After 5 to 10 hours of snowplow usage, re-torque all Cap Screws!

# PARTS LIST

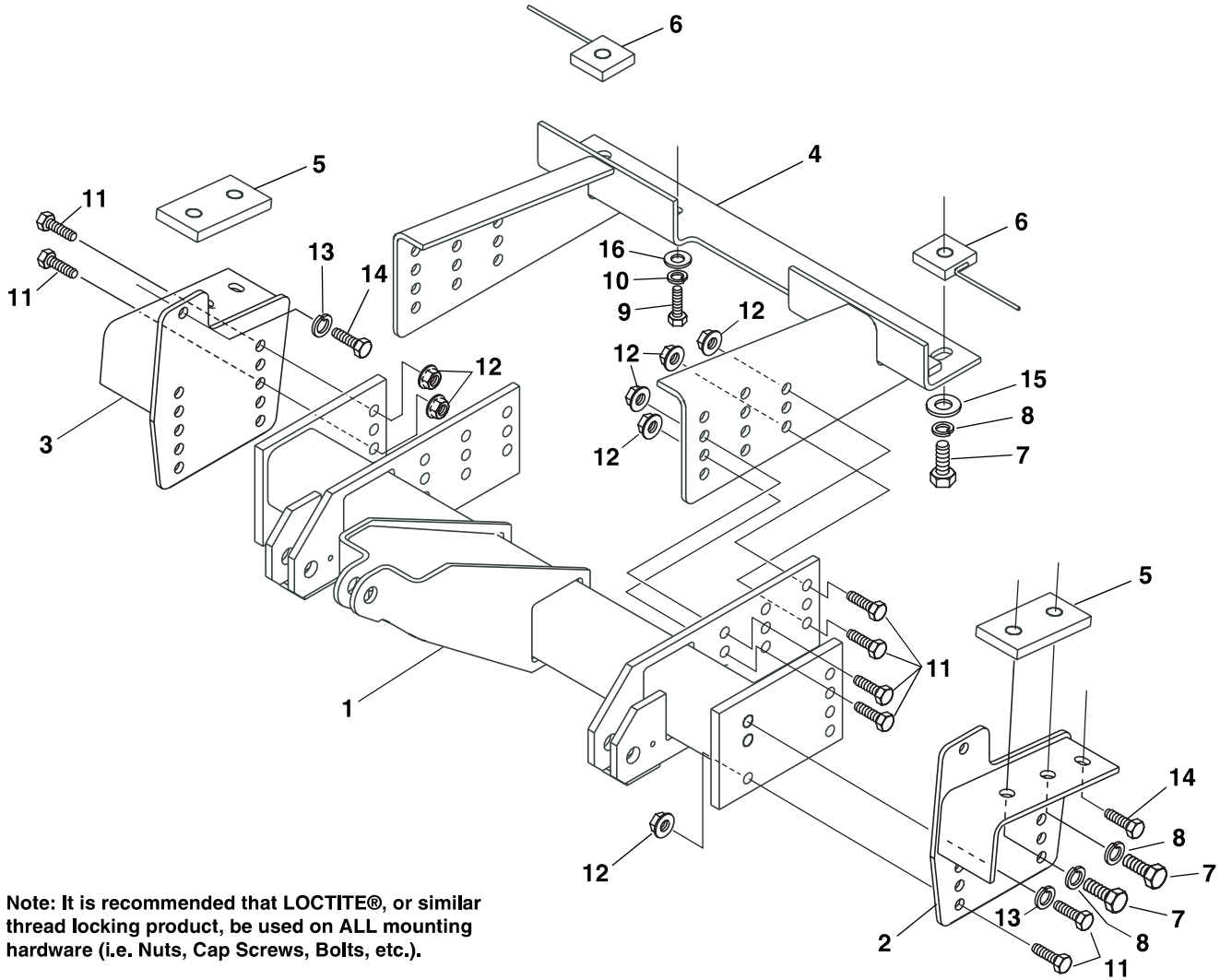

Note: It is recommended that LOCTITE®, or similar thread locking product, be used on ALL mounting hardware (i.e. Nuts, Cap Screws, Bolts, etc.).

ITEM	PART NO.	DESCRIPTION	QTY.
1	96106555	Assembly, Mounting.....	1
2	96106553	Assembly, Mounting Bracket, LH.....	1
3	96106554	Assembly, Mounting Bracket, RH.....	1
4	96104881	Assembly, Rear Crossmember.....	1
5	96103813	Plate, Nut.....	2
6	96103518	Assembly, Rear Nut Plate.....	2
7	98009115	Cap Screw, Hex Head, 5/8"-11 x 1-1/2".....	6
8	98009062	Washer, Lock, 5/8".....	6
9	98009060	Cap Screw, Hex Head, M10-1.50 x 35.....	2
10	98100048	Washer, Lock, 10mm.....	2
11	98009010	Cap Screw, Hex Head, 1/2"-13 x 1-1/2".....	16
12	98009013	Nut, Hex Nylock, 1/2"-13.....	14
13	98009012	Washer, Lock, 1/2".....	4
14	98009054	Cap Screw, Hex Head, M12-1.25 x 40.....	4
15	98009039	Washer, Flat, 5/8".....	2
16	98009011	Washer, Flat, 1/2".....	2

SNO-WAY® INTERNATIONAL, INC.

Hartford, WI 53027 USA  
 Website: [www.snoway.com](http://www.snoway.com)  
 ©2004 Sno-Way® International

