



Assembly & Installation Instructions

**FOR
SUBFRAME COMPONENTS PACKAGE 99100521
AND
SUBFRAME NOSE PIECE PACKAGE 96105606**

**TO FIT
1999 - 2002 GMC 1500 SIERRA 4 x 4 (NEW BODY STYLE) AND YUKON
1999 - 2002 CHEVY 1500 SILVERADO**



1. **THINK SAFETY, ALWAYS WEAR SAFETY GLASSES WHEN PERFORMING THE OPERATIONS PRESCRIBED IN THESE INSTRUCTIONS**
2. **READ ALL INSTRUCTIONS CAREFULLY BEFORE ATTEMPTING INSTALLATION**
3. **BEFORE BEGINNING WORK MAKE SURE TO SET PARKING BRAKE AND CHOCK WHEELS**



MINIMUM VEHICLE RECOMMENDATIONS

Heavy Duty Alternator
 Heavy Duty Battery
 Manufacturer's Snow Plow Package

NOTE: On some vehicles it may be necessary to use a form of load booster to decrease the vehicle's front suspension sag with the snow plow in place. This can be accomplished with the use of supplementary air bags, booster springs, or similar load boosting devices. Since there are different load boosting devices available, it will up to the customer/end user to decide and purchase the product to suit the application, and not the responsibility of Sno-Way International, Inc.

ASSEMBLY TOOLS NEEDED

Drill Bits	1/4", 17/32", 21/32"
Impact Sockets	7/16" – 1-3/8"
Impact Sockets, Metric	10mm - 19mm
Wrenches	7/16" – 1-3/8"
Wrenches, Metric	10mm - 19mm
Torque Wrench	
Hacksaw	
Center Punch and Hammer	

INSTALLATION NOTES

1. **Unless otherwise specified, mount all Sub-Frame Components to vehicle before tightening any hardware.**
2. **It is recommended that LOCTITE®, or similar thread locking product, be used on ALL mounting hardware (i.e. Nuts, Cap Screws, Bolts, etc.).**
3. Vehicle should be parked on a level surface with a normal vehicle load on the FRONT suspension.
4. Items in parentheses () refer to quantity required for this step. Items in parentheses with a pound sign (#) indicate the part number as found in the parts list on the last page of this document.
 Example: (10) Washer, Lock, 1/2" (#8).
5. It maybe necessary to relocate license plate holder. Check state and local laws for placement, if needed.

Lock Washer (#7) provided.

4. Enlarge 1/2" holes in the truck frame (approximately 15" apart) that aligns with the slotted holes in the Rear Crossmember (#2) with a 21/32" drill.
5. The Rear Crossmember can be mounting to the vehicle frame with (2) Cap Screws (#10) and (2) Nut Plates (#6) with the lock and flat washers provided. Make sure the Rear Crossmember is tight with the vehicle frame and parallel to ground.
6. Using the holes in the Rear Crossmember (that fits against the truck frame) as a template, center punch and drill through the vehicle frame rail with a 1/4" drill. Remove the Rear Crossmember and drill through the vehicle frame rail using 21/32" drill.
7. Attach the Rear Crossmember with (4) 5/8" x 1/2" Cap Screws (#10), (4) Lock Washers (#9) (6) Flat Washers (#11) and (4) Nut Plates (#6) to the vehicle frame. Use (2) Flat washers (#11) for the slotted holes.
8. Attach the Mounting Assembly (#1) to the side mounting LH (#3) and RH (#4) using (8) 1/2" x 1 1/2" Cap Screws (#12). Secure using (2) Lock Washers (#7) into the threaded holes, for the rest use (6) 1/2" Nylock Nuts (#13).
9. Attach the Rear Crossmember (#2) to the Mounting Assembly using (4) 1/2" x 1 1/2" Cap Screws (#12) and (4) 1/2" Nylock Nuts (#13).
10. Using the Torque Specification chart below, torque all bolts.
11. Reinstall bumper and all other items previously removed.

MOUNTING INSTRUCTIONS

1. Remove the bumper and retain with hardware for replacement at the end of the installation. Remove the tow hooks and retain hardware for replacement in step 3.
2. Remove the splash shield from underneath the vehicle. Retain with hardware for future use.
3. Insert Nut Plates (#5) into the truck frame where the tow hooks were removed. Align the threaded holes over the existing frame holes (approximately 4" behind the back tow hook bolt hole). Install the Side Mountings, RH (#3) and LH (#4) by aligning the side mounting holes with the existing vehicle frame rail holes provided for mounting the tow hooks. Install (2) 5/8" x 1 1/2" Cap Screws (#10) with (2) 5/8" Lock Washers (#9) into Nut Plates (#5). Reinstall the tow hooks using the existing long bolts and nuts. Replace the smaller bottom mounting tow hook screws with (2) Metric Cap Screws M12-1.75 x 50 (#8) and (2) 1/2"

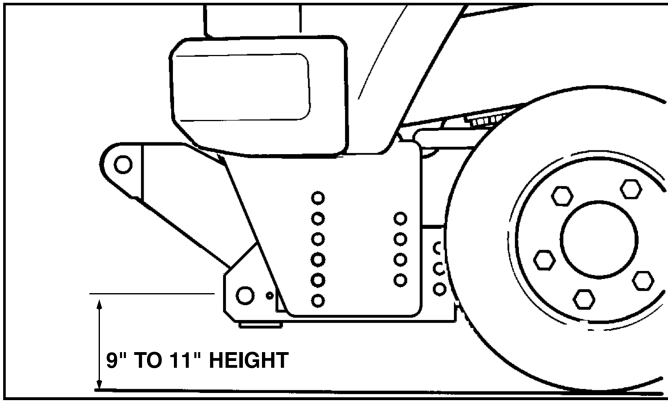

IMPORTANT: Height from the center of the lower Plow Mounting holes on the Sub-Frame to the ground should be between 9" and 11" to insure proper operation.

TORQUE SPECIFICATIONS FOR STANDARD MACHINE HARDWARE

Bolt Size	GR.2 Dry	GR.5 Dry	GR.8 Dry	Metric Size	GR.8.8 Dry
1/4"	66*	9	12	M8	17
5/16"	11	17	25	M10	35
3/8"	20	30	45	M12	60
7/16"	32	50	70	M14	95
1/2"	50	75	110	M16	155
9/16"	70	110	150		
5/8"	100	150	220		
3/4"	175	260	380		
7/8"	170	430	600		
1"	250	640	900		

Note: These torque values are to be used for all hardware. Unless otherwise specified, all torque values must meet this specification.
 Note: All torque values are in Ft.-Lbs unless otherwise stated
 Note: *In-Lbs

REMEMBER After 5 to 10 hours of snowplow usage, re-torque all Cap Screws!

PARTS LIST

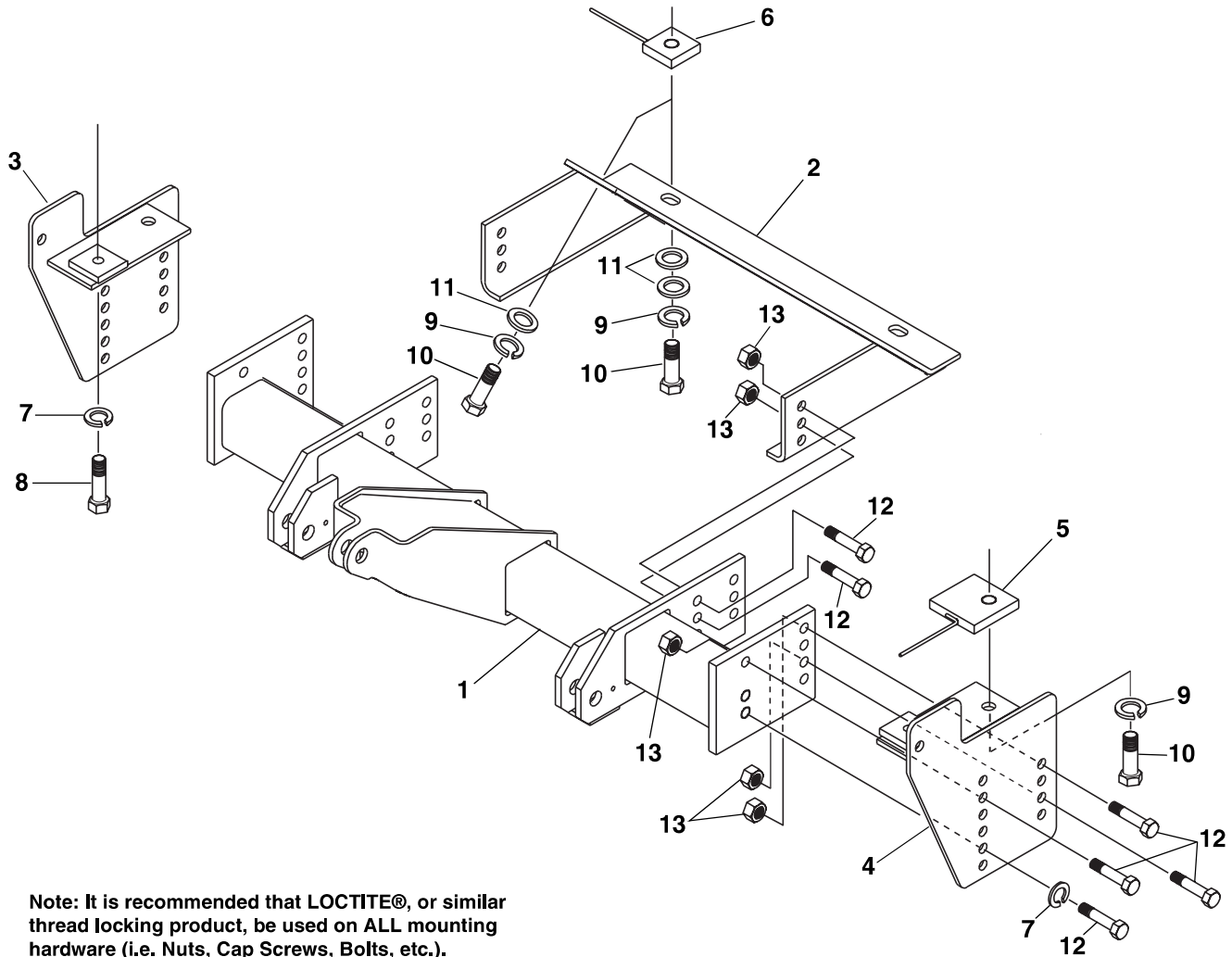

Note: It is recommended that LOCTITE®, or similar thread locking product, be used on ALL mounting hardware (i.e. Nuts, Cap Screws, Bolts, etc.).

ITEM	PART NO.	DESCRIPTION	QTY.
1	96105606	Assembly, Mounting	1
2	96105641	Assembly, Rear Crossmember.....	1
3	96105723	Side Mounting, RH.....	1
4	96105724	Side Mounting, LH.....	1
5	96103475	Assembly, Front Nut Plate	2
6	96103518	Assembly, Rear Nut Plate	4
7	98009012	Washer, Lock 1/2"	4
8	98100188	Cap Screw, Hex Head. Metric M12-1.75 x 50	2
9	98009062	Washer, Lock 5/8"	6
10	98009115	Cap Screw, Hex Head, 5/8"-11 x 1 1/2".....	6
11	98009039	Washer, Flat 5/8".....	6
12	98009010	Cap Screw, Hex Head, 1/2"-13 x 1 1/2".....	12
13	98009013	Nut, Hex, Nylock 1/2"-13	10

SNO-WAY® INTERNATIONAL, INC.



Hartford, WI 53027 USA
 Website: www.snoway.com
 ©2003 Sno-Way® International