

SNO-WAY[®]

SNOW & ICE CONTROL EQUIPMENT

Assembly & Installation Instructions

**FOR
SUBFRAME COMPONENTS PACKAGE 99100594**

**TO FIT
2003 & LATER DODGE 2500, 3500 4 x 4**



1. THINK SAFETY, ALWAYS WEAR SAFETY GLASSES WHEN PERFORMING THE OPERATIONS PRESCRIBED IN THESE INSTRUCTIONS
2. READ ALL INSTRUCTIONS CAREFULLY BEFORE ATTEMPTING INSTALLATION
3. BEFORE BEGINNING WORK MAKE SURE TO SET PARKING BRAKE AND CHOCK WHEELS



MINIMUM VEHICLE RECOMMENDATIONS

Heavy Duty Alternator
 Heavy Duty Battery
 Manufacturers Snow Plow Package

NOTE: On some vehicles it may be necessary to use a form of load booster to decrease the vehicle's front suspension sag with the snow plow in place. This can be accomplished with the use of supplementary air bags, booster springs, or similar load boosting devices. Since there are different load boosting devices available, it will up to the customer/end user to decide and purchase the product to suit the application, and not the responsibility of Sno-Way International, Inc.

ASSEMBLY TOOLS NEEDED

Drill Bits	1/4", 17/32", 21/32"
Impact Sockets	7/16" - 1-3/8"
Metric Sockets	10mm - 18mm
Wrenches	7/16" - 1-3/8"
Metric Wrenches	10mm - 18mm
Torque Wrench	
Center Punch and Hammer	
Hacksaw	
Clamping Devices ("C" or bar type)	
Rat Tail Pry Bar	

INSTALLATION NOTES

1. Unless otherwise specified, mount all Subframe Components to vehicle before tightening any hardware.
2. It is recommended that LOCTITE®, or similar thread locking product, be used on ALL mounting hardware (i.e. Nuts, Cap Screws, Bolts, etc.).
3. Vehicle should be parked on a level surface with a normal vehicle load on the FRONT suspension.
4. Items in parentheses () refer to quantity required for this step. Items in parentheses with a pound sign (#) indicate the part number as found in the parts list on the last page of this document.
 Example: (2) 1/2" Lock Washers (#9).
5. It maybe necessary to relocate license plate holder. Check state and local laws for placement, if needed.

the bottom of the truck frame and the Front Mounting Assembly. Install a 1/2"-13 x 1-1/2" Cap Screw (#8) and 1/2" Lock Washer (#9) through the Front Mounting Assembly, Shim Plate and truck frame, securing finger-tight to a Wire Nut (#7) inserted from the end of the frame rail. Place a second Shim Plate (#6) between the rear mounting hole in the Front Mounting Assembly and the truck frame, and secure finger-tight with the (#8) Cap Screw, (#9) Lock Washer and (#7) Wire Nut. Replace truck bumper using the hardware from Step #1.

3. Install the Mounting Assembly (#1) between the Front Mounting Assemblies (#2 and #3) using (8) 1/2"-13 x 1-1/2" Cap Screws (#8), (2) 1/2" Lock Washers (#9) (in threaded holes), and (6) 1/2" Nylock Nuts (#10).
4. Assemble Rear Brackets, LH (#4) and RH (#5), onto the back plates of the Mounting Assembly (#1) using (2) 1/2"- 13 x 1-1/2" Cap Screws (#8) and (2) 1/2"-13 Nylock Nuts (#10) per side. The rear mount supports of the Rear Brackets (#4 and #5) should contact the outside and bottom of the truck frame. If necessary, adjust the vertical mounting location of the Rear Brackets (#4 and #5) on the Mounting Assembly (#1) for proper alignment. With the Rear Brackets in position, use the rear mounting holes as templates, then center punch and drill 1/4" pilot holes through one side of the frame rail in each location. Drop the Rear Brackets out of the way and re-drill the pilot holes to 21/32". Install Rear Brackets (#4 and #5) using (1) 5/8"-11 x 4" Cap Screw (#11), (1) 5/8" Flat Washer (#12), and (1) 5/8"-11 Nylock Nut (#13) per side.
5. With all components in place, tighten all hardware. The mounting hardware for the Front Mounting Assemblies (#2 and #3) should be tightened first, then the hardware for the Mounting Assembly (#1). Tighten remaining hardware. **(Do not over-tighten the upper mounting hardware for the Rear Brackets (#4 and #5) as it could crush the truck frame!)**

MOUNTING INSTRUCTIONS

1. Remove the mounting hardware connecting the truck bumper to the driver side of the truck frame. Place the LH Front Mounting Assembly (#2) up against the bumper bracket, aligning the two front holes in the Front Mounting Assembly with the bumper mounting holes. Temporarily secure using (2) 1/2"-13 x 4-1/2" Cap Screws (#14), (4) 1/2" Flat Washers (#15) (2 on each side of the frame) and (2) 1/2"-13 Nylock Nuts (#10). Using the rear and bottom mounting holes of the Front Mounting Assembly as a template, center punch and drill a 1/4" pilot hole in each location, then drill both holes to 17/32". **(Do not drill through both sides of the frame rail.)** Repeat the process on the passenger side for the RH Front Mounting Assembly (#3).
2. Remove both Front Mounting Assemblies (#2 and #3) and the truck bumper. Realign the LH Front Mounting Assembly (#2) with the previously drilled holes in the left side frame. Position a Shim Plate (#6) between

6. Using the torque specification chart below, torque all cap screws.

TORQUE SPECIFICATIONS FOR STANDARD MACHINE HARDWARE					
Bolt Size	GR.2 Dry	GR.5 Dry	GR.8 Dry	Metric Size	GR.8.8 Dry
1/4"	66*	9	12	M8	17
5/16"	11	17	25	M10	35
3/8"	20	30	45	M12	60
7/16"	32	50	70	M14	95
1/2"	50	75	110	M16	155
9/16"	70	110	150		
5/8"	100	150	220		
3/4"	175	260	380		
7/8"	170	430	600		
1"	250	640	900		

Note: These torque values are to be used for all hardware. Unless otherwise specified, all torque values must meet this specification.
 Note: All torque values are in Ft.-Lbs unless otherwise stated
 Note: *In-Lbs

REMEMBER After 5 to 10 hours of snowplow usage, re-torque all Cap Screws!

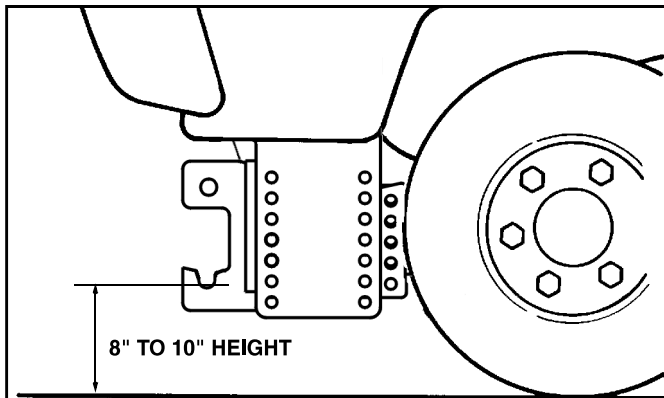

IMPORTANT: Height from the bottom of the lower pin slots on the Subframe to the ground should be between 8" and 10" to ensure proper operation.

PARTS LIST

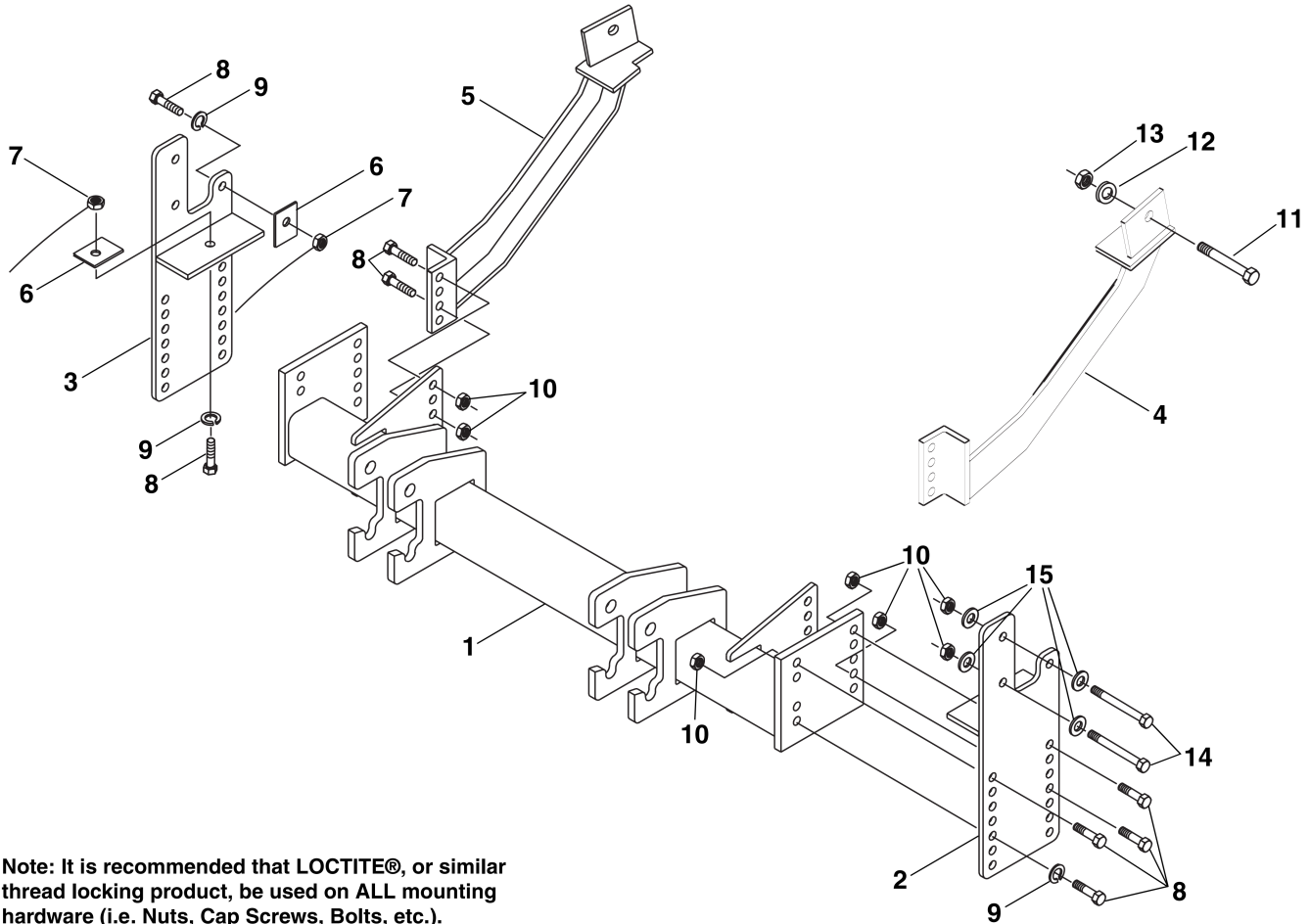

Note: It is recommended that LOCTITE®, or similar thread locking product, be used on ALL mounting hardware (i.e. Nuts, Cap Screws, Bolts, etc.).

ITEM	PART NO.	DESCRIPTION	QTY.
1	96106377	Assembly, Mounting	1
2	96106350	Assembly, Front Mounting, LH.....	1
3	96106351	Assembly, Front Mounting, RH	1
4	96107028	Bracket, Rear, LH	1
5	96107029	Bracket, Rear, RH.....	1
6	96103283	Plate, Shim	4
7	96106421	Assembly, Nut Wire	4
8	98009010	Cap Screw, Hex Head, 1/2"-13 x 1-1/2".....	16
9	98009012	Washer, Lock, 1/2".....	6
10	98009013	Nut, Hex, Nylock, 1/2".....	14
11	98009194	Cap Screw, Hex Head, 5/8"-11 x 4"	2
12	98100107	Washer, Flat (Wide), 5/8".....	2
13	98009038	Nut, Hex, Nylock, 5/8".....	2
14	98009055	Cap Screw, Hex Head, 1/2"-13 x 4-1/2".....	4
15	98009011	Washer, Flat, 1/2"	8

SNO-WAY® INTERNATIONAL, INC.



Hartford, WI 53027 USA
 Website: www.snoway.com
 ©2005 Sno-Way® International