



Assembly & Installation Instructions

**FOR
SUBFRAME COMPONENTS PACKAGE 99100089
AND
SUBFRAME NOSE PIECE PACKAGE 96103002**

**TO FIT
1980 - 1991 FORD F150 & BRONCO 4x4**



1. **THINK SAFETY, ALWAYS WEAR SAFETY GLASSES WHEN PERFORMING THE OPERATIONS PRESCRIBED IN THESE INSTRUCTIONS**
2. **READ ALL INSTRUCTIONS CAREFULLY BEFORE ATTEMPTING INSTALLATION**
3. **BEFORE BEGINNING WORK MAKE SURE TO SET PARKING BRAKE AND CHOCK WHEELS**



MINIMUM VEHICLE RECOMMENDATIONS

Heavy Duty Front Springs Heavy Duty Alternator
 Manufacturers Snow Plow Package Heavy Duty Battery

NOTE: On some vehicles it may be necessary to use a form of load booster to decrease the vehicle's front suspension sag with the snow plow in place. This can be accomplished with the use of supplementary air bags, booster springs, or similar load boosting devices. Since there are different load boosting devices available, it will up to the customer/end user to decide and purchase the product to suit the application, and not the responsibility of Sno-Way International, Inc.

ASSEMBLY TOOLS NEEDED

Drill Bits 1/4", 17/32"
 Sockets 7/16" – 1-1/8"
 Wrenches 7/16" – 1-1/8"
 Torque Wrench
 Center Punch and Hammer
 Hacksaw
 Clamping device ("C", Bar, type device...)

INSTALLATION NOTES

1. **Unless otherwise specified, mount all Sub-Frame Components to vehicle before tightening any hardware.**
2. **It is recommended that LOCTITE®, or similar thread locking product, be used on ALL mounting hardware (i.e. Nuts, Cap Screws, Bolts, etc.).**
3. Vehicle should be parked on a level surface with a normal vehicle load on the FRONT suspension.
4. Items in parentheses () refer to quantity required for this step. Items in parentheses with a pound sign (#) indicate the part number as found in the parts list on the last page of this document.
 Example: (2) 5/8" x 1-1/2" Cap Screws (#18).
5. It may be necessary to relocate license plate holder. Check state and local laws for placement, if needed.

MOUNTING INSTRUCTIONS

NOTE: On F150 only, the Sway Bar needs to be removed, if there is room reinstall. Consult with the customer about this.

NOTE: It may be necessary to use Spacer Plate(s) (#8) between the vehicle frame and the Front Crossmember. If two are needed, then place the plates on either side of the vehicle.

• Vehicles from 1980 - 1986

1. Remove front bumper from the vehicle.
2. Mount Front Crossmember (#2) over vehicle frame horns. Leave approximately a 1/4" gap between the top of the frame horn and the Front Crossmember. Clamp in place keeping face of Crossmember perpendicular to ground. Using side holes in the Front Crossmember as a template, drill (4) 1/4" holes then 17/32" holes through outer wall of vehicle frame. Secure tightly using (4) 1/2" x 1-1/2" Cap Screws (#14), (4) Flat Washers (#15) and (4) Nylock Nuts (#17) provided.
3. Reinstall front bumper, using (4) 1/2" x 2-1/4" Carriage Bolts (#13), (4) Flat Washer (#15), and (4) Nylock Nuts (#17) provided, placing (4) Spacer Tubes (#10)

between bumper and frame.

• Vehicles from 1987 - 1991

1. Remove Front bumper from vehicle.
2. Mount Front Crossmember (#2) over vehicle frame horns, getting mounting holes close to holes in vehicle frame.
3. Raise front bumper and align holes in bumper brackets with holes in Front Crossmember and with holes in frame. Secure tightly using (4) 1/2" x 1-1/2" Cap Screws (#14), (4) Flat Washers (#15), and (4) Nylock Nuts (#17) provided.

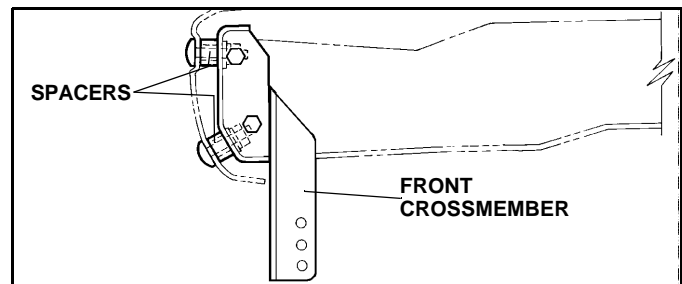

NOTE: Keep face of Front Crossmember perpendicular to ground when tightening.

• Mounting Instructions for all Vehicles

4. Install Rear Crossmember (#3) onto Sub-Frame Nosepiece (#1) using (2) 5/8" x 1-1/2" Cap Screws (#18) at the rear holes, and (2) 5/8" x 3-1/2" Cap Screws (#19) at the front holes, (4) 5/8" Lock Washers (#12) and (4) Nylock Nuts (#21).

IMPORTANT: The Cap Screws securing the Sub-Frame to the Front Crossmember must be staggered with the front bolts being positioned in a lower set of holes than the side bolts. (Unless the holes are in the lowest possible position)

5. Mount Nose Piece with Rear Crossmember to Front Crossmember using the 9" to 11" ground clearance as a guide. Secure using (4) 5/8" x 1-1/2" Cap Screws (#18), (4) Flat Washer (#20) and (4) Nylock Nuts (#21).

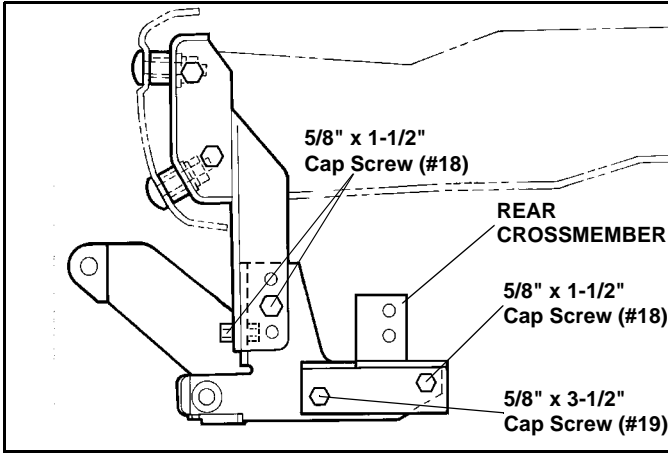

IMPORTANT: height from the center of the lower Plow Mounting holes on the Sub-Frame to the ground should be between 9" and 11" to insure proper operation.

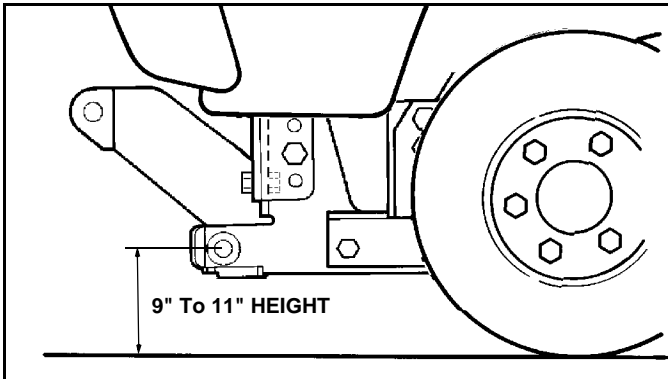

NOTE: It may be necessary to use Shim Plate (#9) & (#11) between the Rear Crossmember (#3) and the Rear Mounting Brackets (#4) & (#5).

6. Align the Rear Mounting Brackets (#4) & (#5) adjustment holes with the holes in the Rear Crossmember (#3) and from the engine side insert (4) 5/8" x 3-1/2" Cap Screws (#19) with (4) 5/8" Lock Washers (#12) into the holes. Clamp the Rear Mounting Brackets to the vehicle frame making sure the brackets are tight with the bottom and sides of the vehicle frame. Secure Mounting Brackets to Rear Crossmember using (4) 5/8" Nylock Nuts (#21).

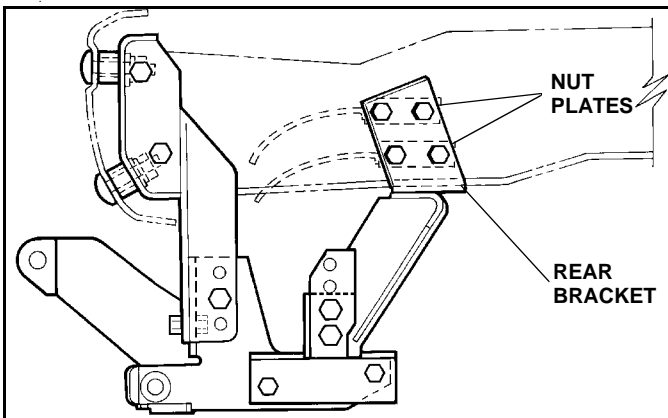

WARNING

Beware of brake and fuel lines secured to inside wall of frame rails when drilling holes in vehicle frame!

FAILURE TO HEED CAN RESULT IN SERIOUS INJURY OR DEATH.

7. Using the (8) holes in the Rear Mounting Brackets (#4) & (#5) as a template center punch and drill (8) holes, through the vehicle frame rails, by first using a 1/4" and then a 17/32" drill bits. Remove clamps and secure Brackets using (8) 1/2" x 1-1/2" Cap Screws (#14) and (8) 1/2" Lock Washers (#16) and on the engine side of the frame rails using (4) Nut Plate Assembly (#6) & (#7). Wire Handles should face to the front of the vehicle.

8. Using the Torque Specification Chart below torque all cap screws starting at the rear and working forward.

TORQUE SPECIFICATIONS FOR STANDARD MACHINE HARDWARE

Bolt Size	GR.2 Dry	GR.5 Dry	GR.8 Dry	Metric Size	GR.8.8 Dry
1/4"	66*	9	12	M8	17
5/16"	11	17	25	M10	35
3/8"	20	30	45	M12	60
7/16"	32	50	70	M14	95
1/2"	50	75	110	M16	155
9/16"	70	110	150		
5/8"	100	150	220		
3/4"	175	260	380		
7/8"	170	430	600		
1"	250	640	900		

Note: These torque values are to be used for all hardware. Unless otherwise specified, all torque values must meet this specification.
Note: All torque values are in Ft.-Lbs unless otherwise stated
Note: *In-Lbs

REMEMBER After 5 to 10 hours of snowplow usage, re-torque all cap screws!

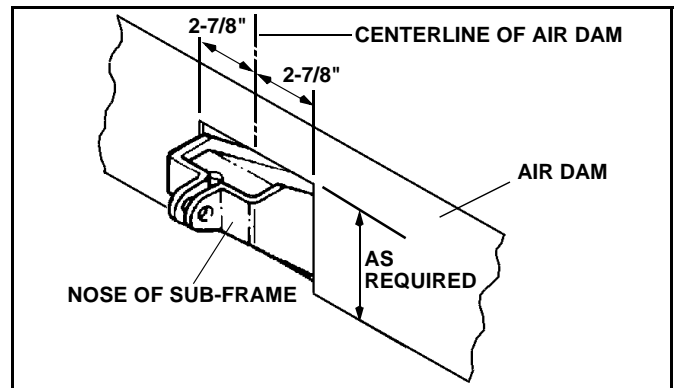

NOTE: Front air dam can be modified to clear subframe by cutting dam to allow clearance for nose of Subframe. To modify air dam measure 2-7/8" from each side of center and remove a section as required from between the marked areas to provide clearance for nose of subframe.

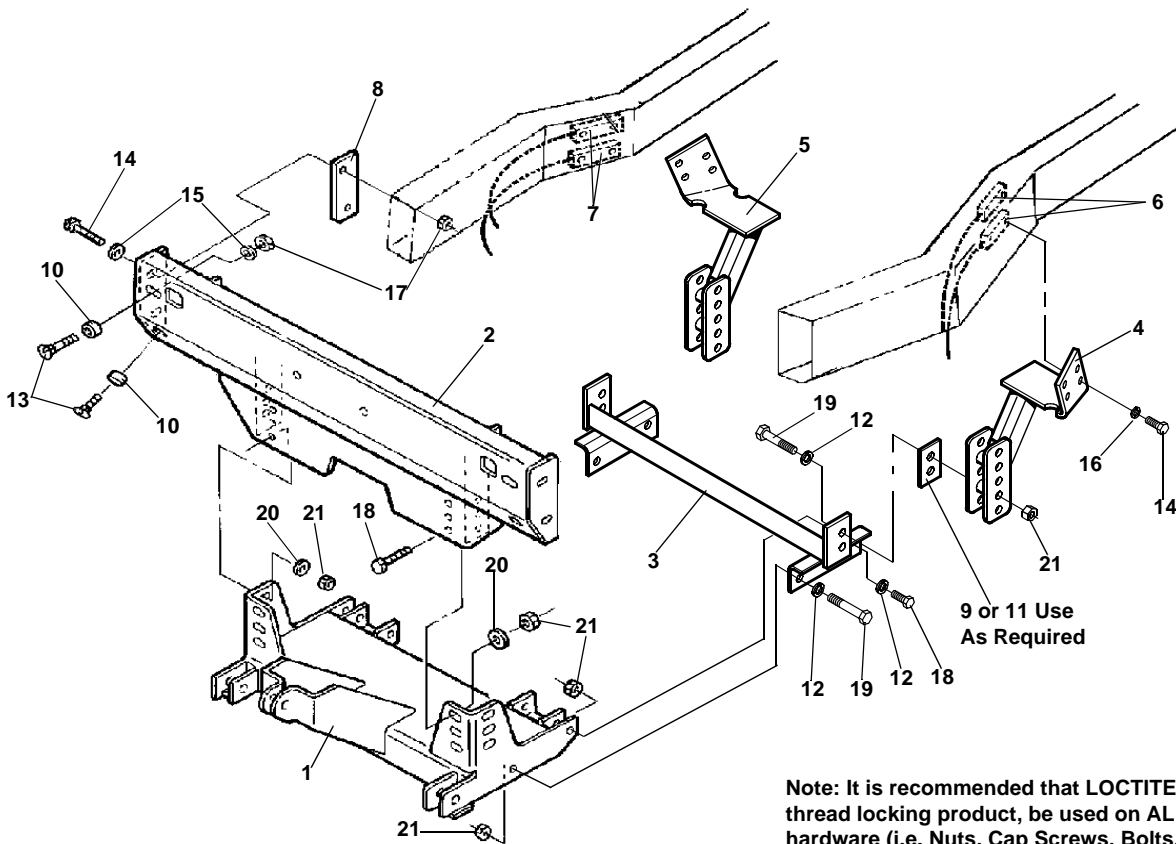

Note: It is recommended that LOCTITE®, or similar thread locking product, be used on ALL mounting hardware (i.e. Nuts, Cap Screws, Bolts, etc.).

ITEM	PART NO.	DESCRIPTION	QTY.
1	96103002	Sub-Frame, Nose Piece (96102896).....	1
2	96101391	Crossmember, Front	1
3	96101387	Crossmember, Rear	1
4	96103070	Bracket, Rear Mounting, LH	1
5	96103071	Bracket, Rear Mounting, RH.....	1
6	96100939	Plate, Nut, Left.....	2
7	96100938	Plate, Nut, Right	2
8	96101400	Plate, Spacer	4
9	96102214	Plate, Shim	2
10	96101465	Tube, Spacer	4
11	96103075	Plate, Shim	2
12	98009062	Washer, Lock, 5/8".....	8
13	98100067	Bolt, Carriage, 1/2"-13 x 2-1/4".....	4
14	98009010	Cap Screw, Hex Head, 1/2"-13 x 1-1/2".....	12
15	98009011	Washer, Flat, 1/2"	8
16	98009012	Washer, Lock, 1/2".....	8
17	98009013	Nut, Hex, 1/2"-13 Nylock	8
18	98009115	Cap Screw, Hex Head, 5/8"-11 x 1-1/2"	8
19	98009042	Cap Screw, Hex Head, 5/8"-11 x 3-1/2"	6
20	98009039	Washer, Flat, 5/8"	4
21	98009038	Nut, Hex, 5/8"-11 Nylock	12

SNO-WAY® INTERNATIONAL, INC.

