



Parts & Installation Instructions

SV & SV² 8.5, 9.5 & 10.5 and SVLD 7.5 Snow Plow

PARTS LIST

Item	Part No. SVLD 7.5	Part No. SV 8.5	Part No. SV ² 8.5	Part No. SV 9.5	Part No. SV ² 9.5	Part No. SV ² 10.5	Qty.	Description Moldboard Assembly
	09329	09217	09446	09226	09447	09237	1	R.H. & L.H. Wing
1	09328	09208	09442	09212	09444	09280	1	• R.H. Wing
2	09327	09209	09443	09213	09445	09279	1	• L.H. Wing
3	13200	12540	13923	12568	13924	13081	2	•• Trip Edge Weld 1/2" Holes
3	-----	14195	14170	14196	14180	14151	2	•• Trip Edge Weld 5/8" Holes
4	22438	22438	22438	22438	22438	22438	8	•• 1 X 2-1/2" Pin
5	20420	20420	20420	20420	20420	20420	8	•• 1/4 x 2" Cotter Pin
6	13205	12528	84285	12528	84285	12528	2	•• T -Bar Weldment
7	12978	07215	07215	07215	07215	07215	4	•• Trip Spring
8	20145	20145	20145	20145	20145	20145	2	•• Bolt H 5/8-11 x 3" Gr. 5
9	20318	20318	20318	20318	20318	20318	2	•• Locknut 5/8-11
10	20357	20357	20357	20357	20357	20357	4	•• Flatwasher 5/8
11	09124	09124	09124	09124	09124	09124	4	•• Eyebolt w/Locknuts and Cap
	09112	09218	09218	09219	09219	09110	1	Cutting Edge Kit 1/2" Bolt
12	09331	09210	09210	09211	09211	09111	2	• Cutting Edge
	08222	08222	08222	08222	08222	08222	1	• Hardware Bag
13	20307	20307	20307	20307	20307	20307	11	•• Locknut 1/2-13
14	21961	21961	21961	21961	21961	21961	9	•• Bolt C 1/2-13 x 2"
18	22066	22066	22066	22066	22066	22066	2	•• Bolt C 1/2-13 x 2-3/4" Gr.5
	09332	09229	09229	09229	09229	09229	1	• Bottom Belt Kit 1/2" Bolt
** 15	13208	12538	12538	12538	12538	12538	1	•• Bottom Belt
	08261	08131	08131	08131	08131	08131	1	•• Hardware Bag
* 16	13209	12549	12549	12549	12549	12549	2	••• Backing Plate
* 17	20307	20307	20307	20307	20307	20307	2	••• Locknut 1/2-13
* 18	22066	22066	22066	22066	22066	22066	2	••• Bolt C 1/2-13 x 2-3/4" Gr.5
	-----	09487	09487	09488	09488	09489	1	Cutting Edge Kit 5/8" Bolt
12	-----	09484	09484	09485	09485	09486	2	• Cutting Edge
	-----	08427	08427	08427	08427	08427	1	• Hardware Bag
13	-----	20309	20309	20309	20309	20309	14	•• Locknut 5/8-11
14	-----	8500002267	8500002267	8500002267	8500002267	8500002267	14	•• Bolt C 5/8-11 x 2"
	-----	09490	09490	09490	09490	09490	1	•• Bottom Belt Kit 5/8" Bolt
	-----	09490	09490	09490	09490	09490	1	• Bottom Belt Kit 5/8" Bolt
** 15	-----	14204	14204	14204	14204	14204	1	•• Bottom Belt
	-----	08428	08428	08428	08428	08428	1	•• Hardware Bag
* 16	-----	14205	14205	14205	14205	14205	2	••• Backing Plate
* 17	-----	20309	20309	20309	20309	20309	2	••• Locknut 5/8-11
* 18	-----	21962	21962	21962	21962	21962	2	••• Bolt C 5/8-11 x 2-3/4" Gr.5
	08144	08752	08752	08752	08752	08752	1	• Hardware Carton
** 19	13207	12557	12557	12557	12557	12557	1	•• Pivot Pin
* 20	20095	20095	20095	20095	20095	20095	1	•• Bolt H 1/2-13 x 1-1/2" Gr. 5
* 21	20329	20329	20329	20329	20329	20329	1	•• Lockwasher 1/2
**	08852	08852	08852	08852	08852	08852	1	•• Plow Marker Kit
22	81100095	81100095	81100095	81100095	81100095	81100095	2	••• Plow Marker
23	22249	22249	22249	22249	22249	22249	4	••• Locknut 1/4-20 SS
24	22250	22250	22250	22250	22250	22250	4	••• Bolt H 1/4-20 x 1" SS
	09339	09230	09230	09230	09230	09230	1	Top Deflector Kit
** 25	13323	12536	12536	12536	12536	12536	1	• Top Deflector
	08745	08745	08745	08745	08745	08745	1	• Hardware Bag
* 26	13724	13724	13724	13724	13724	13724	1	•• Deflector Brace
* 27	20028	20028	20028	20028	20028	20028	7	•• Bolt H 5/16-18 x 1-1/4" Gr. 2
* 28	20352	20352	20352	20352	20352	20352	7	•• Flatwasher 5/16
* 29	20304	20304	20304	20304	20304	20304	7	•• Locknut 5/16-18
30	13855	13755	13755	13755	13755	13755	1	A-Frame

Parts indented are included in the carton, bag or assembly under which they are indented.

- * (SV & SV²) Items in 08660 Hardware Bag included in 08752
- * (SVLD) Items in 08260 Hardware Bag included in 08144
- ** (SV & SV²) Items packed in the 08752 Hardware Carton
- ** (SVLD) Items packed in the 08144 Hardware Carton

OPTIONAL MUSHROOM RUNNERS - FIGURE 2
PARTS LIST

Item	Part No.	Qty	Description
1	09214	1	Super-V Mushroom Runner Kit
2	12394	2	• Mushroom Shoe Casting Assy.
3	12449	2	• Runner Spacer
4	20363	22	• Runner Washer
5	22083	2	• Linch Pin
6	12545	2	• Runner Bracket Assy.
7	08585	1	• Hardware Bag
8	20164	4	• Bolt H 5/8-11 x 2" Gr. 5
9	20309	4	• Locknut 5/8-11

Reference Form 1-884 for Installation Instructions

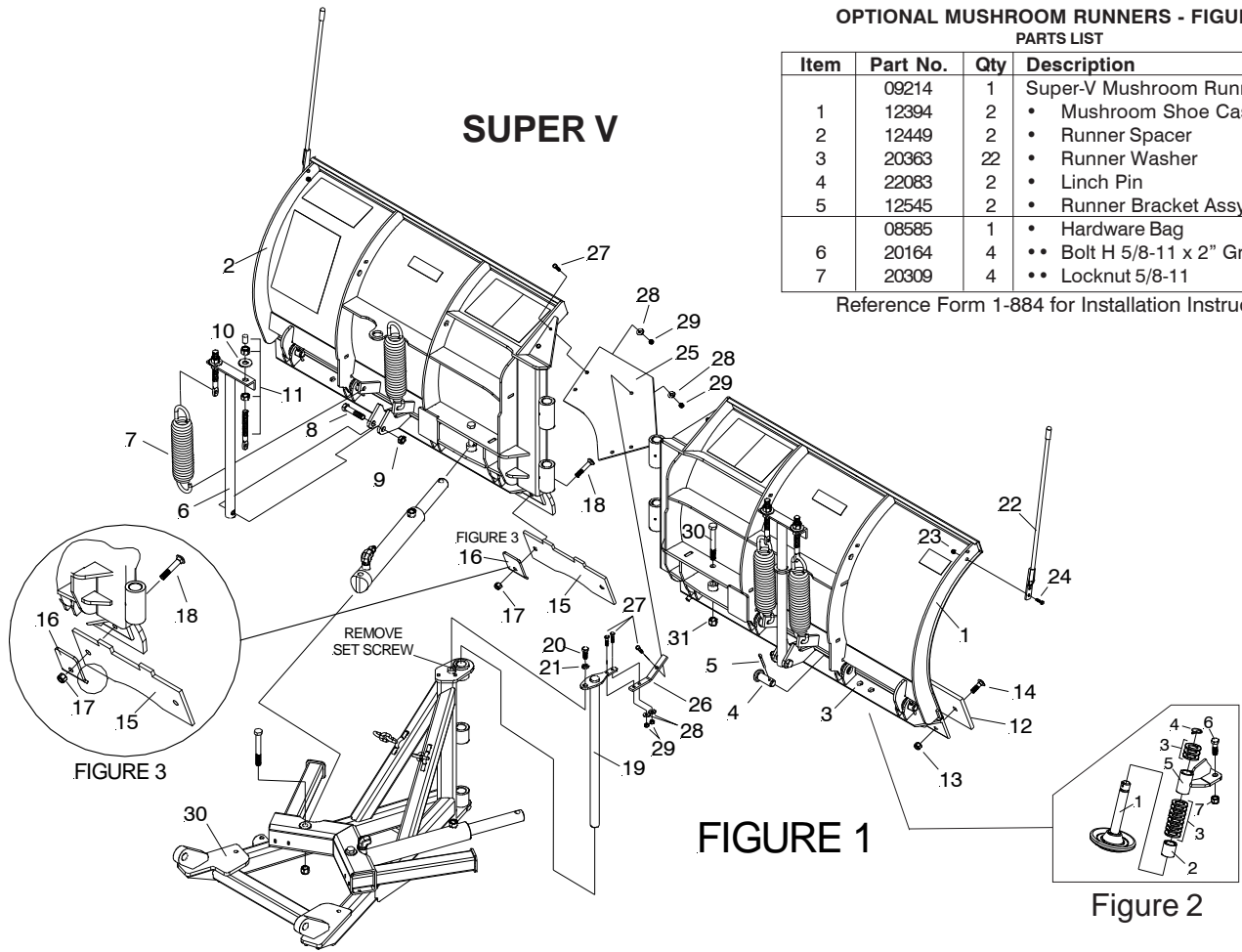

SUPER V²

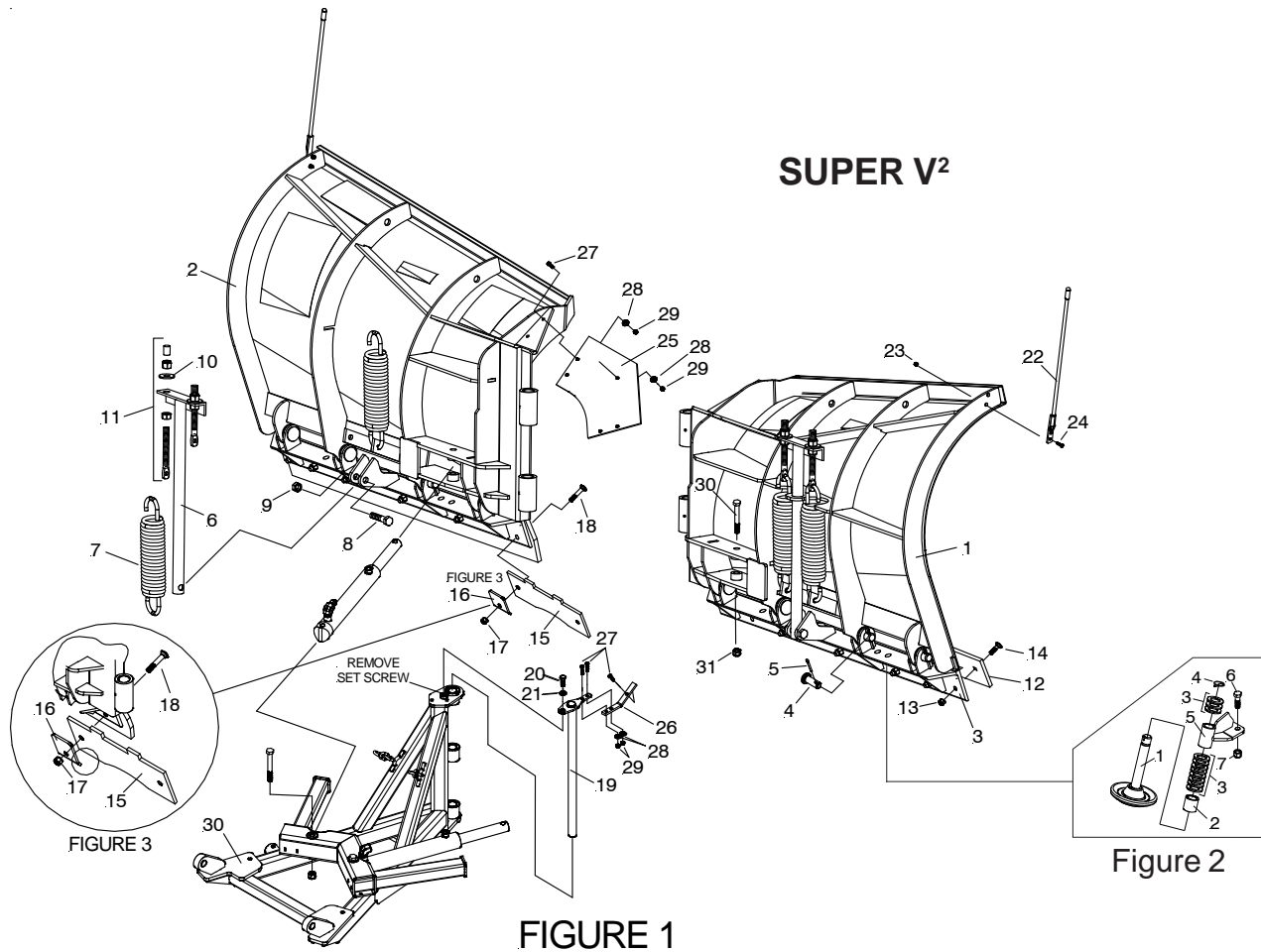

INSTALLATION INSTRUCTIONS:

FIGURE 1

1. Position wing assemblies 1 & 2 face down on cardboard as not to damage the painted surfaces. Grease the bushings on both left and right wings. Position the wings so pivot bushings align. Note: Cutting Edges will be inline at this time.
2. Remove 1/2"-13 x 1" set screw located in top of A-Frame (30) tower. Grease A-Frame (30) bushings and Pivot Pin (19). With a helper, lift the A-Frame (30) and insert its bushings in alignment with the wing bushings.
3. Insert Pivot Pin (19) through bushings. Install and tighten 1/2" x 1.50" bolt (20) and 1/2" lockwasher (21) to top of A-Frame holding Pivot Pin (19) in place. Note: Wipe off any excess grease at this time.
4. Using the A-Frame as leverage tilt the moldboard assembly raising the Cutting Edges off the ground. Support Cutting Edges (12) 5 to 6 inches off the ground.
5. Install the Bottom Belt (15) to left and right wing at Tripedge (3) using 1/2" x 2.75" carriage bolt (18) and locknut (17). Note: Be sure that Belt (15) folds are upward and notches are toward the A-Frame (30). Assemble Backing Plate (16) so bent end is facing the cutting edge forcing the belt against the Tripedge (3). See Figure 3.
6. Using the A-Frame as leverage tilt the moldboard assembly raising the Cutting Edges off the supports. Remove supports and set moldboard assembly to the upright position.
7. Assemble Snow Deflector Brace (26) to Pivot Pin (19). Place brace under the pivot pin plate. Attach using two 5/16" x 1-1/4" bolts (27), 5/16 washers (28) and 5/16 locknuts (29).
8. Position moldboard assembly in the "Vee" position.
9. Assemble Top Snow Deflector (25) positioning the deflector under deflector brace (26). Attach deflector ends under left and right wing gussets using 5/16" x 1-1/4" bolts (27), 5/16 locknuts (29) and 5/16 washers (28). Tighten locknuts such that washers slightly compress the rubber surface.
Note: Snow Deflector Belt should fold/loop downward between brace and each wing gusset when wings are not in the "Vee" position.

See Hydraulic Instructions (Form 1-883) for assembly of Wing Cylinders.

CAUTION: CHECK THE TRIPEDGE ADJUSTMENT AT THIS TIME.

- A. THE SPRINGS ARE PROPERLY ADJUSTED WHEN A PIECE OF PAPER CAN BE PLACED BETWEEN EACH COIL.
- B. IF THE TRIPEDGE SPRINGS NEED ADJUSTMENT, LOOSEN THE BOTTOM NUT (A) ON BOTH SPRING ASSEMBLIES. ROTATE THE TOP LOCKNUT NUT (B) UNTIL THE SPRINGS ARE PROPERLY ADJUSTED.
- C. BE SURE TO TIGHTEN THE BOTTOM NUT (A) SECURELY ON BOTH ASSEMBLIES TO PREVENT LOOSENING OF THE ASSEMBLIES.

Spring Assembly

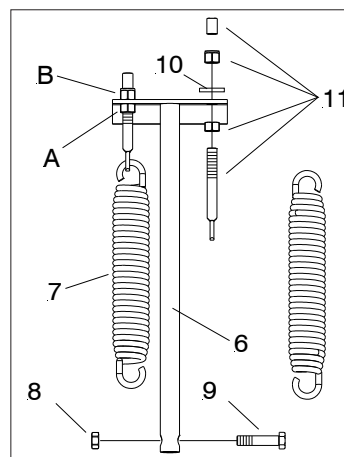

Parts & Installation Instructions

Stainless Steel SV² 8.5, 9.5 & 10.5

PARTS LIST

Item	Part No. SV ² 8.5	Part No. SV ² 9.5	Part No. SV ² 10.5	Qty.	Description
	09494	09495	09496	1	Moldboard Assembly
	09466	09470	09476	1	• SS R.H. Wing
	09467	09471	09477	1	• SS L.H. Wing
1	14055	14057	14129	1	•• RH Moldboard Weld
2	14056	14058	14130	1	•• LH Moldboard Weld
3	14059	14063	14131	1	•• RH Stainless Steel Sheet
4	14060	14064	14132	1	•• LH Stainless Steel Sheet
5	14098	14118	14150	2	•• Bottom Mount Plate
6	14170	14180	14151	2	•• Trip Edge Weld
7	20307	20307	20307	10	•• Locknut 1/2-13
8	20309	20309	20309	12	•• Locknut 5/8-11
9	21262	21262	21262	8	•• Flatwasher 1" SAE
10	21943	21943	21943	10	•• Bolt C 1/2-13 x 1-3/4"
11	22438	22438	22438	8	•• 1 X 2-1/2" Pin
12	22945	22945	22945	8	•• Roll Pin 5/16 x 1.5"
13	84285	84285	12528	2	•• T -Bar Weldment
14	07215	07215	07215	4	•• Trip Spring
15	20145	20145	20145	2	•• Bolt H 5/8-11 x 3" Gr. 5
16	20318	20318	20318	2	•• Locknut 5/8-11
17	20357	20357	20357	4	•• Flatwasher 5/8
18	09124	09124	09124	4	•• Eyebolt w/Locknuts and Cap
	09487	09488	09489	1	Cutting Edge Kit
19	09484	09485	09486	2	• Cutting Edge
	08427	08427	08427	1	• Hardware Bag
20	20309	20309	20309	14	•• Locknut 5/8-11
21	8500002267	8500002267	8500002267	14	•• Bolt C 5/8-11 x 2"
22	09490	09490	09490	1	•• Bottom Belt Kit
	09490	09490	09490	1	• Bottom Belt Kit
** 23	14204	14204	14204	1	•• Bottom Belt
	08428	08428	08428	1	•• Hardware Bag
* 24	14205	14205	14205	2	••• Backing Plate
* 25	20309	20309	20309	2	••• Locknut 5/8-11
* 26	21962	21962	21962	2	••• Bolt C 5/8-11 x 2-3/4" Gr.5
	08752	08752	08752	1	• Hardware Carton
** 27	12557	12557	12557	1	•• Pivot Pin
* 28	20095	20095	20095	1	•• Bolt H 1/2-13 x 1-1/2" Gr. 5
* 29	20329	20329	20329	1	•• Lockwasher 1/2
**	08852	08852	08852	1	•• Plow Marker Kit
30	811000095	811000095	811000095	2	••• Plow Marker
31	22249	22249	22249	4	••• Locknut 1/4-20 SS
32	22250	22250	22250	4	••• Bolt H 1/4-20 x 1" SS
	09230	09230	09230	1	Top Deflector Kit
** 33	12536	12536	12536	1	• Top Deflector
	08745	08745	08745	1	• Hardware Bag
* 34	13724	13724	13724	1	•• Deflector Brace
* 35	20028	20028	20028	7	•• Bolt H 5/16-18 x 1-1/4" Gr. 2
* 36	20352	20352	20352	7	•• Flatwasher 5/16
* 37	20304	20304	20304	7	•• Locknut 5/16-18
38	13755	13755	13755	1	A-Frame

Parts indented are included in the carton, bag or assembly under which they are indented.

* (SV²) Items in 08660 Hardware Bag included in 08752

** (SV²) Items packed in the 08752 Hardware Carton

STAINLESS STEEL SUPER V²

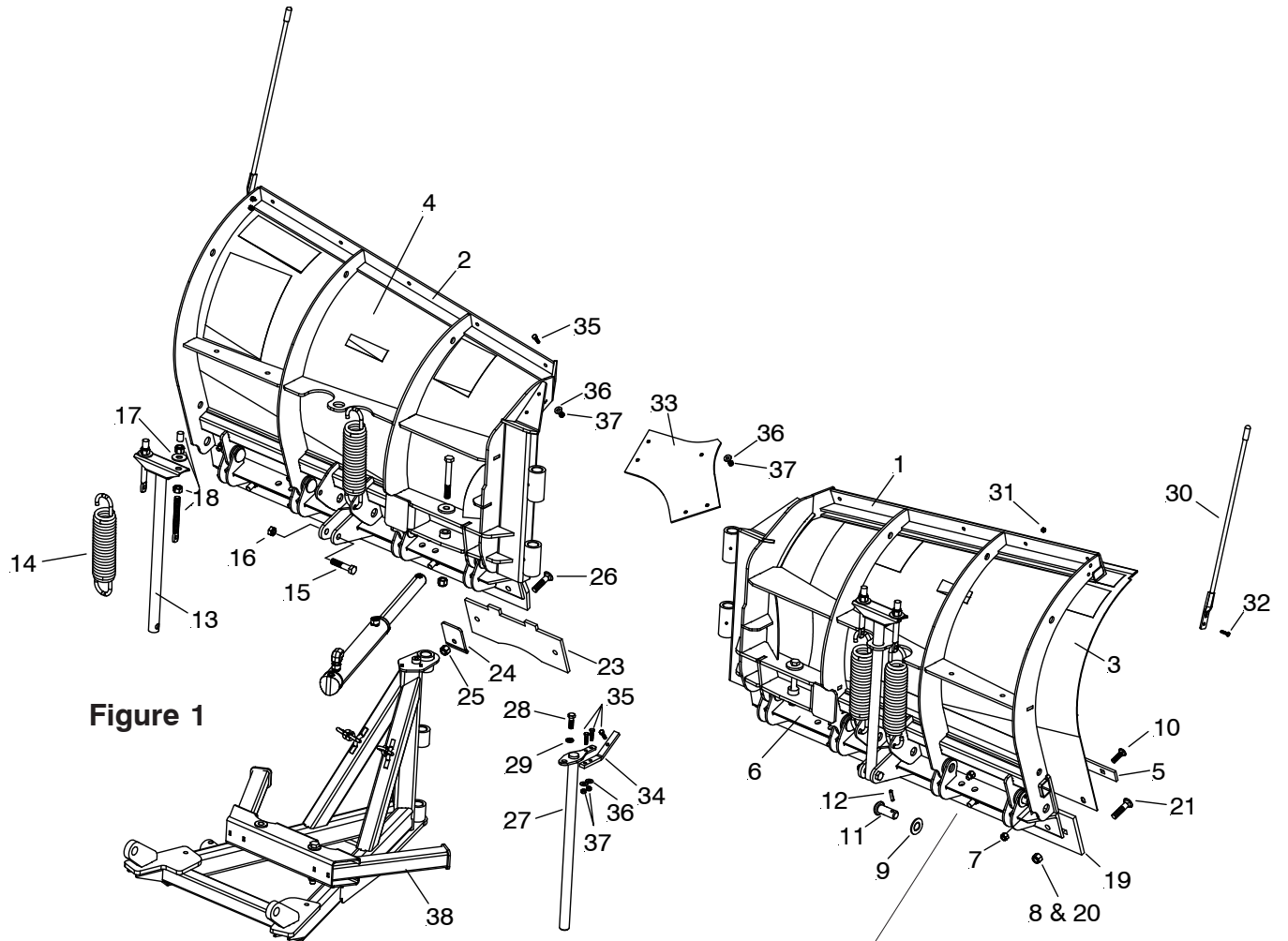

Figure 1

OPTIONAL MUSHROOM RUNNERS - FIGURE 2

PARTS LIST

Item	Part No.	Qty	Description
	09214	1	Super-V Mushroom Runner Kit
1	12394	2	• Mushroom Shoe Casting Assy.
2	12449	2	• Runner Spacer
3	20363	22	• Runner Washer
4	22083	2	• Linch Pin
5	12545	2	• Runner Bracket Assy.
	08585	1	• Hardware Bag
6	20164	4	• Bolt H 5/8-11 x 2" Gr. 5
7	20309	4	• Locknut 5/8-11

Reference Form 1-884 for Installation Instructions

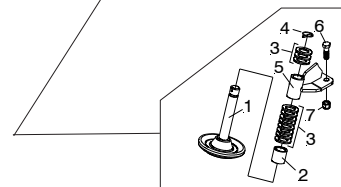

Figure 2

STAINLESS STEEL SV² INSTALLATION INSTRUCTIONS:

FIGURE 1

1. Position wing assemblies 1 & 2 face down on cardboard as not to damage the painted surfaces. Grease the bushings on both left and right wings. Position the wings so pivot bushings align. Note: Cutting Edges will be inline at this time.
2. Remove 1/2"-13 x 1" set screw located in top of A-Frame (38) tower. Grease A-Frame (38) bushings and Pivot Pin (27). With a helper, lift the A-Frame (38) and insert its bushings in alignment with the wing bushings.
3. Insert Pivot Pin (27) through bushings. Install and tighten 1/2" x 1.50" bolt (28) and 1/2" lockwasher (29) to top of A-Frame holding Pivot Pin (27) in place. Note: Wipe off any excess grease at this time.
4. Using the A-Frame as leverage tilt the moldboard assembly raising the Cutting Edges off the ground. Support Cutting Edges (19) 5 to 6 inches off the ground.
5. Install the Bottom Belt (23) to left and right wing at Tripedge (6) using 1/2" x 2.75" carriage bolt (26) and locknut (25). Note: Be sure that Belt (23) folds are upward and notches are toward the A-Frame (38). Assemble Backing Plate (24) so bent end is facing the cutting edge forcing the belt against the Tripedge (6).
6. Using the A-Frame as leverage tilt the moldboard assembly raising the Cutting Edges off the supports. Remove supports and set moldboard assembly to the upright position.
7. Assemble Snow Deflector Brace (34) to Pivot Pin (27). Place brace under the pivot pin plate. Attach using two 5/16" x 1-1/4" bolts (35), 5/16 washers (36) and 5/16 locknuts (37).
8. Position moldboard assembly in the "Vee" position.
9. Assemble Top Snow Deflector (33) positioning the deflector under deflector brace (34). Attach deflector ends under left and right wing gussets using 5/16" x 1-1/4" bolts (35), 5/16 locknuts (36) and 5/16 washers (37). Tighten locknuts such that washers slightly compress the rubber surface.
Note: Snow Deflector Belt should fold/loop downward between brace and each wing gusset when wings are not in the "Vee" position.

See Hydraulic Instructions (Form 1-883) for assembly of Wing Cylinders.

CAUTION: CHECK THE TRIPEDGE ADJUSTMENT AT THIS TIME.

- A. THE SPRINGS ARE PROPERLY ADJUSTED WHEN A PIECE OF PAPER CAN BE PLACED BETWEEN EACH COIL.
- B. IF THE TRIPEDGE SPRINGS NEED ADJUSTMENT, LOOSEN THE BOTTOM NUT (A) ON BOTH SPRING ASSEMBLIES. ROTATE THE TOP LOCKNUT NUT (B) UNTIL THE SPRINGS ARE PROPERLY ADJUSTED.
- C. BE SURE TO TIGHTEN THE BOTTOM NUT (A) SECURELY ON BOTH ASSEMBLIES TO PREVENT LOOSENING OF THE ASSEMBLIES.

Spring Assembly

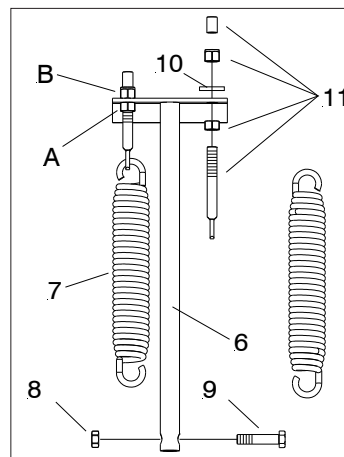

Meyer Products LLC reserves the right, under its continuing product improvement program, to change construction or design details, specifications and prices without notice or without incurring any obligation.