



**Assembly
&
Installation Instructions**
FOR
SUBFRAME COMPONENTS PACKAGE 99100578
AND
SUBFRAME NOSE PIECE PACKAGE 96106046

TO FIT
1995 - LATER TOYOTA TACOMA 4x4
1996 - LATER TOYOTA 4 RUNNER 4x4



1. THINK SAFETY, ALWAYS WEAR SAFETY GLASSES WHEN PERFORMING THE OPERATIONS PRESCRIBED IN THESE INSTRUCTIONS
2. READ ALL INSTRUCTIONS CAREFULLY BEFORE ATTEMPTING INSTALLATION
3. BEFORE BEGINNING WORK MAKE SURE TO SET PARKING BRAKE AND CHOCK WHEELS



MINIMUM VEHICLE RECOMMENDATIONS

Heavy Duty Alternator Heavy Duty Battery
 Manufacturers Snow Plow Package

NOTE: On some vehicles it may be necessary to use a form of load booster to decrease the vehicle's front suspension sag with the snow plow in place. This can be accomplished with the use of supplementary air bags, booster springs, or similar load boosting devices. Since there are different load boosting devices available, it will up to the customer/end user to decide and purchase the product to suit the application, and not the responsibility of Sno-Way International, Inc.

ASSEMBLY TOOLS NEEDED

Drill Bits 1/4", 13/32"
 Impact Sockets 7/16" – 1-3/8"
 Impact Sockets Metric 10mm – 19mm
 Wrenches 7/16" – 1-3/8"
 Wrenches Metric 10mm – 19mm
 Torque Wrench Hacksaw
 Center Punch and Hammer Alignment Pry Bar
 Clamping Device ("C" Clamp, Bar Clamp, type device...)

INSTALLATION NOTES

1. Unless otherwise specified, mount all Sub-Frame Components to vehicle before tightening any hardware.
2. It is recommended that **LOCTITE®**, or similar thread locking product, be used on ALL mounting hardware (i.e. Nuts, Cap Screws, Bolts, etc.).
3. Vehicle should be parked on a level surface with a normal vehicle load on the FRONT suspension.
4. Items in parentheses () refer to quantity required for this step. Items in parentheses with a pound sign (#) indicate the part number as found in the parts list on page 4 of this document.
 Example: (2) 5/8" Flat Washers (#8) .
5. It maybe necessary to relocate license plate holder. Relocate under the driver's side headlight by drilling new holes in the bumper.

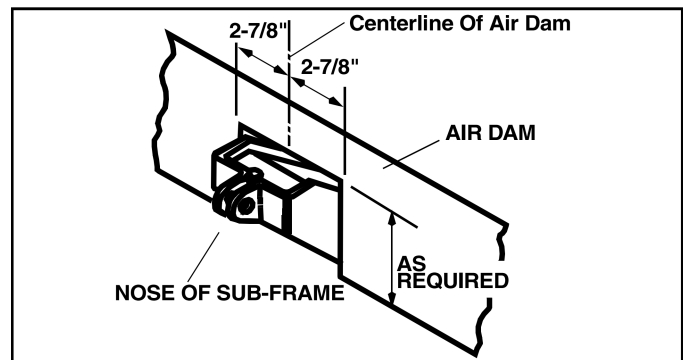

1. Remove splash guard and tow hook(s) if equipped. Retain, with mounting hardware, for future use if plow sub-frame is removed.
2. Align the slotted mounting holes in the Rear Mounting (#2) with existing holes centered in vehicle crossmember. Secure using (2) 1/2" x 4-1/2" Cap Screws (#6), (2) 5/8" Flat Washers (#8), (2) 1/2" Flat Washers (#7), and (2) 1/2" Nylock Nuts (#9).

MOUNTING INSTRUCTIONS

NOTE: The Bracket Assemblies, #3 and #4, are used in all applications covered in this manual. Their usage is different depending on model year, with the #3 Bracket Assembly used on the LH for applications 1995-96 to 1999, and on the RH for applications 1999 and later. The #4 Bracket Assembly is used on the RH for applications 1995-96 to 1999, and on the LH for applications 1999 and later. Refer to the Parts List drawings, if necessary, for clarification.

NOTE: Front air dam can be modified to clear Sub-Frame by cutting dam to allow clearance for nose of Sub-Frame. Cut air dam as shown and remove cut section or fold back for when nose piece is removed.

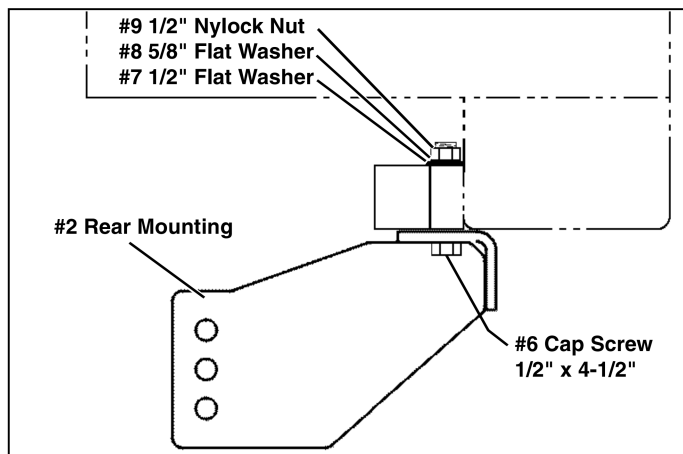

3. Mount the Bracket Assemblies (#3 and #4).
 - For vehicles 1995-96 to 1999: Bracket Assembly #3 is LH, Bracket Assembly #4 is RH for these applications. Position Bracket Assemblies so that the two larger holes in the top lip of the brackets are

toward the front and aligned with the tow hook holes in the vehicle frame. Secure brackets to frame using (4) M12-1.25 x 40mm Cap Screws (#10).

- For vehicles 1999 and later: Bracket Assembly #4 is LH, Bracket Assembly #3 is RH for these applications. Position Bracket Assemblies so that the two larger holes in the top lip of the brackets are toward the rear and aligned with the tow hook holes in the vehicle frame. Secure brackets to frame using (4) M12-1.25 x 40mm Cap Screws (#10). Using the front (smaller) hole in the top lip of the brackets as a template, center punch and drill a 13/32" hole through the vehicle frame on each side. Insert a 3/8" X 4-1/2" Cap Screw into the drilled hole from the bottom up through the LH bracket, place a Top Support Bracket (#14) on the Cap Screw on top of the frame as a backing plate, and secure using a 3/8" Nylock Nut (#13). Repeat procedure for the RH bracket.

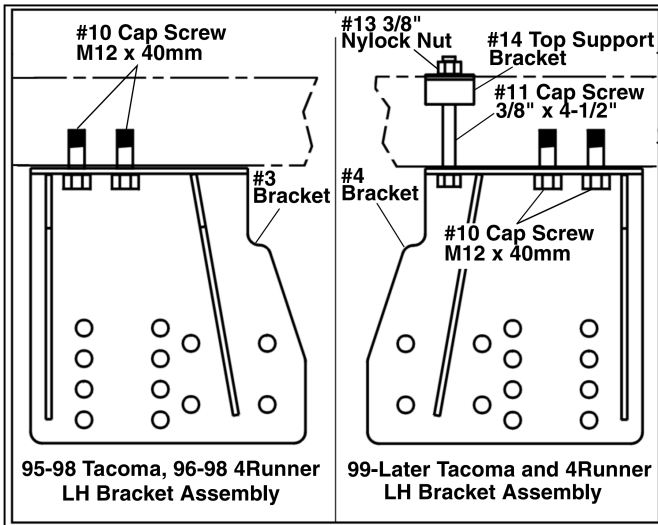

- Secure the Mounting Assembly (#1) to the Bracket Assemblies (#3 and #4) using (8) 1/2" x 1-1/2" Cap Screws (#5) and (6) 1/2" Nylock Nuts (#9). Use (1) 1/2" Lock Washer (#12) under the head of each of the two cap screws that install into threaded holes in the Mounting Assembly.

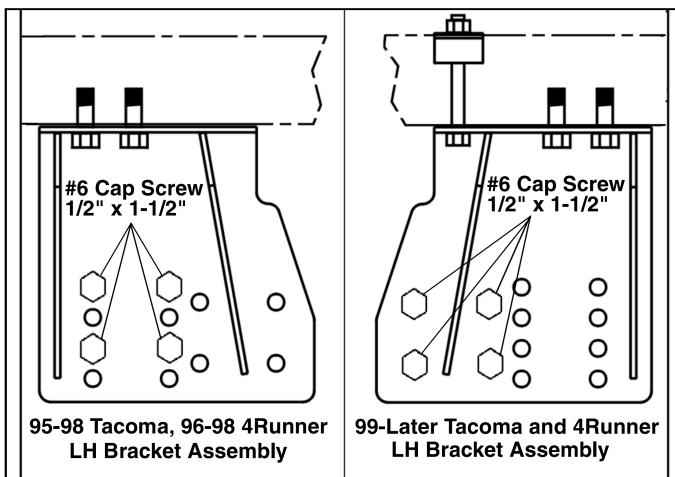

IMPORTANT: Height from the center of the lower Plow Mounting holes on the Sub-Frame to the ground should be between 9" and 11" to insure proper operation.

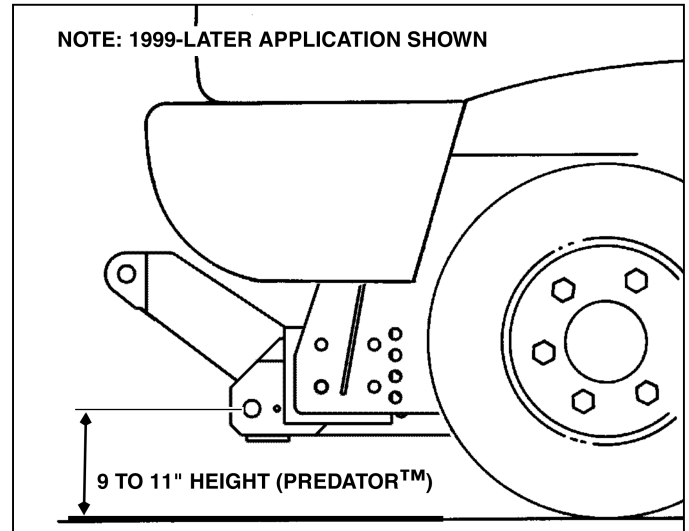

- Secure the Mounting Assembly (#1) to the Rear Mounting (#2) using (4) 1/2" x 1-1/2" Cap Screws (#5) and (4) 1/2" Nylock Nuts (#9).
- Using the Torque Specification Chart provided, torque all mounting hardware to their required specification. (See INSTALLATION NOTES 1 & 2.)

TORQUE SPECIFICATIONS FOR STANDARD MACHINE HARDWARE					
Bolt Size	GR.2 Dry	GR.5 Dry	GR.8 Dry	Metric Size	GR.8.8 Dry
1/4"	66*	9	12	M8	17
5/16"	11	17	25	M10	35
3/8"	20	30	45	M12	60
7/16"	32	50	70	M14	95
1/2"	50	75	110	M16	155
9/16"	70	110	150		
5/8"	100	150	220		
3/4"	175	260	380		
7/8"	170	430	600		
1"	250	640	900		

Note: These torque values are to be used for all hardware. Unless otherwise specified, all torque values must meet this specification.
 Note: All torque values are in Ft.-Lbs unless otherwise stated
 Note: *In-Lbs

REMEMBER After 5 to 10 hours of snowplow usage, re-torque all Cap Screws!

PARTS LIST

**FOR: 95-98 Tacoma
96-98 4 Runner**

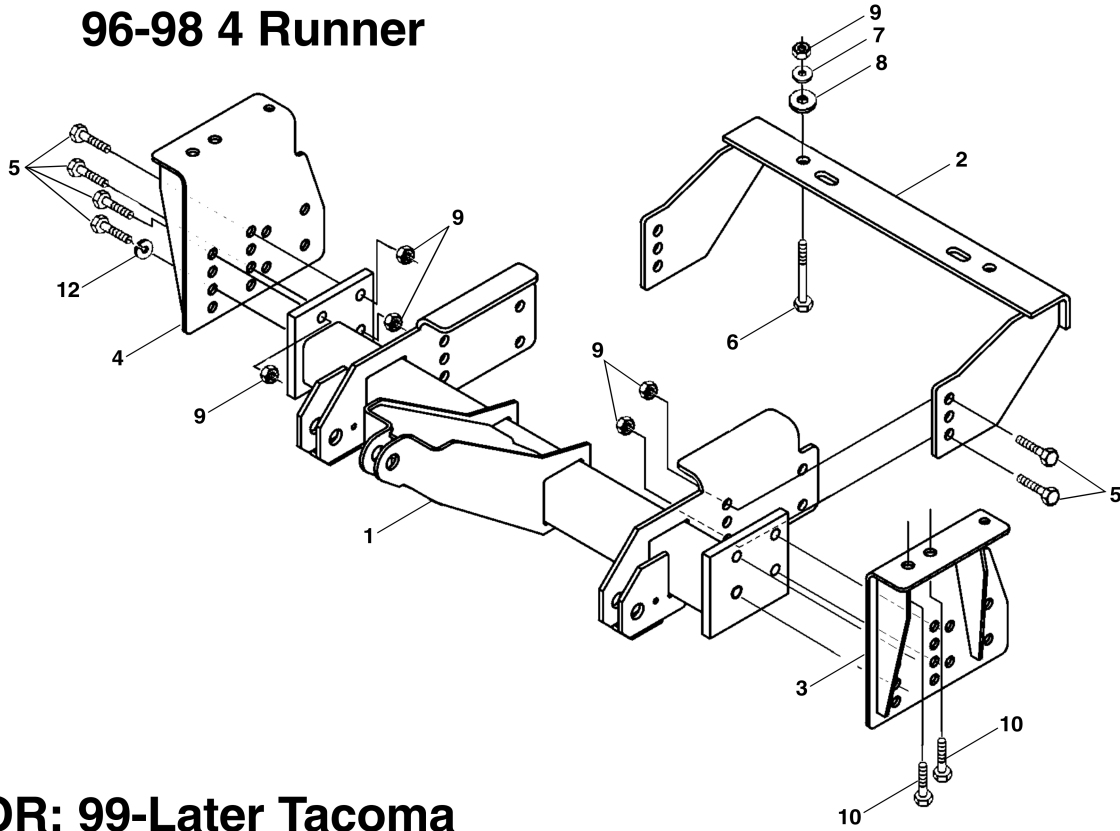

**FOR: 99-Later Tacoma
99-Later 4 Runner**

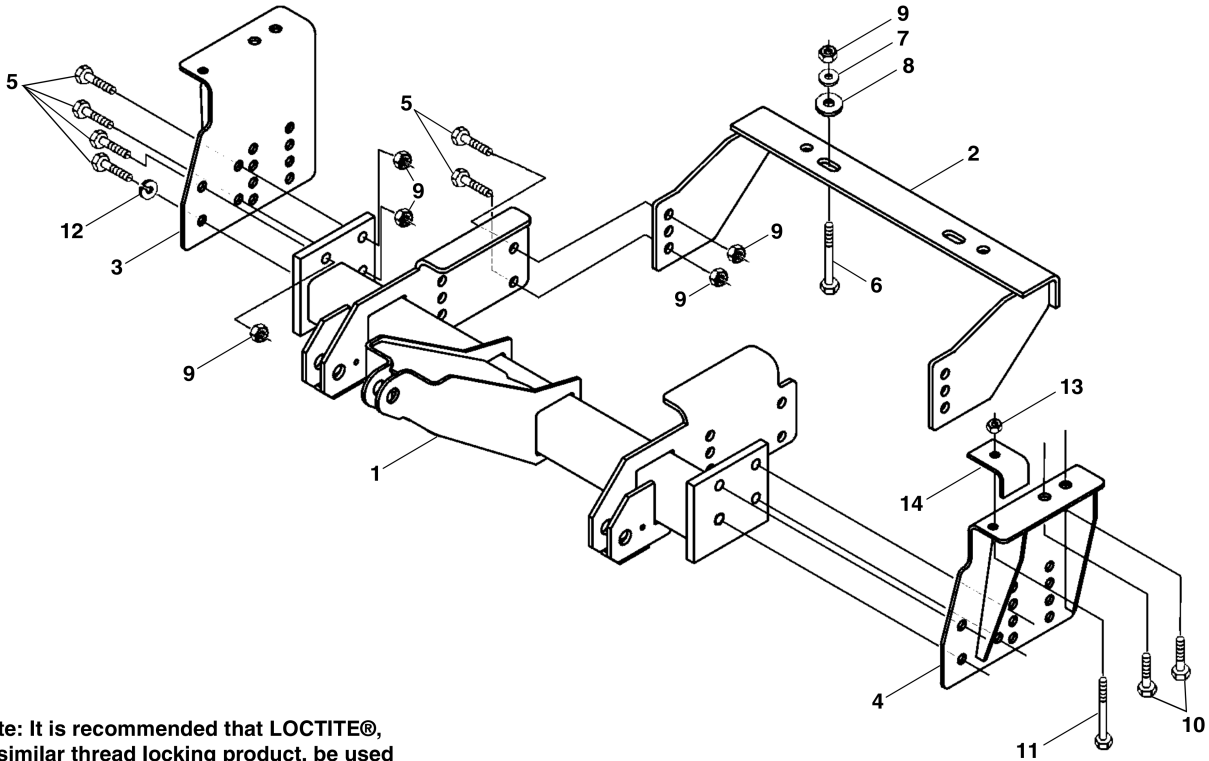

Note: It is recommended that LOCTITE®, or similar thread locking product, be used on ALL mounting hardware. (i.e. Nuts, Cap Screws, Bolts, etc.).

USING THIS PARTS LIST

Below is parts listing with four columns. The first column is the "ITEM", the second is the "PART NUMBER", The third is the "DESCRIPTION" and the fourth is the "QUANTITY".

The "**ITEM**" is the number used in the corresponding illustration.

The "**PART NO.**" is the number used to order replacement parts. If a number does not appear in the column the part is only available by ordering the complete assembly.

The "**DESCRIPTION**" is the name of the replacement part. At times the name may be indented, this means that the indented parts are part of the preceding assembly.

The "**QTY.**" is the quantity needed to service the assembly illustrated, not the complete product.

PARTS LIST

ITEM	PART NO.	DESCRIPTION	QTY.
1	96106046	Assembly, Mounting	1
2	96106064	Mounting, Rear	1
3	96106060	Bracket, Assembly (95-96 to 99, LH)(99-Later, RH).....	1
4	96106061	Bracket, Assembly (95-96 to 99, RH)(99-Later, LH).....	1
5	98009010	Cap Screw, Hex, 1/2"-13 x 1-1/2"	12
6	98009055	Cap Screw, Hex, 1/2"-13 x 4-1/2"	2
7	98009011	Washer, Flat, 1/2"	2
8	98009039	Washer, Flat, 5/8"	2
9	98009013	Nut, Hex, Nylock, 1/2"-13	12
10	98009054	Cap Screw, Hex, M12-1.25 x 40 mm	4
11	98100289	Cap Screw, Hex, 3/8"-16 x 4-1/2"	2
12	98009012	Washer, Lock , 1/2"	2
13	98009009	Nut, Hex, Nylock, 3/8"-16	2
14	96106066	Bracket, Top Support.....	2

SNO-WAY® INTERNATIONAL, INC.



Hartford, WI 53027 USA
Website: www.snoway.com
©2003 Sno-Way® International