

PARTS & INSTALLATION INSTRUCTIONS E-70 ELECTRO-LIFT® UNIT

PARTS LIST

ITEM	E-70 12V	E-70 24V	QTY	DESCRIPTION
	15826	16001	1	Lift Assembly (Unit Only)
1	15061	15061	1	• Base Assembly
2	15069	15061	1	• Cover Valve Block
3	15070	15135	1	• Motor - 12 Volt (2 Terminal)
4	15062	15062	1	• Pump Assy.
5	15083	15083	4	• Allen Head 1/4-20 x 3"
6	15063	15063	1	• Suction Tube 1/2" NPT
7	15064	15064	1	• Pump Filter Assy.
8	-----	-----	1	• Pipe Nipple 3/8 x 5-1/2" NPT
9	-----	-----	1	• Pipe Nipple 1/2 x 2" NPT
10	-----	-----	1	• Suction Tube 3/8" NPT
11	-----	-----	1	• 90 Degree Elbow 3/8 x 3/8 NPT
12	-----	-----	1	• 90 Degree Elbow 1/2 x 1/2 NPT
13	15065	15065	1	• Reservoir
14	15066	15066	1	• Reservoir Clamp
15	15067	15067	1	• Reservoir Breather Plug
16	15084	15084	6	• Allen Head 1/4-20 x 3-3/4"
17	15082	15082	1	• Complete Seal Kit

ITEM	E-70 12V	E-70 24V	QTY	DESCRIPTION
18	15068	15151	1	• Valve Block Assy.(12V)
	15085	15136	1	•• "A" Solenoid Assembly
19	15078	15137	1	••• "A" Coil (12V) (Black Wire)
20	15074	15074	1	••• "A" Cartridge Valve
	15086	15138	1	•• "B" Solenoid Assembly
21	15079	15139	1	••• "B" Coil (12V) (Redc Wire)
22	15075	15075	1	••• "B" Cartridge Valve
	15087	15140	1	•• "C" Solenoid Assembly
23	15080	15141	1	••• "C" Coil (12V) (Green Wire)
24	15081	15081	1	••• "C" Cartridge Valve
25	15071	15071	1	• Dual Port Check Valve Cartridge
26	15073	15073	1	• Check Valve Cartridge (15 PSI)
27	15076	15076	1	• Relief Valve
28	15077	15077	1	• Needle Valve Cartridge (Lower Adj.)

Parts indented are included in assembly under which they are indented.

Pump Relief Valve @ 1750 P.S.I. full flow. **Non Adjustable**
Cross-Over Relief Valve @ 2000 P.S.I. full flow. **Non Adjustable**

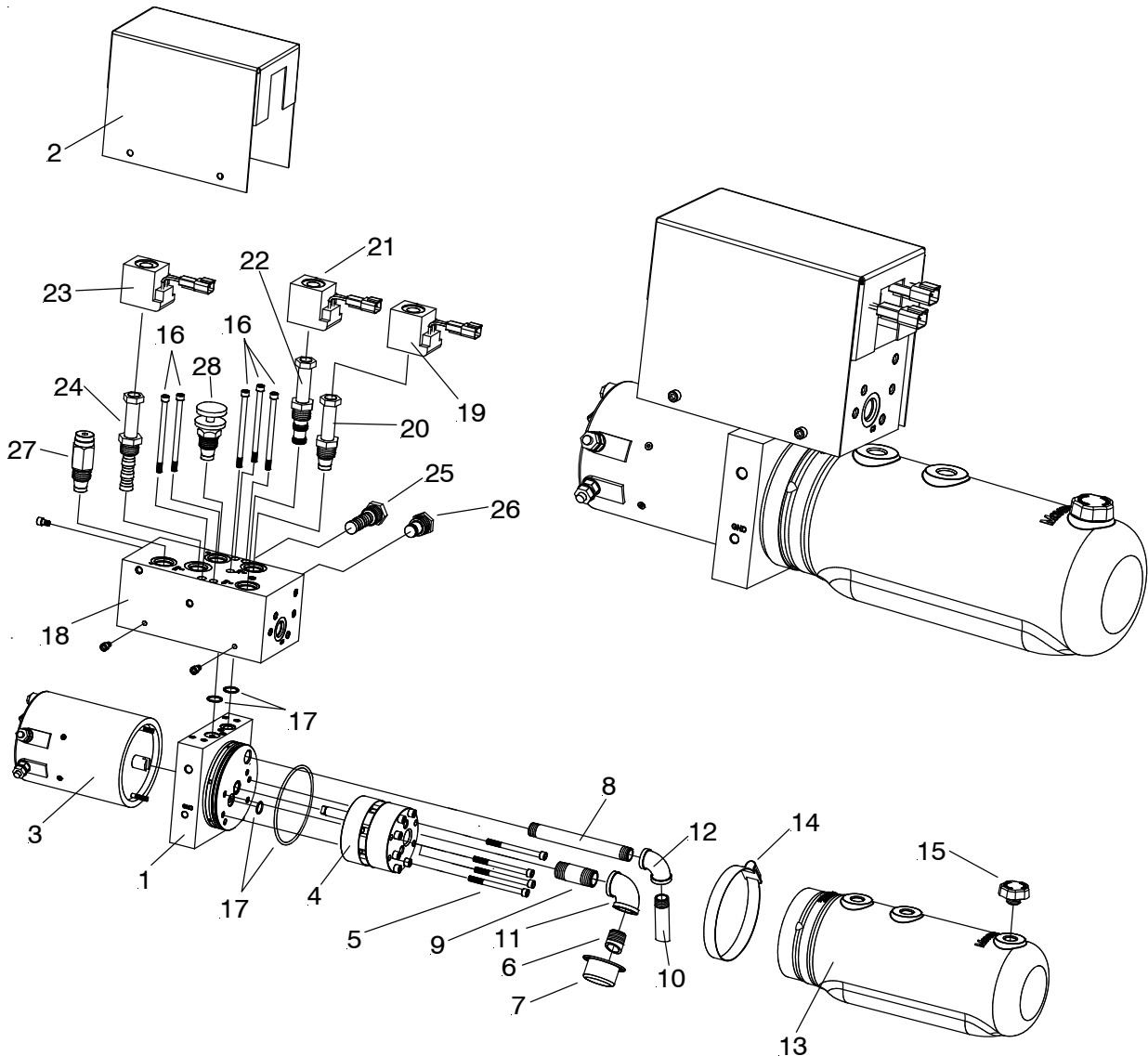

GENERAL INFORMATION

Before the Meyer Electro-Lift® unit is disassembled for repairs, make certain that all the maintenance procedures have been checked; refer to Owner's Manual. When the unit is to be overhauled, Master Seal Kit Part No. 15082 is required. This Kit contains all necessary Seals for rebuilding.

These instructions are intended as a guideline for overhaul of an E-70 Electro-Lift® unit.

When ordering parts, furnish Type of Unit, Part No., Name and Description.

More detailed information covering principles of Operation, Troubleshooting, Disassembly and Repair are found in the E-70 Electro-Lift® Service Manual. This is available for a nominal fee from your Meyer Distributor.

DISASSEMBLY AND INSPECTION OF UNIT

NOTE: DO NOT REUSE OLD O-RINGS.

Drain fluid from the unit by removing Reservoir Breather Plug (15). Carefully clamp E-70 unit firmly into vise.

1. Remove three 1/4-20 Allen Head Screws Cover (2) and remove.
2. Remove the hydraulic side harness (22692) from the hydraulic unit. **Note the positioning of the colored wires on the solenoid coil plugs to the coils on the hydraulic unit. (Reference Form 1-912)**
4. To disassemble MOTOR (3) from Base Assembly (1), loosen Motor mounting bolts, but DO NOT REMOVE bolts from motor housing.

Note: Motor end plate to be held in place. Temporarily install two 1/4-20 nuts on the motor mounting bolts to keep motor intact. Remove nuts when reinstalling Motor to pump.

5. To disassemble VALVE BLOCK (18) from BASE ASSEMBLY (1), remove Allen Head Screws (16).
6. To disassemble RESERVOIR (13) from BASE ASSEMBLY (1) loosen RESERVOIR CLAMP (14). Gently separate Reservoir (13) from Base Assembly (1).

SUBASSEMBLIES - INSPECTION

1. BASE ASSEMBLY (1)

- a) Check Base Assembly for cracks and damage.

2. MOTOR - Two Terminal (5)

Note: Complete Motor Assemblies are only available from Meyer Products. The only service part available is the Brush Kit 15854.

3. PUMP (7)

DO NOT at any time disassemble this Pump. This will void the warranty.

- a) Carefully remove fluid pick up piping (7-12).
- b) Clean Pump Filter Assy. (7)

4. RESERVOIR (13)

- a) Clean Reservoir (13) thoroughly.

5. VALVE BLOCK (18)

- a) Clean "A" Catridge (20) and inspect for damage. Replace O-rings from Seal Kit No. 15082.
- b) Clean "B" Catridge (22) and inspect for damage. Replace O-rings from Seal Kit No. 15082.
- c) Clean "C" Catridge (24) and inspect for damage. Replace O-rings from Seal Kit No. 15082.
- f) Test all Coils (19, 21 & 23) for electrical continuity. Nominal Coil resistance is 8.3 ohms.
- g) Remove Check Valves (25 & 26) from Valve Blocks (18) and inspect. Replace O-rings from Seal Kit No. 15082.
- h) Remove Relief Valve (27) and inspect for damage. Replace O-rings from Seal Kit No. 15082.
- i) Remove Needle Valve Cartridge (28) and inspect for damage. Clean before re-installing.
- j) With parts removed from Valve Block, clean and blow out with air to remove any foreign particles in Block.

6. UNIT REASSEMBLY

- a) Before reassembling, make certain all components and sub-assemblies are clean and free from all dirt and other foreign material.

Lubricate all orings with M-1 oil during assembly.

Coat all bolt threads with a anti-sieze lubricant prior to reassembly.

- b) Motor mounting bolts must be sealed with Permatex or an all weather type sealant.

- c) **USE NEW SEALS AND M-1 FLUID WHEN REASSEMBLING THE UNIT.**

- d) Proper fluid level is marked on the Reservoir (13) and should be checked with the lift cylinder fully retracted.

IMPORTANT: All Hydraulic Rams should be stored with a light coat of grease on chrome ram in the off season to prevent rust.

Meyer Products LLC reserves the right, under its continuing product improvement program, to change construction or design details, specifications and prices without notice or without incurring any obligation.

Meyer Products LLC
18513 Euclid Ave. • Cleveland, Ohio 44112-1084
Phone 486-1313 (Area Code 216)
www.meyerproducts.com • email info@meyerproducts.com



Meyer Products LLC
6 Angell Lane • Damariscotta, ME 04543-4507
Phone 563-2227 (Area Code 207)
www.meyerproducts.com • email info@meyerproducts.com