



**Assembly
&
Installation Instructions**

**FOR
SUBFRAME COMPONENTS PACKAGE 99100595
AND
SUBFRAME NOSE PIECE PACKAGE 96106406**

**TO FIT
2003- FORD EXPEDITION**



1. **THINK SAFETY, ALWAYS WEAR SAFETY GLASSES WHEN PERFORMING THE OPERATIONS PRESCRIBED IN THESE INSTRUCTIONS**
2. **READ ALL INSTRUCTIONS CAREFULLY BEFORE ATTEMPTING INSTALLATION**
3. **BEFORE BEGINNING WORK MAKE SURE TO SET PARKING BRAKE AND CHOCK WHEELS**



MINIMUM VEHICLE RECOMMENDATIONS

Heavy Duty Alternator
 Heavy Duty Battery
 Manufacturer's Snow Plow Package

ASSEMBLY TOOLS NEEDED

Drill Bits 1/4", 17/32"
 Impact Sockets 7/16" – 1-3/8"
 Wrenches 7/16" – 1-3/8"
 Torque Wrench
 Rat Tail Pry Bar
 Center Punch and Hammer
 Clamping Devices ("C", Bar, type device)
 Hacksaw

NOTE: On some vehicles it may be necessary to use a form of load booster to decrease the vehicle's front suspension sag with the snow plow in place. This can be accomplished with the use of supplementary air bags, booster springs, or similar load boosting devices. Since there are different load boosting devices available, it will up to the customer/end user to decide and purchase the product to suit the application, and not the responsibility of Sno-Way International, Inc.

INSTALLATION NOTES

1. Unless otherwise specified, mount all Sub-Frame Components to vehicle before tightening any hardware.
2. It is recommended that **LOCTITE®**, or similar thread locking product, be used on **ALL** mounting hardware (i.e. Nuts, Cap Screws, Bolts, etc.).
3. Vehicle should be parked on a level surface with a normal vehicle load on the FRONT suspension.
4. Items in parentheses () refer to quantity required for this step. Items in parentheses with a pound sign (#) indicate the part number as found in the parts list on the last page of this document.
 Example: (10) Washer, Lock, 1/2" (#8).
5. It maybe necessary to relocate license plate holder. Check state and local laws for placement, if needed.

MOUNTING INSTRUCTIONS

1. Remove the vehicle front bumper assembly. Retain hardware for reinstallation.
2. Remove air dam from bumper with hardware and retain for future use if sub-frame is removed.

NOTE: Front air dam can be modified to clear Sub-Frame by cutting dam to allow clearance for nose of Sub-Frame. Cut air dam as shown and remove cut section or fold back for when nose piece is removed.

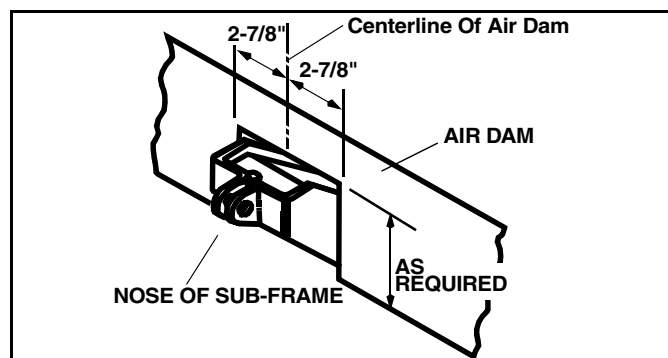

3. If equipped, remove tow hooks and hardware.
4. Install the Mounting Bracket, LH (#2) and the Mounting Bracket, RH (#3). Align the threaded holes in the bottom of the vehicle frame with the slots in the Mounting Brackets. Secure (two per side) using (4) M12-1.75 50 Cap Screws (#12), (4) 1/2" Flat Washers (#13) and (4) 1/2" Lock Washers. Secure the side holes on the Mounting Bracket, LH (#2) and RH (#3) with (4) Nut Plates (#6) inserted in the front of the frame, (4) 1/2"-13 x 1 1/2" Cap Screws (#8) and (4) 1/2" Lock Washers (#9).

NOTE: Note: the top, front hole in the vehicle frame may need to be enlarged/modified to accommodate the Mounting Brackets. Remember, all hardware at this point should be finger tight only.

5. Install the Mounting Assembly (#1). Secure to the Mounting Brackets, LH (#2) and RH (#3) using the front set of holes only. Secure using (4) 1/2"-13 x 1 1/2" Cap Screws (#8), (2) 1/2" Lock Washers (#9) (in the threaded holes) and (2) 1/2" Nylock Nuts (#10).
6. Install the Rear Mounting Bracket, LH (#4) and the Rear Mounting Bracket (#5). Align the bottom holes in the Rear Mounting Brackets with the rear holes in the Mounting Assembly and the side Mounting Brackets. Insert (4) 1/2"-13 x 2" Cap Screws (#11) and secure with (4) 1/2" Nylock Nuts (#10).

7. Align the Rear Mounting Bracket bottom hole with the existing slot in the vehicle frame, insuring the Rear Mounting Brackets are tight against the bottom of the vehicle frame and clamp in place. Using the top hole in the Rear Mounting Brackets as a template, center punch and drill a 1/4" pilot hole through the outside of the frame rail. Remove both Rear Mounting Brackets from the vehicle and Mounting Assembly. Drill out the 1/4" pilot holes with a 17/32" drill through the outside of the frame.
8. Secure the Rear Mounting Bracket and the Mounting Assembly as follows:
 - Reattach the Rear Mounting Brackets with the same hardware used in step #6.
 - Insert (4) Nut Plate Assemblies (#7) through the opening in the front of the vehicle frame, aligned with the top and bottom holes in each side. Secure with (4) 1/2"-13 x 1 1/2" Cap Screws (#8) and (4) 1/2" Lock Washers (#9).
9. Using the Torque Specification Chart provided, torque all cap screws.
10. Reinstall the bumper.

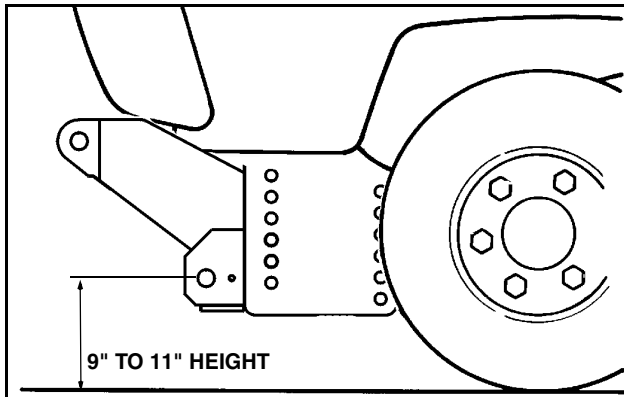

IMPORTANT: Height from the center of the lower Plow Mounting holes on the Sub-Frame to the ground should be between 9" and 11" to insure proper operation.

TORQUE SPECIFICATIONS FOR STANDARD MACHINE HARDWARE					
Bolt Size	GR.2 Dry	GR.5 Dry	GR.8 Dry	Metric Size	GR.8.8 Dry
1/4"	66*	9	12	M8	17
5/16"	11	17	25	M10	35
3/8"	20	30	45	M12	60
7/16"	32	50	70	M14	95
1/2"	50	75	110	M16	155
9/16"	70	110	150		
5/8"	100	150	220		
3/4"	175	260	380		
7/8"	170	430	600		
1"	250	640	900		

Note: These torque values are to be used for all hardware. Unless otherwise specified, all torque values must meet this specification.
 Note: All torque values are in Ft.-Lbs unless otherwise stated
 Note: *In-Lbs

REMEMBER After 5 to 10 hours of snowplow usage, re-torque all Cap Screws!

PARTS LIST

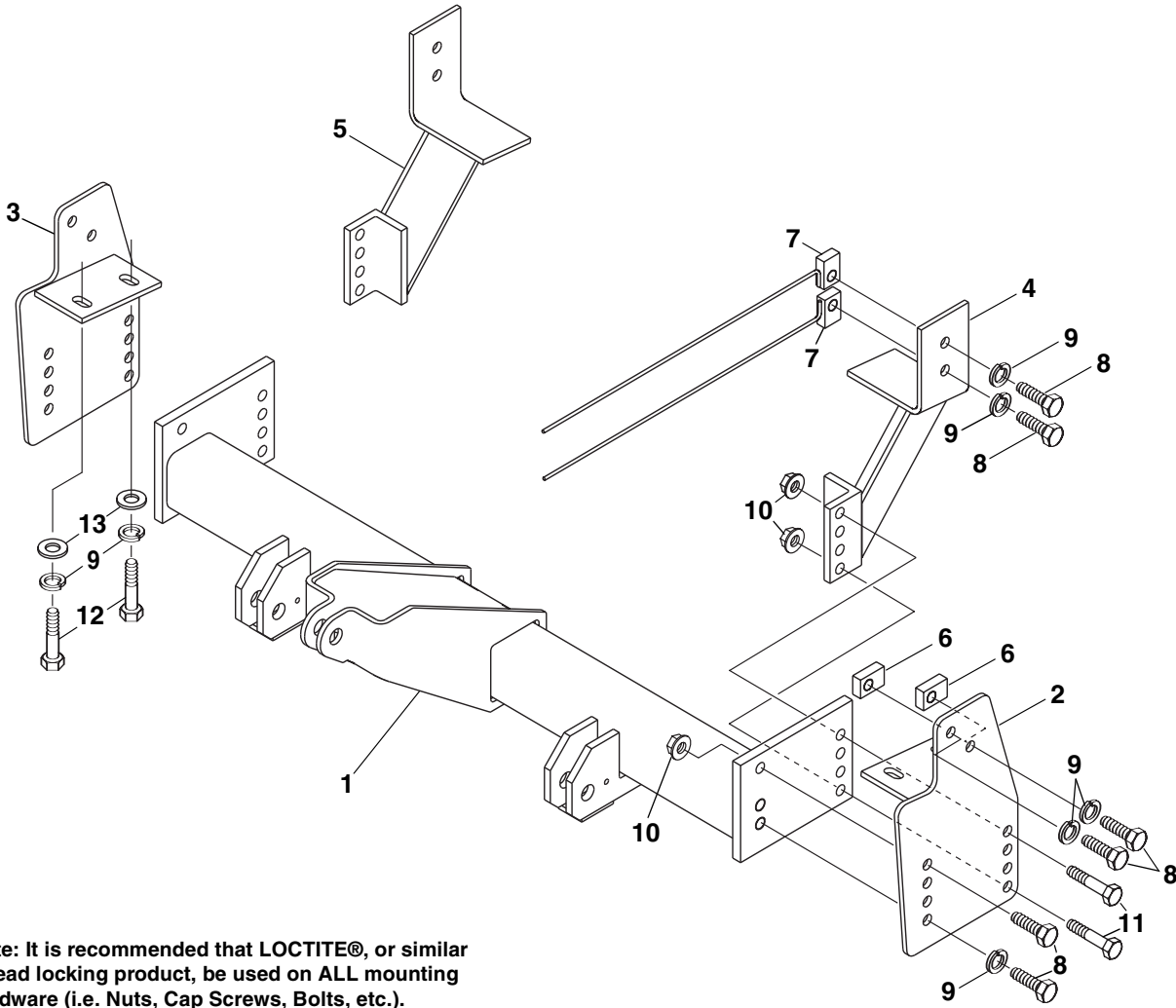

Note: It is recommended that LOCTITE®, or similar thread locking product, be used on ALL mounting hardware (i.e. Nuts, Cap Screws, Bolts, etc.).

ITEM	PART NO.	DESCRIPTION	QTY.
1	96106406	Assembly, Mounting	1
2	96106412	Bracket, Mounting, LH.....	1
3	96106413	Bracket, Mounting, RH	1
4	96106463	Bracket, Rear Mounting, LH	1
5	96106464	Bracket, Rear Mounting, RH	1
6	96103505	Plate, Nut	4
7	96103509	Plate, Nut Assembly	4
8	98009010	Cap Screw, Hex Head, 1/2"-13 x 1-1/2"	12
9	98009012	Washer, Lock, 1/2"	14
10	98009013	Nut, Hex, Nylock 1/2"-13	6
11	98100094	Cap Screw, Hex Head, 1/2"-13 x 2"	4
12	98100188	Cap Screw, Hex Head, M12-1.75 x 50mm	4
13	98009011	Washer, Flat, 1/2"	4

SNO-WAY® INTERNATIONAL, INC.



Hartford, WI 53027 USA
 Website: www.snoway.com
 ©2003 Sno-Way® International