

SNO-WAY[®]

SNOW & ICE CONTROL EQUIPMENT

Assembly & Installation Instructions

**FOR
SUBFRAME COMPONENTS PACKAGE 99100598
AND
SUBFRAME NOSE PIECE PACKAGE 96106597**

**TO FIT
1992 - 1998 Ford 4X4 F250 HD & F350 & F350 Chassis Cab**



1. **THINK SAFETY, ALWAYS WEAR SAFETY GLASSES WHEN PERFORMING THE OPERATIONS PRESCRIBED IN THESE INSTRUCTIONS**
2. **READ ALL INSTRUCTIONS CAREFULLY BEFORE ATTEMPTING INSTALLATION**
3. **BEFORE BEGINNING WORK MAKE SURE TO SET PARKING BRAKE AND CHOCK WHEELS**



MINIMUM VEHICLE RECOMMENDATIONS

Heavy Duty Front Springs
 Heavy Duty Battery
 Heavy Duty Alternator
 Manufacturer's Snow Plow Package

NOTE: On some vehicles it may be necessary to use a form of load booster to decrease the vehicle's front suspension sag with snow plow in place. This can be accomplished with the use of supplementary air bags, booster springs, or similar load boosting devices. Since there are different load boosting devices available, it will be up to the customer/end user to decide and purchase the product to suit the application, and not the responsibility of Sno-Way International, Inc.

NOTE: On some vehicles, the anti-sway bar must be removed in order to install the Subframe. Retain with hardware if the Subframe is removed from the vehicle. It is important that the anti-sway bar be re-installed if the Subframe is removed.

ASSEMBLY TOOLS NEEDED

Impact Sockets	7/16" – 1-3/8"
Metric Sockets	10 mm – 19 mm
Wrenches	7/16" – 1-3/8"
Metric Wrenches	10 mm – 19 mm
Drill Bits	1/4", 13/32" & 17/32"
Torque Wrench	
Center Punch	
Hammer	
Rat Tail Pry Bar	

INSTALLATION NOTES

1. **Unless otherwise specified, mount all Sub-Frame Components to vehicle before tightening any hardware.**
2. **It is recommended that LOCTITE®, or similar thread locking product, be used on ALL mounting hardware (i.e. Nuts, Cap Screws, Bolts, etc.).**
3. Vehicle should be parked on a level surface with a normal vehicle load on the FRONT suspension.
4. Items in parentheses () refer to quantity required for this step. Items in parentheses with a pound sign (#) indicate the part number as found in the parts list on the last page of this document.
 Example: (2) 5/8" x 1-1/2" Cap Screws (#9).
5. It may be necessary to relocate license plate holder. Check state and local laws for placement, if needed.

2. Insert (1) Assembly Bolt Plate (#19) inside the frame rail on both left and right hand sides. Install (1) Bracket, Left (#17) and (1) Bracket, Right (#18) using (2) 3/8" Flat Washers (#20) and (2) 3/8" Nylock Nuts (#21) on both sides of the frame.

NOTE: If mounting to slots, Push Front Crossmember forward to the front of the slots. It may be necessary to use (2) Shim Plates (#7) between the vehicle frame and the Front Crossmember.

3. From under vehicle frame, raise (1) Front Crossmember (#2) to align with existing holes (or slots) in vehicle frame. Secure using (2) 3/4" x 1 3/4" Cap Screws (#10), (2) 3/4" Flat Washers (#15), and (2) 3/4" Nylock Nuts (#16). Clamp in place so that the bottom edge of the Front Crossmember is parallel to the ground. Remaining holes will be dealt with in later steps.
4. Attach Mounting Assembly (#1) to the side plate of the Front Crossmember (#2) in the front set of vertical holes and secure using (6) 1/2" x 2" Cap Screws (#13) and (2) Nylock Nuts (#12).

MOUNTING INSTRUCTIONS

1. Remove vehicle front bumper. Retain, with hardware for replacement at end of installation.



WARNING

Beware of brake and fuel lines secured to inside wall of frame rails when drilling holes in vehicle frame!

FAILURE TO HEED CAN RESULT IN INJURY OR DEATH!

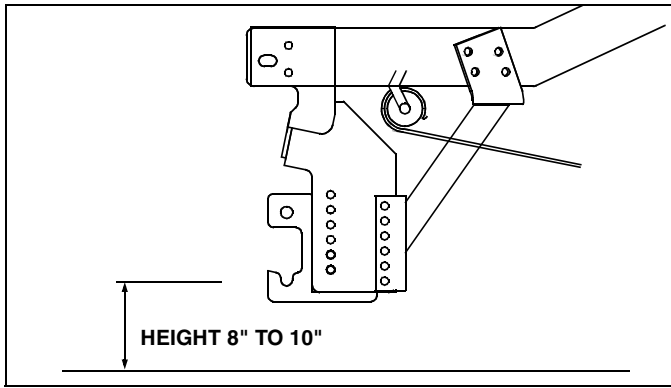

IMPORTANT: Height from the center of the lower plow mounting holes on the sub-frame to the ground should be between 9" and 12" to insure proper operation.

- Align holes in (1) Rear Mounting Bracket Assembly (#3) RH and (#4) LH with the back set of vertical holes on the Front Crossmember. Secure using (4) 1/2" x 2 1/4" (#14) and (4) Nylock Nuts (#12).

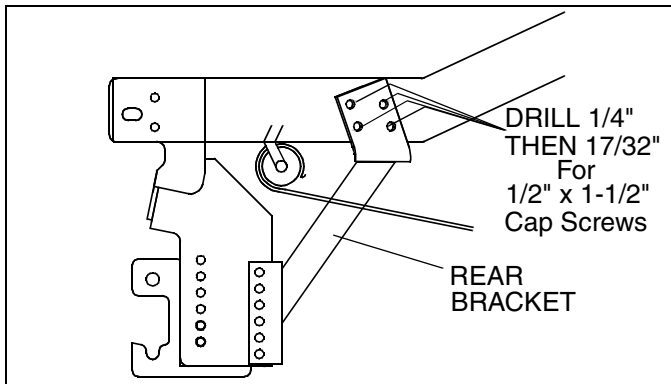

- Clamp upper leg of the Rear Bracket Assemblies to the vehicle frame. Adjust the position to avoid interference with steering components, and away from the radiator (on diesel models), making sure that the bottom of the "L" shaped bracket is butted up to the bottom of the frame. This may eliminate the ability to use the existing slot on some models. Using holes in the Rear Bracket Assemblies as a template, center punch, and drill 1/4", then 17/32" holes through the outer wall of the vehicle frame.
- Using (8) 1/2" x 1 1/2" Cap Screws (#8), (8) 1/2" Lock Washers (#9) and (4) Nut Plate Assemblies (#5 RH & #6 LH), secure Rear Brackets to the vehicle frame with wire handles facing the front of the vehicle.
- Using the remaining holes in the Front Crossmember as a template, center punch and drill 1/4" and then 17/32" holes through the vehicle frame rail. Secure Front Crossmember using (4) 1/2" x 1 1/2" Cap Screws (#8) and on the engine side (4) 1/2" Flat Washers (#11) and (4) 1/2" Nylock Nuts (#12).

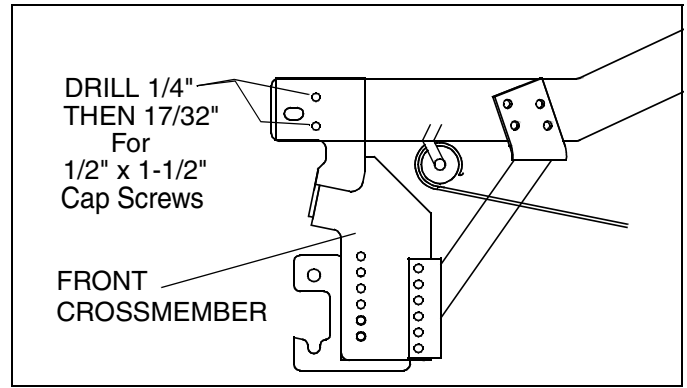

- Using the Torque Specification Chart below, torque all bolts starting at the rear and working forward.

TORQUE SPECIFICATIONS FOR STANDARD MACHINE HARDWARE					
Bolt Size	GR.2 Dry	GR.5 Dry	GR.8 Dry	Metric Size	GR.8.8 Dry
1/4"	66*	9	12	M8	17
5/16"	11	17	25	M10	35
3/8"	20	30	45	M12	60
7/16"	32	50	70	M14	95
1/2"	50	75	110	M16	155
9/16"	70	110	150		
5/8"	100	150	220		
3/4"	175	260	380		
7/8"	170	430	600		
1"	250	640	900		

Note: These torque values are to be used for all hardware. Unless otherwise specified, all torque values must meet this specification.
 Note: All torque values are in Ft.-Lbs unless otherwise stated
 Note: *In-Lbs

REMEMBER After 5 to 10 hours of snowplow usage, re-torque all Cap Screws!

- Replace the vehicle front bumper.

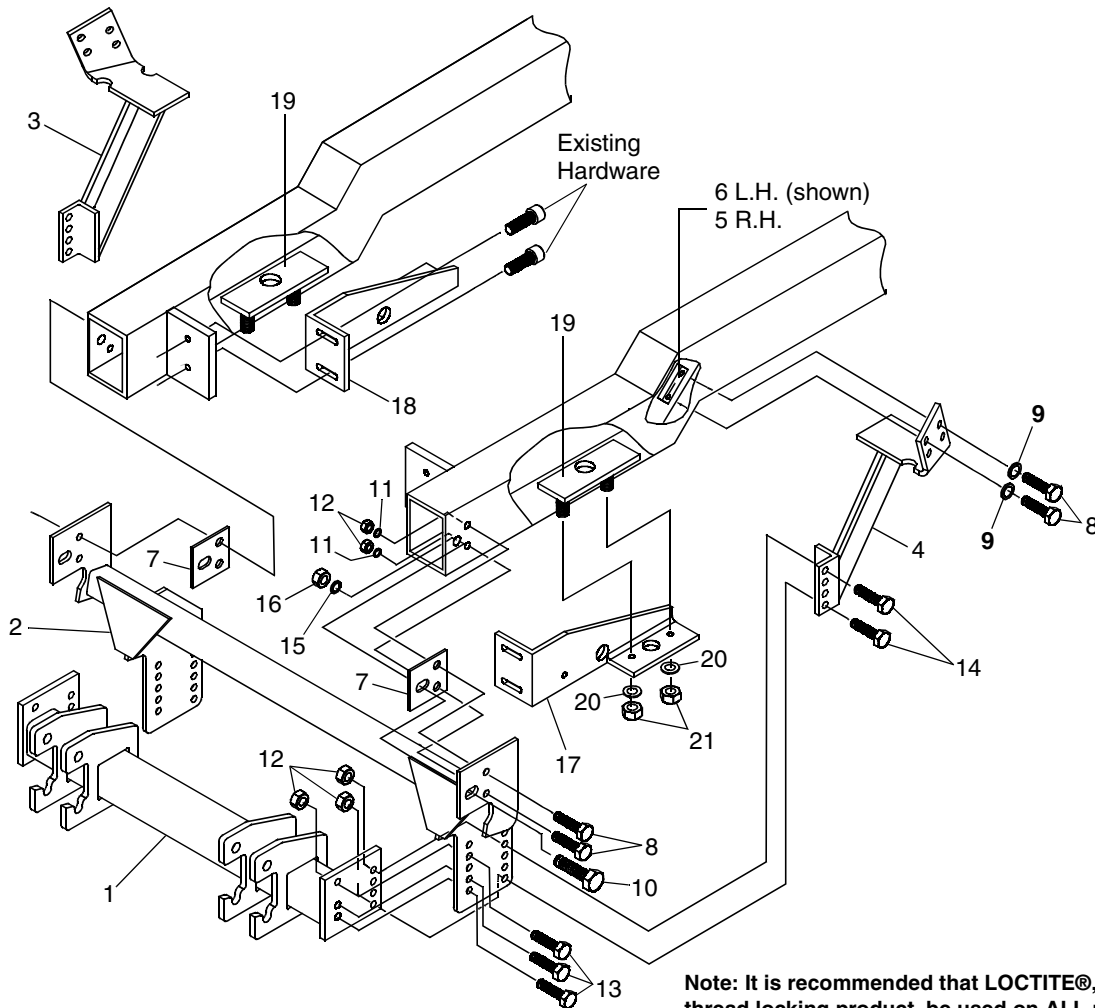

Note: It is recommended that LOCTITE®, or similar thread locking product, be used on ALL mounting hardware (i.e. Nuts, Cap Screws, Bolts, etc.).

ITEM	PART NO.	DESCRIPTION	QTY.
1	96106597	Mounting Assembly	1
2	96104063	Crossmember, Front.....	1
3	96103907	Assembly, Rear Mounting Bracket, RH	1
4	96103908	Assembly, Rear Mounting Bracket, LH.....	1
5	96100938	Plate, Assembly, Nut, RH	2
6	96100939	Plate, Assembly, Nut, LH.....	2
7	96102912	Plate, Shim, 5/16".....	4
8	98009010	Cap Screw, Hex Head, 1/2"-13 NC x 1 1/2"	12
9	98009012	Washer, Lock, 1/2".....	8
10	98009098	Cap Screw, Hex Head, 3/4"-10 NC x 1 3/4"	2
11	98009011	Washer, Flat, 1/2".....	4
12	98009013	Nut, Hex, Nylock, 1/2"-13 NC	14
13	98100094	Cap Screw, Hex Head, 1/2"-13 NC x 2"	6
14	98100062	Cap Screw, Hex Head, 1/2"-13 NC x 2 1/4"	4
15	98009030	Washer, Flat, 3/4".....	2
16	98009003	Nut, Hex, Nylock, 3/4"-10 NC	2
17	96104375	Bracket, Left	1
18	96104376	Bracket, Right.....	1
19	96104466	Plate, Bolt, Assembly.....	2
20	98009032	Washer, Flat 3/8".....	4
21	98009009	Nut, Hex, Nylock, 3/8"-16	4

SNO-WAY® INTERNATIONAL, INC.



Hartford, WI 53027 USA
 Website: www.snoway.com
 ©2005 Sno-Way® International