

SNO-WAY[®]

SNOW & ICE CONTROL EQUIPMENT

Assembly & Installation Instructions

**FOR
SUBFRAME COMPONENTS PACKAGE 99100681**

**TO FIT
2002 - LATER DODGE RAM 1500 4x4**



1. **THINK SAFETY, ALWAYS WEAR SAFETY GLASSES WHEN PERFORMING THE OPERATIONS PRESCRIBED IN THESE INSTRUCTIONS**
2. **READ ALL INSTRUCTIONS CAREFULLY BEFORE ATTEMPTING INSTALLATION**
3. **BEFORE BEGINNING WORK MAKE SURE TO SET PARKING BRAKE AND CHOCK WHEELS**



MINIMUM VEHICLE RECOMMENDATIONS

Heavy Duty Alternator
Heavy Duty Battery

NOTE: On some vehicles it may be necessary to use a form of load booster to decrease the vehicle's front suspension sag with the snow plow in place. This can be accomplished with the use of supplementary air bags, booster springs, or similar load boosting devices. Since there are different load boosting devices available, it will up to the customer/end user to decide and purchase the product to suit the application, and not the responsibility of Sno-Way International, Inc.

ASSEMBLY TOOLS NEEDED

Drill Bits	1/4", 17/32"
Impact Sockets	7/16" – 1-3/8"
Impact Sockets, Metric	10mm - 18mm
Wrenches	7/16" – 1-3/8"
Wrenches, Metric	10mm - 18mm
Torque Wrench	
Rat Tail Pry Bar	
Center Punch and Hammer	

INSTALLATION NOTES

1. **Unless otherwise specified, mount all Subframe Components to vehicle before tightening any hardware.**
2. **It is recommended that LOCTITE®, or similar thread locking product, be used on ALL mounting hardware (i.e. Nuts, Cap Screws, Bolts, etc.).**
3. Vehicle should be parked on a level surface with a normal vehicle load on the FRONT suspension.
4. Items in parentheses () refer to quantity required for this step. Items in parentheses with a pound sign (#) indicate the part number as found in the parts list on the last page of this document.
Example: (10) Washer, Lock, 1/2" (#8).
5. It maybe necessary to relocate license plate holder. Check state and local laws for placement, if needed.

the bumper so that the bumper brackets are between frame rails and Side Plates and secure again with the original bumper hardware.

4. Install (1) Mounting Assembly (#1). Secure to Side Plates using (6) 1/2" x 1-1/2" Cap Screws (#6). In the threaded holes use (2) 1/2" Lock Washers (#8) and for the non-threaded holes, use (4) 1/2" Lock Nuts (#7).
5. Attach (1) Rear Crossmember Assembly (#3) by aligning the holes in the Rear Crossmember Assembly with the corresponding holes in the Mounting Assembly. Be sure to keep the back portion of the Rear Crossmember Assembly tight against the vehicle crossmember. If needed, clamp into place until holes are drilled. For the holes in the vertical piece of the crossmember, use the holes as a template, center punch and drill 1/4" then a 17/32" holes through the crossmember front wall. Secure using (2) 1/2" x 1-1/2" Cap Screws (#6) and (2) Lock Nuts (#7). For the holes in the horizontal piece of the crossmember, first slide in (1) Backing Plate (#5) through the open end of the vehicle crossmember. Align with the holes in the Rear Crossmember Assembly and secure using (2) 1/2" x 1-1/2" Cap Screws (#6) and (2) 1/2" Lock Nuts (#7).

MOUNTING INSTRUCTIONS

1. Remove splash shield from under vehicle. Retain with hardware for future use if subframe is removed.
2. Remove vehicle's front bumper. Retain hardware for reinstallation in step 3.
3. Install Side Plates (#2) at the inside of the truck frame, one on each side, with the notch facing the front and the two upper front holes aligned with bumper mounting holes. Temporarily secure with existing bumper hardware.
Using the upper rear Side Plate holes as a template, center punch and drill (2) 1/4", then 17/32" holes through the inside of the frame. Loosen hardware. Install (1) Nut Plate Assembly (#4) inside each frame rail, aligned with the drilled holes. Position a Spacer (#9) between each Side Plate and frame rail, align with the drilled holes and secure with (2) 1/2" x 1-1/2" Cap Screws (#6) and (2) 1/2" Lock Washers (#8). Remove the hardware from the front holes, re-install

6. Using the Torque Specification Chart provided, torque all bolts starting at the rear and working forward.

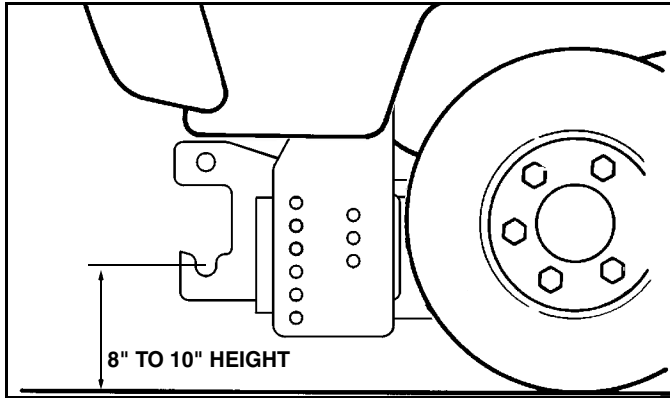

Figure 1

IMPORTANT: Height from the center of the lower Plow Mounting holes on the Subframe to the ground should be between 8" and 10" to insure proper operation.

TORQUE SPECIFICATIONS FOR STANDARD MACHINE HARDWARE					
Bolt Size	GR.2 Dry	GR.5 Dry	GR.8 Dry	Metric Size	GR.8.8 Dry
1/4"	66*	9	12	M8	17
5/16"	11	17	25	M10	35
3/8"	20	30	45	M12	60
7/16"	32	50	70	M14	95
1/2"	50	75	110	M16	155
9/16"	70	110	150		
5/8"	100	150	220		
3/4"	175	260	380		
7/8"	170	430	600		
1"	250	640	900		

Note: These torque values are to be used for all hardware. Unless otherwise specified, all torque values must meet this specification.
 Note: All torque values are in Ft.-Lbs unless otherwise stated
 Note: *In-Lbs

REMEMBER After 5 to 10 hours of snowplow usage, re-torque all Cap Screws!

PARTS LIST

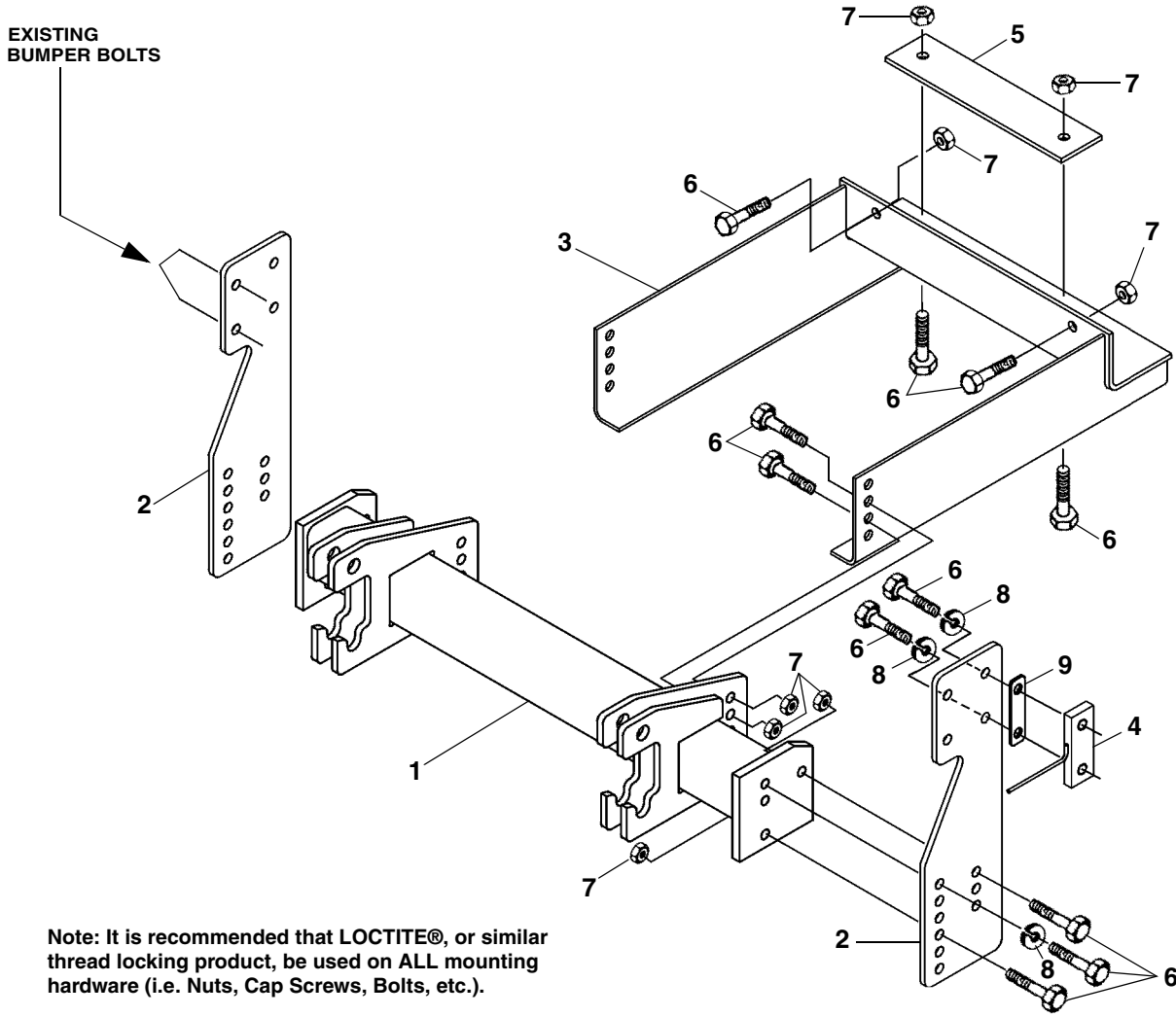

Note: It is recommended that LOCTITE®, or similar thread locking product, be used on ALL mounting hardware (i.e. Nuts, Cap Screws, Bolts, etc.).

ITEM	PART NO.	DESCRIPTION	QTY.
1	96107312	Mounting Assembly	1
2	96105438	Side Mounting Plate	2
3	96105473	Rear Crossmember Assembly	1
4	96105595	Nut Plate Assembly	2
5	96105651	Backing Plate	1
6	98009010	Cap Screw, Hex Head, 1/2"-13 x 1 1/2"	18
7	98009013	Nut, Hex Head, Nylock, 1/2"	12
8	98009012	Washer, Lock, 1/2"	6
9	96107987	Spacer.....	2

SNO-WAY® INTERNATIONAL, INC.



Hartford, WI 53027 USA
Website: www.snoway.com
©2005 Sno-Way® International