

SNO-WAY[®]

SNOW & ICE CONTROL EQUIPMENT

Assembly & Installation Instructions

**FOR
SUBFRAME COMPONENTS PACKAGE 99100686**

**TO FIT
2004 - LATER DODGE DURANGO
2005 - LATER DODGE DAKOTA**



1. **THINK SAFETY, ALWAYS WEAR SAFETY GLASSES WHEN PERFORMING THE OPERATIONS PRESCRIBED IN THESE INSTRUCTIONS**
2. **READ ALL INSTRUCTIONS CAREFULLY BEFORE ATTEMPTING INSTALLATION**
3. **BEFORE BEGINNING WORK MAKE SURE TO SET PARKING BRAKE AND CHOCK WHEELS**



MINIMUM VEHICLE RECOMMENDATIONS

Heavy Duty Alternator Heavy Duty Battery

NOTE: On some vehicles it may be necessary to use a form of load booster to decrease the vehicle's front suspension sag with the snow plow in place. This can be accomplished with the use of supplementary air bags, booster springs, or similar load boosting devices. Since there are different load boosting devices available, it will up to the customer/end user to decide and purchase the product to suit the application, and not the responsibility of Sno-Way International, Inc.

ASSEMBLY TOOLS NEEDED

Drill Bits	1/4", 17/32"
Impact Sockets	7/16" – 1-3/8"
Metric Sockets	10 mm – 19 mm
Wrenches	7/16" – 1-3/8"
Metric Wrenches	10 mm – 19 mm
Torque Wrench	
Rat Tail Pry Bar	
Clamping Devices	

INSTALLATION NOTES

1. **Unless otherwise specified, mount all Subframe Components to vehicle before tightening any hardware.**
2. **It is recommended that LOCTITE®, or similar thread locking product, be used on ALL mounting hardware (i.e. Nuts, Cap Screws, Bolts, etc.).**
3. Vehicle should be parked on a level surface with a normal vehicle load on the FRONT suspension.
4. Items in parentheses () refer to quantity required for this step. Items in parentheses with a pound sign (#) indicate the part number as found in the parts list on the last page of this document.
Example: (2) 5/8" x 1-1/2" Cap Screws (#7).
5. It may be necessary to relocate license plate holder. Check state and local laws for placement, if needed.

Bracket Assy, LH (#3) using (1) Shim Plate (#4) (on upper position), (1) Rear Attach Bracket (#6), (4) 1/2"-13 x 1-1/2" Cap Screws (#7) and (4) 1/2"-13 Nylock Nuts (#9). Using the front 2 holes on the Front Mounting Bracket Assy, LH (#3) as a template, drill 1/4" pilot holes then drill to 17/32". Secure using (1) Nut Plate (#5) (inserted through the front of the frame rail) (2) 1/2"-13 x 1-1/2" Cap Screws (#7) and (2) 1/2" Lock Washers (#8).

4. Install Mounting Assembly (#1) by securing it between items #2 and #3. Secure each side using (4) 1/2"-13 x 1-1/2" Cap Screws (#7), (1) 1/2" Lock Washer (#8) in the threaded holes, and (3) 1/2" Nylock Nuts (#9).

IMPORTANT: Height from the center of the lower Plow mounting holes on the Subframe to the ground should be between 8" and 10" to insure proper operation.

MOUNTING INSTRUCTIONS

1. Remove the bumper by removing the (8) fasteners connecting the front bumper to the vehicle frame. Retain the hardware to re-install the bumper in a later step.
2. Position Side Attach Plate, RH (#2) to the inside of the vehicle frame rail on the passenger side just behind the raised oval on the inside of the vehicle frame rail. Item #2 is tapered to fit the frame rail. Loosely secure the rear portion of the Side Attach Plate, RH (#2) using (1) Shim Plate (#4) (on upper position), (1) Rear Attach Bracket (#6), (4) 1/2"-13 x 1-1/2" Cap Screws (#7) and (4) 1/2"-13 Nylock Nuts (#9). Item #6 is also tapered to fit the frame rail, and will only fit properly in the correct orientation. Using the front 2 holes on the Side Attach Plate, RH (#2) as a template, drill 1/4" pilot holes, then drill to 17/32". Secure using (1) Nut Plate (#5) (inserted through the front of the frame rail) (2) 1/2"-13 x 1-1/2" Cap Screws (#7) and (2) 1/2" Lock Washers (#8).
3. Position Front Mounting Bracket Assy, LH (#3) to the inside of the vehicle frame rail on the passenger side just behind the raised oval on the inside of the vehicle frame rail. Item #3 is tapered to fit the frame rail. Loosely secure the rear portion of the Front Mounting

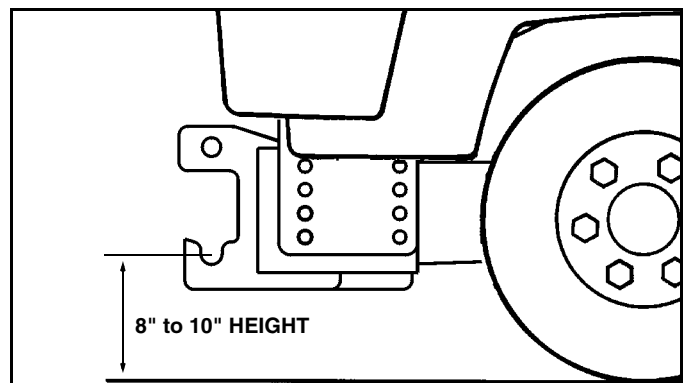

5. Using the torque specification chart provided, torque all cap screws.

**TORQUE SPECIFICATIONS FOR
STANDARD MACHINE HARDWARE**

Bolt Size	GR.2 Dry	GR.5 Dry	GR.8 Dry	Metric Size	GR.8.8 Dry
1/4"	66*	9	12	M8	17
5/16"	11	17	25	M10	35
3/8"	20	30	45	M12	60
7/16"	32	50	70	M14	95
1/2"	50	75	110	M16	155
9/16"	70	110	150		
5/8"	100	150	220		
3/4"	175	260	380		
7/8"	170	430	600		
1"	250	640	900		

Note: These torque values are to be used for all hardware. Unless otherwise specified, all torque values must meet this specification.

Note: All torque values are in Ft.-Lbs unless otherwise stated

Note: *In-Lbs

REMEMBER *After 5 to 10 hours of snowplow usage, re-torque all Cap Screws!*

6. Reinstall bumper using original hardware.

NOTE: Modification of the bumper is necessary to obtain height needed for the snow plow.

PARTS LIST

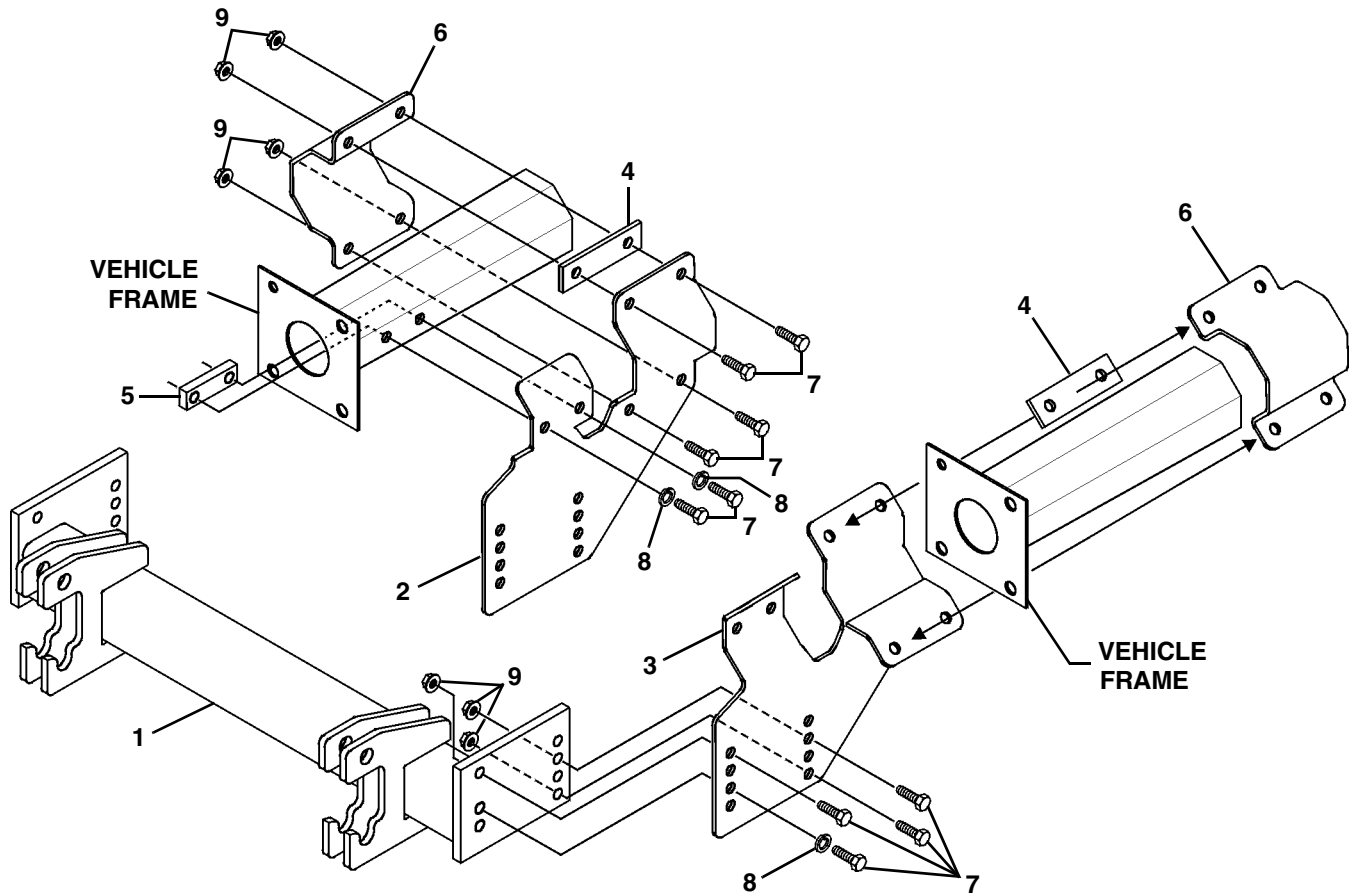

Note: It is recommended that LOCTITE®, or similar thread locking product, be used on ALL mounting hardware (i.e. Nuts, Cap Screws, Bolts, etc.).

ITEM	PART NO.	DESCRIPTION	QTY.
1	96107317	Assembly, Mounting	1
2	96107327	Plate, Side Attach, RH.....	1
3	96107319	Assembly, Front Mounting Bracket, LH.....	1
4	96107361	Plate, Shim	2
5	96100940	Plate, Nut.....	2
6	96107360	Bracket, Rear Attach	2
7	98009010	Cap Screw, Hex Head, 1/2"-13 x 1-1/2"	20
8	98009012	Washer, Lock, 1/2" Heavy	6
9	98009013	Nut, Hex, Nylock, 1/2"-13	14

SNO-WAY® INTERNATIONAL, INC.

SNO-WAY
SNOW & ICE CONTROL EQUIPMENT

Hartford, WI 53027 USA
Website: www.snoway.com
©2005 Sno-Way® International