



**Assembly
&
Installation Instructions**

**FOR
SUBFRAME COMPONENTS PACKAGE 99100687
AND
SUBFRAME NOSE PIECE PACKAGE 96107339**

**TO FIT
97 LATER FORD F150
97 LATER FORD F250 (LD)
97 LATER FORD EXPEDITION**



1. **THINK SAFETY, ALWAYS WEAR SAFETY GLASSES WHEN PERFORMING THE OPERATIONS PRESCRIBED IN THESE INSTRUCTIONS**
2. **READ ALL INSTRUCTIONS CAREFULLY BEFORE ATTEMPTING INSTALLATION**
3. **BEFORE BEGINNING WORK MAKE SURE TO SET PARKING BRAKE AND CHOCK WHEELS**



MINIMUM VEHICLE RECOMMENDATIONS

Heavy Duty Alternator
 Heavy Duty Battery
 Manufacturer's Snow Plow Package

NOTE: On some vehicles it may be necessary to use a form of load booster to decrease the vehicle's front suspension sag with the snow plow in place. This can be accomplished with the use of supplementary air bags, booster springs, or similar load boosting devices. Since there are different load boosting devices available, it will up to the customer/end user to decide and purchase the product to suit the application, and not the responsibility of Sno-Way International, Inc.

ASSEMBLY TOOLS NEEDED

Drill Bits 1/4", 17/32"
 Impact Sockets 7/16" – 1-3/8"
 Wrenches 7/16" – 1-3/8"
 Torque Wrench
 Rat Tail Pry Bar
 Center Punch and Hammer
 Clamping Devices ("C", Bar, type device)
 Hacksaw

INSTALLATION NOTES

1. **Unless otherwise specified, mount all Sub-Frame Components to vehicle before tightening any hardware.**
2. **It is recommended that LOCTITE®, or similar thread locking product, be used on ALL mounting hardware (i.e. Nuts, Cap Screws, Bolts, etc.).**
3. Vehicle should be parked on a level surface with a normal vehicle load on the FRONT suspension.
4. Items in parentheses () refer to quantity required for this step. Items in parentheses with a pound sign (#) indicate the part number as found in the parts list on the last page of this document.
 Example: (10) Washer, Lock, 1/2" (#8).
5. It maybe necessary to relocate license plate holder. Check state and local laws for placement, if needed.

MOUNTING INSTRUCTIONS

F-250 (LD) only:

1. Remove splashguard and remaining hardware from the underside of the vehicle. Retain hardware for future reinstallation if the sub-frame is removed.
2. Relocate the license plate if required. (See installation note #5.)
3. Remove tow hooks and hardware. Retain for reinstallation if sub-frame is removed.

F-150 and F-250 (LD):

1. Remove the vehicle front bumper assembly. Retain hardware for reinstallation.
2. Remove air dam from bumper with hardware and retain for future use if sub-frame is removed.
3. Remove tow hooks and hardware.
4. Place (2) Nut Plates (#12) inside the vehicle frame and align holes with the tow hook mounting holes. Align

- (1) Mounting Bracket, LH (#2) and (1) Mounting Bracket, RH (#3) with the tow hook mounting holes and the nut plate holes. Secure using (4) 1/2" x 2" Cap Screws (#6), (4) 1/2" Lock Washers (#10), and (4) 1/2" Flat Washers (#9). (2 of each on each side) Then, using the hole in the Mounting Brackets, LH and RH as a template, center punch and drill 1/4" pilot holes through the outside of the vehicle frame rail. Remove brackets, drill to 17/32", using the pilot holes for alignment. Secure using (2) 1/2" x 1 1/2" Cap Screw (#8), (2) 1/2" Lock Washers (#10) and inserted through the front of the frame (2) Nut Plates (#13). Secure the bottom of the brackets with the same hardware used to hold the in place for drilling.
5. Next, install (1) Mounting Assembly (#1). Align the holes on the side Mounting Brackets just installed with the holes in the side plates of the Mounting Assembly. In the front two holes, secure the Mounting Assembly with (4) 1/2" x 1 1/2" Cap Screws (#8) – the top hole secure with (2) 1/2" Nylock Nuts (#7) – the threaded hole use (2) 1/2" Lock Washers (#10).
6. Now install the Rear Mounting Brackets LH (#4) and RH (#5). Align the bottom holes in the Rear Mounting Brackets with the back holes of the Mounting Assembly and the side Mounting Brackets. Insert (4) 1/2" x 2" Cap Screw (#6) and hold in place with (4) 1/2" Nylock Nuts (#7).
7. Align Rear Mounting Brackets lowest hole with the existing slot in the vehicle frame insuring the Mounting Brackets are tight with the bottom of the vehicle frame; clamp into place. Using the (4) holes in the Rear Mounting Brackets (#4) LH and (#5) RH as a template, center punch and drill (4) 1/4" pilot holes through the outside of the frame rail. Remove both Mounting Brackets from the vehicle and Mounting Assembly. Drill out the 1/4 holes with a 17/32" drill through the outside of the frame walls of the vehicle frame rail using the 1/4" pilot holes for alignment.

8. Secure the Rear Mounting Brackets and the Mounting Assembly as follows:
 - Reattach Rear Mounting Brackets with the same hardware used in step #6.
 - Insert the Nut Plate Assembly (#11) through the opening in the vehicle frame and align with drilled holes. Secure with (3) 1/2" x 1-1/2" Cap Screws (#8) and (3) 1/2" Lock Washers (#10). Repeat this procedure on the other side.
9. Using the Torque Specification Chart provided, torque all cap screws.
10. Reinstall the bumper.

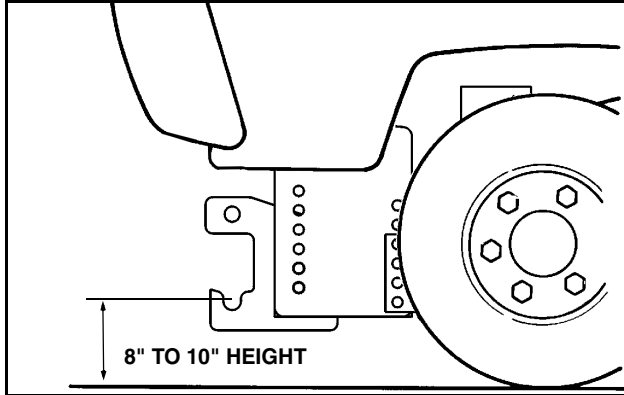

IMPORTANT: Height from the center of the lower Plow Mounting holes on the Sub-Frame to the ground should be between 8" and 10" to insure proper operation.

TORQUE SPECIFICATIONS FOR STANDARD MACHINE HARDWARE					
Bolt Size	GR.2 Dry	GR.5 Dry	GR.8 Dry	Metric Size	GR.8.8 Dry
1/4"	66*	9	12	M8	17
5/16"	11	17	25	M10	35
3/8"	20	30	45	M12	60
7/16"	32	50	70	M14	95
1/2"	50	75	110	M16	155
9/16"	70	110	150		
5/8"	100	150	220		
3/4"	175	260	380		
7/8"	170	430	600		
1"	250	640	900		

Note: These torque values are to be used for all hardware. Unless otherwise specified, all torque values must meet this specification.
 Note: All torque values are in Ft.-Lbs unless otherwise stated
 Note: *In-Lbs

REMEMBER After 5 to 10 hours of snowplow usage, re-torque all Cap Screws!

PARTS LIST

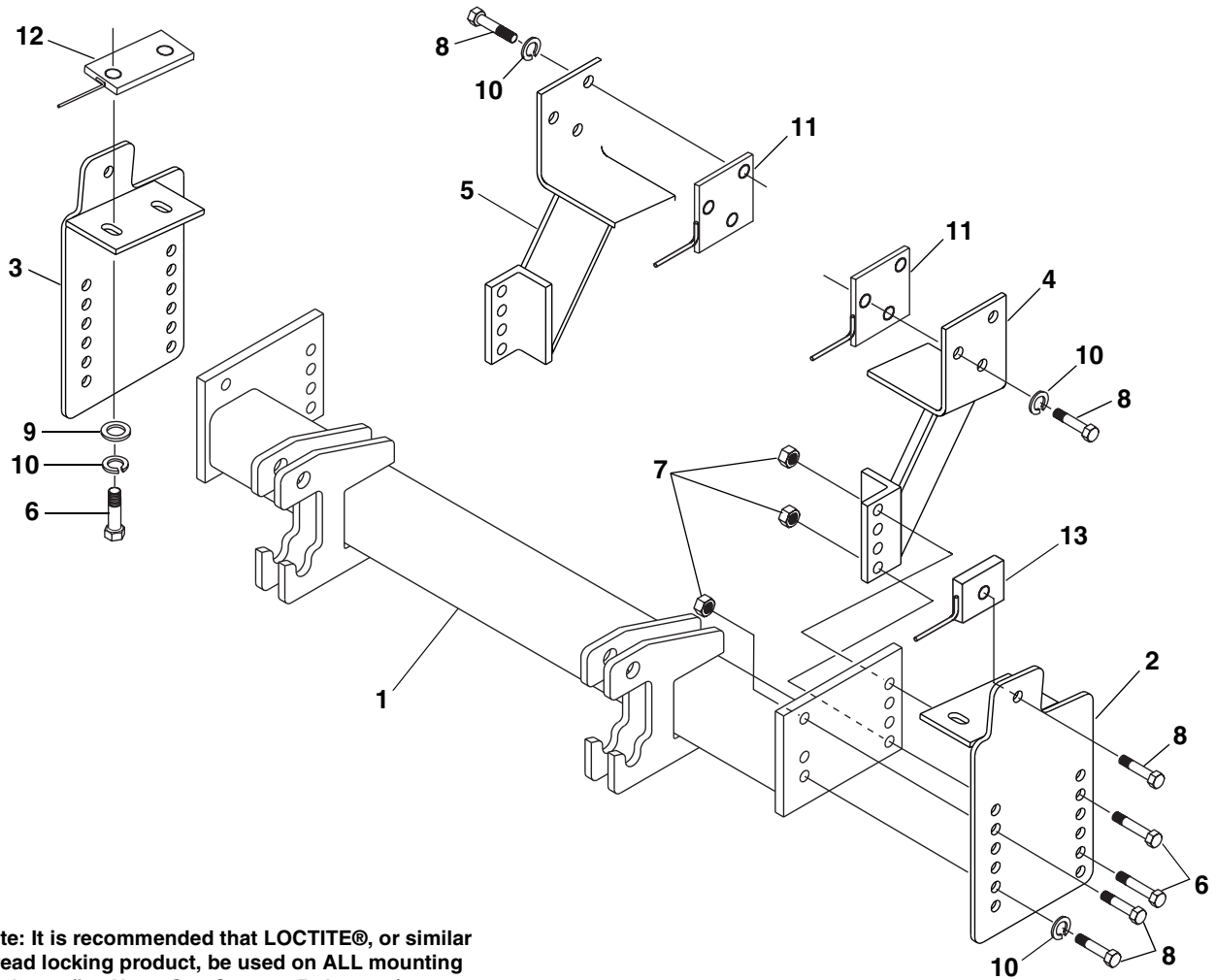

Note: It is recommended that LOCTITE®, or similar thread locking product, be used on ALL mounting hardware (i.e. Nuts, Cap Screws, Bolts, etc.).

ITEM	PART NO.	DESCRIPTION	QTY.
1	96107339	Assembly, Mounting	1
2	96105802	Bracket, Mounting, LH	1
3	96105803	Bracket, Mounting, RH	1
4	96105823	Bracket, Rear Mounting, LH	1
5	96105824	Bracket, Rear Mounting, RH	1
6	98100094	Cap Screw, Hex Head, 1/2"-13 NC x 2"	8
7	98009013	Nut, Hex, Nylock, 1/2"-13 NC	6
8	98009010	Cap Screw, Hex Head, 1/2"-13 NC x 1-1/2"	12
9	98009011	Washer, Flat, 1/2"	4
10	98009012	Washer, Lock, 1/2"	14
11	96104386	Assembly, Nut Plate	2
12	96102726	Plate, Nut	2
13	96103505	Plate, Nut	2

SNO-WAY® INTERNATIONAL, INC.

Hartford, WI 53027 USA
 Website: www.snoway.com
 ©2004 Sno-Way® International