

SNO-WAY[®]

SNOW & ICE CONTROL EQUIPMENT

Assembly & Installation Instructions

**FOR
SUBFRAME COMPONENTS PACKAGE 99100727**

**TO FIT
2005 - LATER FORD F450 & F550 SUPER DUTY SERIES 4x4**



1. THINK SAFETY, ALWAYS WEAR SAFETY GLASSES WHEN PERFORMING THE OPERATIONS PRESCRIBED IN THESE INSTRUCTIONS
2. READ ALL INSTRUCTIONS CAREFULLY BEFORE ATTEMPTING INSTALLATION
3. BEFORE BEGINNING WORK MAKE SURE TO SET PARKING BRAKE AND CHOCK WHEELS



MINIMUM VEHICLE RECOMMENDATIONS

Heavy Duty Alternator Heavy Duty Battery
Manufacturers Snow Plow Package

NOTE: On some vehicles it may be necessary to use a form of load booster to decrease the vehicle's front suspension sag with the snow plow in place. This can be accomplished with the use of supplementary air bags, booster springs, or similar load boosting devices. Since there are different load boosting devices available, it will up to the customer/end user to decide and purchase the product to suit the application, and not the responsibility of Sno-Way International, Inc.

ASSEMBLY TOOLS NEEDED

Drill Bits	1/4", 17/32"
Impact Sockets	7/16" – 1-3/8"
Impact Sockets Metric	10mm – 19mm
Wrenches	7/16" – 1-3/8"
Wrenches Metric	10mm – 19mm
Torque Wrench	Rat Tail Pry Bar
Center Punch and Hammer	
Clamping Device ("C", Bar, type device...)	

INSTALLATION NOTES

1. Unless otherwise specified, mount all Subframe Components to vehicle before tightening any hardware.
2. It is recommended that LOCTITE®, or similar thread locking product, be used on ALL mounting hardware (i.e. Nuts, Cap Screws, Bolts, etc.).
3. Vehicle should be parked on a level surface with a normal vehicle load on the FRONT suspension.
4. Items in parentheses () refer to quantity required for this step. Items in parentheses with a pound sign (#) indicate the part number as found in the parts list on the last page of this document.
Example: (2) 1/2" x 13 x 1-1/2" Cap Screws (#9).
5. It maybe necessary to relocate license plate holder. Check state and local laws for placement, if needed.

remove the BlockerBeam™ and tow hooks from the truck frame. Retain, with hardware, for future use if sub-frame is removed. **BlockerBeam™ must be reinstalled if the sub-frame is ever removed, and must be transferred when vehicle is sold or traded.**

2. Remove the bumper by first removing any electrical cords attached to bumper (diesel engine and vehicles with fog lamps). Remove the bumper fasteners and save with BlockerBeam™.

MOUNTING INSTRUCTIONS



WARNING

According to the Ford Owner Guide, removing the BlockerBeam™ without installing snow plow attachment hardware may affect air bag deployment in a crash. DO NOT operate the truck unless either the BlockerBeam™ or snow plow attachment hardware is installed on the vehicle! FAILURE TO HEED CAN RESULT IN INJURY OR DEATH!

1. This vehicle is equipped with a new detachable BlockerBeam™. It is attached to the frame horns, behind the bumper. Disconnect the rubber air deflector from the BlockerBeam™, then unbolt and

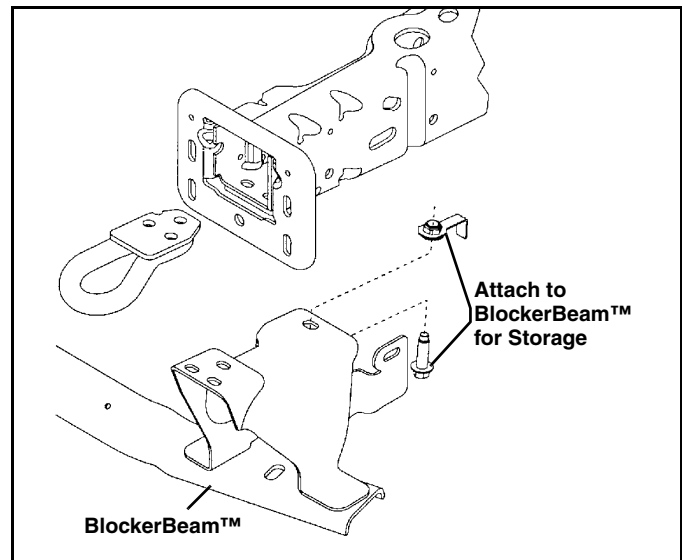

NOTE: It may be necessary to install spacers (provided) between the bumper mounting plate and the Front Plates (#2 and #3) to ensure proper hole alignment between the Front Plates and Rear Brackets when hardware is secured.

*Test fit by loosely attaching a Front Plate, Front Bracket and Rear Bracket on one side of the vehicle (refer to Step 4, then Steps 6-8). **Do not install carriage bolts securing the Front Plate to the bumper mounting plate at this time.***

Align the mounting holes in the Front Plate and Rear Bracket, then check for a gap between the Front Plate

and bumper mounting plate. If a gap exists, add Spacers (#19 and/or #20) to fill the gap and maintain mounting hole alignment when all hardware is installed and tightened. Included in the hardware bag are (4) 1/2" x 2-1/2" Carriage Bolts to secure the Front Plates (#2 and #3) to the bumper mounting plate if Spacers are used.

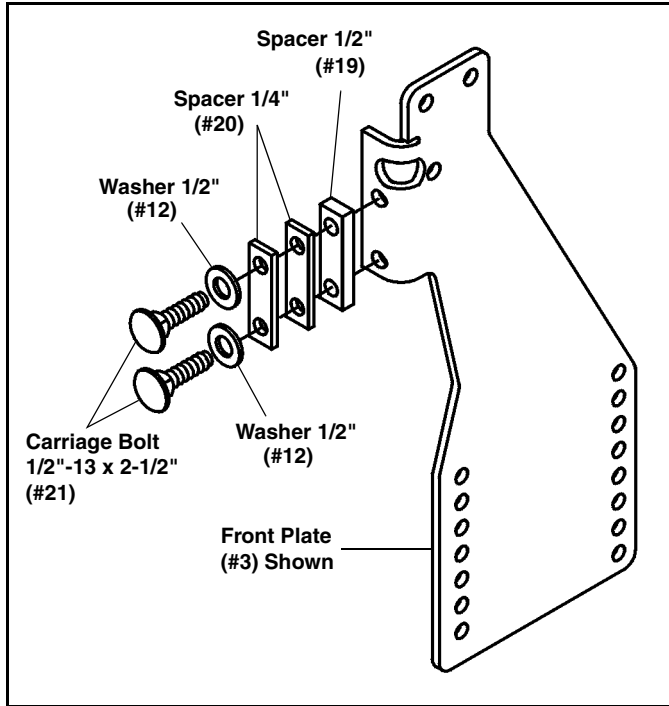

3. Install the Front Plates (#2, RH and #3, LH) at the inside of the frame, aligning with existing holes in the bumper mounting plate. Insert (4) 1/2" Carriage Bolts (#11, no spacers) or (#21, with spacers) in the slots on the inward side of the tow hooks and secure the Front Plates with (4) 1/2" Lock Washers (#15) and (4) 1/2" Hex Bolts (#16).
4. Position the Front Brackets, (#6, LH and #7, RH) over the top of the truck frame and secure to the Front Plates (#2 and #3) with (4) 1/2" x 1-1/2" Cap Screws (#10) and (4) 1/2" Nylock Nuts (#13). Tighten the Nylock Nuts for proper alignment in the following steps.

WARNING

Beware of brake and fuel lines secured to inside wall of frame rails when drilling holes in vehicle frame!

FAILURE TO HEED CAN RESULT IN INJURY OR DEATH!

5. Using the Front Plates and Brackets as a template, drill 1/4", then 17/32" holes through the sides of the truck frame in six places. Secure using (6) 1/2" x 1-3/4"

Cap Screws (#14) and (6) 1/2" Nylock Nuts (#13).

6. Install the Rear Brackets, (#4, LH and #5, RH). First, remove the four sway bar bracket bolts and remove the retained nut plates from the sway bar bracket. Allow the sway bar bushings and U-bracket to separate from the vehicle frame.
7. Remove the U-brackets for the sway bar. Drill the two holes in each U-bracket to 17/32" to allow clearance for 1/2" bolts. Save for installation in next step.

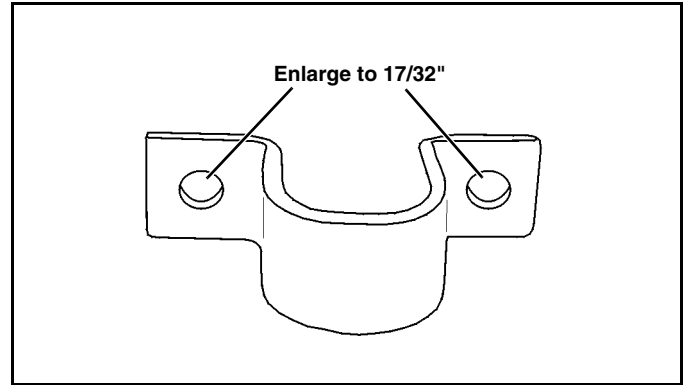

8. Insert the Rear Brackets (#4, LH and #5, RH) between the bottom of the sway bar bracket and the U-brackets, just drilled. To take up the gap between the sway bar block and the frame, insert (2) Spacers (#18). Loosely attach the Rear Brackets using (4) 1/2" x 1-3/4" Cap Screws (#14), (8) 1/2" Flat Washers (#12) (2 on top of the sway bar bracket and 2 on the bottom of the modified U-bracket per side) and (4) 1/2" Nylock Nuts (#13). Align the third hole on the same plate of the Rear Brackets with the existing hole in the bottom of the frame (remove the existing nut plate from the inside of the frame rail). Secure each side using (1) 1/2" x 1-1/2" Cap Screw (#10), (1) 1/2" Lock Washer (#15) and (1) Nut Plate (#9), inserted through the front of the frame rail.

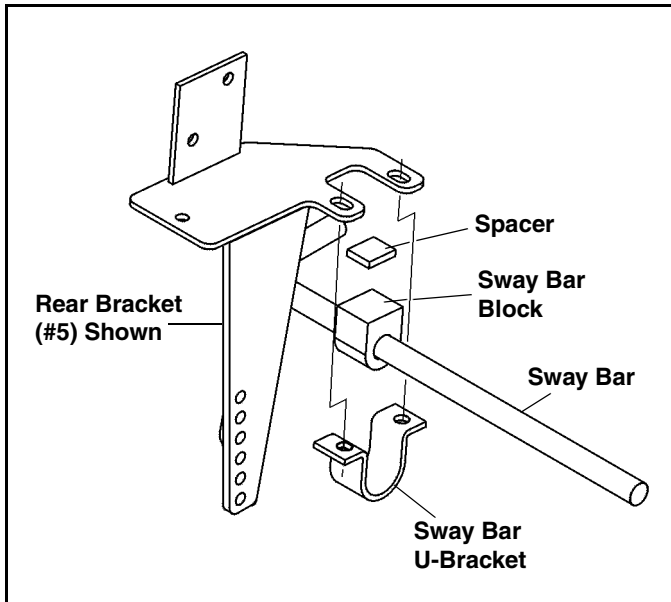

9. Align the front side hole of each Rear Bracket with an existing vehicle frame hole. Using the remaining hole as a template, drill a 1/4", then 17/32" hole in the frame. Insert (2) Nut plates (#9) through the front of each frame rail. Align a Bumper Bracket (#8) with the front lower hole at each side. Secure that hole in each Bumper Bracket using (1) 1/2" x 1-3/4" Cap Screw (#14) and (1) 1/2" Lock Washer (#15). Secure each drilled hole with (1) 1/2" x 1-1/2" Cap Screw (#10) and (1) 1/2" Lock Washer (#15).

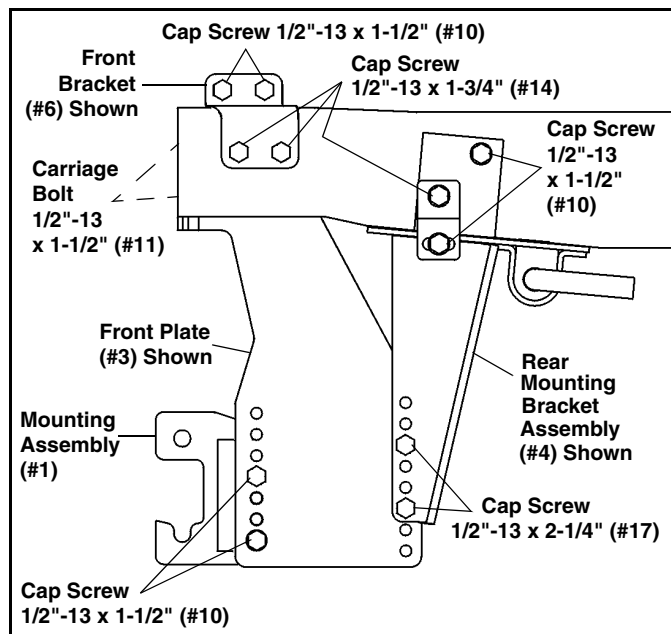

10. Attach the Mounting Assembly (#1) to the Front Plates (#2 and #3) in the front set of vertical holes and secure using (4) 1/2" x 1-1/2" Cap Screws (#10), (2) 1/2" Lock Washers (#15) in the threaded holes, and (2) 1/2" Nylock Nuts (#13). Align the rear set of

vertical holes in the Mounting Assembly (#1) with the rear set of vertical holes in the Side Plates (#2 and #3) and with the vertical holes in the Rear Brackets (#4 and #5). Secure using (4) 1/2" x 2-1/4" Cap Screws (#17) and (4) 1/2" Nylock Nuts (#13).

11. Using the Torque Specification Chart below, torque all bolts, **starting at the rear** and working forward.

TORQUE SPECIFICATIONS FOR STANDARD MACHINE HARDWARE					
Bolt Size	GR.2 Dry	GR.5 Dry	GR.8 Dry	Metric Size	GR.8.8 Dry
1/4"	66*	9	12	M8	17
5/16"	11	17	25	M10	35
3/8"	20	30	45	M12	60
7/16"	32	50	70	M14	95
1/2"	50	75	110	M16	155
9/16"	70	110	150		
5/8"	100	150	220		
3/4"	175	260	380		
7/8"	170	430	600		
1"	250	640	900		

Note: These torque values are to be used for all hardware. Unless otherwise specified, all torque values must meet this specification.
 Note: All torque values are in Ft.-Lbs unless otherwise stated
 Note: *In-Lbs

12. Reinstall the bumper using the existing hardware at the frame horns and using (2) 1/2" x 1-1/2" Cap Screws (#10), (4) 1/2" Flat washers (#12) and (2) 1/2" Nylock Nuts (#13). Reattach any electrical cords removed during bumper removal.

REMEMBER After 5 to 10 hours of snowplow usage, re-torque all Cap Screws!

PARTS LIST

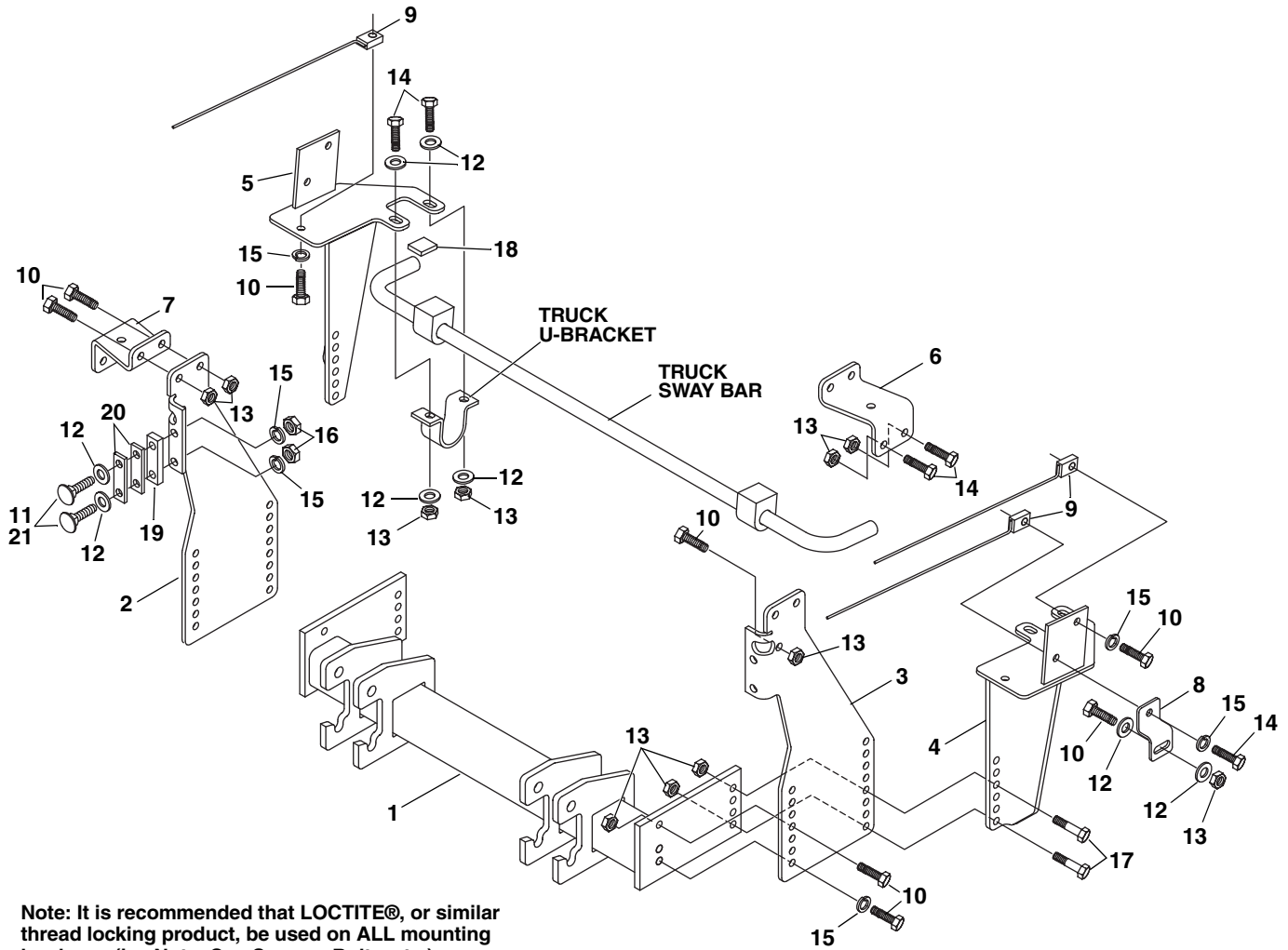

Note: It is recommended that LOCTITE®, or similar thread locking product, be used on ALL mounting hardware (i.e. Nuts, Cap Screws, Bolts, etc.).

ITEM	PART NO.	DESCRIPTION	QTY.
1	96106097	Mounting Assembly	1
2	96103547	Front Plate, R.H.	1
3	96103548	Front Plate, L.H.	1
4	96107572	Rear Bracket, L.H.	1
5	96107573	Rear Bracket, R.H.	1
6	96103546	Front Bracket, L.H.	1
7	96103545	Front Bracket, R.H.	1
8	96107599	Bumper Bracket.....	2
9	96103509	Nut Plate Assembly	6
10	98009010	Cap Screw, Hex Head, 1/2"-13 x 1-1/2"	16
11	98009171	Carriage Bolt, 1/2"-13 x 1-1/2".....	4
12	98009011	Washer, Flat, 1/2"	16
13	98009013	Nut, Hex Nylock, 1/2"-13	22
14	98100095	Cap Screw, Hex Head, 1/2"-13 x 1-3/4"	10
15	98009012	Washer, Lock, 1/2"	12
16	98009076	Nut, Hex, 1/2"-13	4
17	98100062	Cap Screw, Hex Head, 1/2"-13 x 2-1/4"	4
18	96107713	Spacer	2
19	96107981	Spacer, 1/2"	2
20	96107982	Spacer, 1/4"	4
21	98100330	Carriage Bolt, 1/2"-13 x 2-1/2".....	4

SNO-WAY[®] INTERNATIONAL, INC.

SNO-WAY[®]
SNOW & ICE CONTROL EQUIPMENT

Hartford, WI 53027 USA
Website: www.snoway.com
©2005 Sno-Way[®] International