

SNO-WAY[®]

SNOW & ICE CONTROL EQUIPMENT

Assembly & Installation Instructions

**FOR
SUBFRAME COMPONENTS PACKAGE 99100750**

**TO FIT
1994 - 2001 DODGE RAM, BR1500 4x4**



1. **THINK SAFETY, ALWAYS WEAR SAFETY GLASSES WHEN PERFORMING THE OPERATIONS PRESCRIBED IN THESE INSTRUCTIONS**
2. **READ ALL INSTRUCTIONS CAREFULLY BEFORE ATTEMPTING INSTALLATION**
3. **BEFORE BEGINNING WORK MAKE SURE TO SET PARKING BRAKE AND CHOCK WHEELS**



MINIMUM VEHICLE RECOMMENDATIONS

Heavy Duty Alternator(4x2, 4x4)
 Heavy Duty Battery (4x2, 4x4)
 Air-Adjustable Suspension Kit (4x2, 4x4)
 Manufacturers Snowplow Package (4x2, 4x4)

NOTE: On some vehicles it may be necessary to use a form of load booster to decrease the vehicle's front suspension sag with the snow plow in place. This can be accomplished with the use of supplementary air bags, booster springs, or similar load boosting devices. Since there are different load boosting devices available, it will up to the customer/end user to decide and purchase the product to suit the application, and not the responsibility of Sno-Way International, Inc.

ASSEMBLY TOOLS NEEDED

Drill Bits	1/4" - 1/2", 21/32" & 5/8"
Impact Sockets	7/16" – 1-3/8", 18mm
Wrenches	7/16" – 1-3/8", 18mm
Torque Wrench	
Center Punch and Hammer	
Clamping Device ("C" or bar type)	
Rat Tail Pry Bar	
Hacksaw	
Torx Bits	VT25, VT27

INSTALLATION NOTES

1. **Unless otherwise specified, mount all Subframe Components to vehicle before tightening any hardware.**
2. **It is recommended that LOCTITE®, or similar thread locking product, be used on ALL mounting hardware (i.e. Nuts, Cap Screws, Bolts, etc.).**
3. Vehicle should be parked on a level surface with a normal vehicle load on the FRONT suspension.
4. Items in parentheses () refer to quantity required for this step. Items in parentheses with a pound sign (#) indicate the part number as found in the parts list on the last page of this document.
 Example: (2) 5/8"-11 x 4-1/2" Cap Screws (#7).
5. It maybe necessary to relocate license plate holder. Check state and local laws for placement, if needed.

bumper support brackets with (2) 1/2" x 1-1/2" Cap Screws (#9), (4) 1/2" Flat Washers (#11), and (2) 1/2" Nylock Nuts (#6) provided. Flat Washers are used on both the bolt and the nut side. Through the center slot use the previously removed bumper bracket bolts to attach. On vehicles for early 1997 and prior, secure the last hole with (2) 1/2" x 4-1/2" Cap Screws (#10), (4) 1/2" Flat Washers (#11), and (2) 1/2" Nylock Nuts (#6). Flat washers used on both bolt and nut sides. For later 1997 and newer vehicles the hole will not be used.

NOTE: The following vehicles will require a Spacer (#14) between the rear holes of the Left and Right Hand Brackets and the vehicle frame: (see figure 1)

- Vehicles of less that 8800lbs GVWR
- Vehicles of 8800 lbs GVWR or greater manufactured before April 1996
- 4x2 Vehicles

MOUNTING INSTRUCTIONS

NOTE: Front air dam can be modified to clear Subframe by cutting dam to allow clearance for nose of Sub-frame.

1. If vehicle is equipped with lower valance panel, the corners may need to be removed. If so, measure 1/2" ahead of rear face of vehicle front cross member, and scribe a line across panel to a point 2-3/4" inside of inner side of frame rail. Cut off previously marked corners of the lower valance panel.

NOTE: The procedure in Step 2 should allow the Sub-frame to be installed without removing the front-bumper.

2. On one side remove the two front bumper bolts and the stud plate from the bumper. In the top front hole insert a 1/2" bolt (not supplied) and tighten securely with a standard nut. One of the existing vehicle bumper bolts will replace this 1/2" bolt after the Subframe is installed. Repeat this procedure for the other side.
3. Attach (2) Side Mounting Plates (#2) to the outside of the frame, one on each side, also reinstalling the

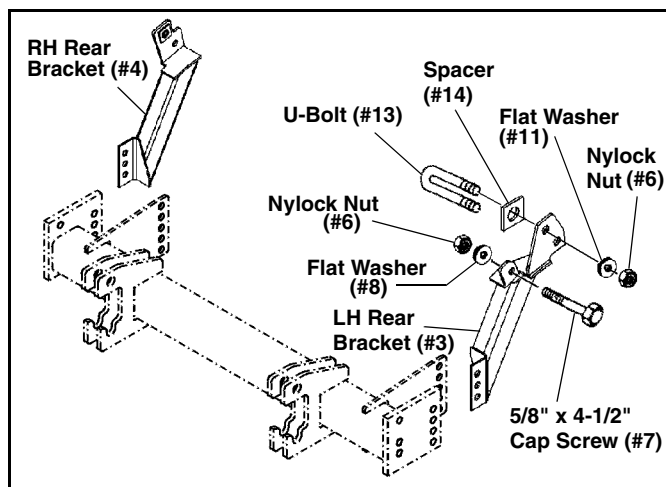

Figure 1

NOTE: Installation of Item #3 in some applications may be difficult, so extra time and drilling may be needed.

4. Position the LH Side Bracket (#3) to align the mounting holes.
 - Front holes: An existing hole for a 5/8" Cap Screw will be present. On some vehicles the power steering pump mounting bolt can be used. On other vehicles a small existing hole will be present. If this occurs, use the hole in the bracket as a template to drill out the hole in the vehicle frame to 21/32". (See figure 2)
 - Rear holes: One of the two rear holes should align with a 1" hole in the vehicle frame rail. On some models there is no 1" hole to accommodate the U-Bolt (#13). If this happens, use the Side Bracket as a template to drill a 5/8" hole in the vehicle frame.

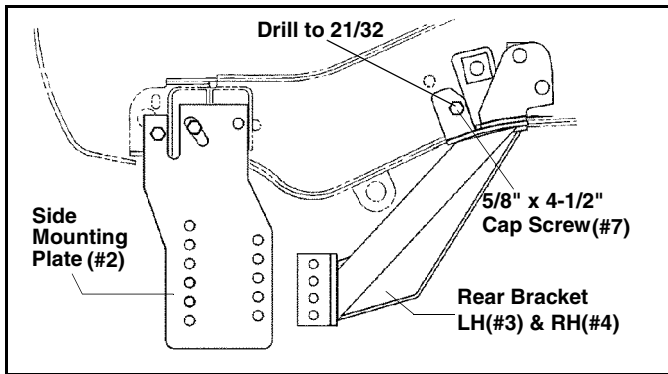

Figure 2

5. Secure (1) LH Rear Bracket Assembly (#3) to the vehicle frame with (1) 1/2" U-Bolt (#13). Loop the 1/2" U-Bolt through the 1" holes in the outer face of the vehicle frame. (Hint: To insure the bolt does not fall into the frame hold it in place with a rubber band). Position the two back holes of the rear bracket over the U-Bolt. Secure with (2) 1/2" Flat Washers (#11) and (2) 1/2" Nylock Nuts (#6). Hold the Rear Bracket tight to the bottom of the vehicle frame and push towards the rear of the vehicle. Tighten bolts. Secure the front hole with (1) 5/8" x 4 1/2" Cap Screw (#7), (1) 5/8" Flat Washer, and (1) 5/8" Nylock Nut (#12).
6. Position the RH Rear Bracket Assembly (#4) to check the mounting alignment. (See step 4 if holes need to be drilled). Loop the 1/2" U-Bolt through the 1" Holes in the outer face of the frame. (Again, secure with a rubber band to insure U-Bolt doesn't fall into frame). Position the bracket over the U-Bolt. Secure with (2) 1/2" Flat Washers (#11) and 1/2" Nylock Nuts (#6).

NOTE: Be sure to keep components parallel to ground when performing the following steps.

7. Attach (1) Mounting Assembly (#1) to the Side Mounting Plates (#2) using (8) 1/2" x 2" Cap Screws (#5) (4 on each side), (6) 1/2" Nylock Nuts (#6). (3 on each side- 2 holes in mounting assembly are threaded.)
8. Secure the RH and LH Rear Brackets (#3 and #4) to the Mounting Assembly (#1) using (4) 1/2" x 2" Cap Screws (#5) (2 on each bracket).

NOTE: (4x2 only) If height is less than 9" an air adjustable suspension or other lift accessory must be installed to increase height to specification shown.

9. After all components have been installed tighten hardware in the following order to specifications found

in the Torque Specification Chart.

- A. Tighten the bolts attaching the Rear Brackets (#3 and #4) to the vehicle frame.
 - B. Tighten all the bolts that secure the Mounting Assembly to the Rear Brackets and Side Mounting Plates.
 - C. Tighten bolts that secure the Side Mounting Plates to the frame.
10. Replace the 1/2" bolts installed in step 2 with the existing bumper bolts. Tighten to manufacturers specifications.

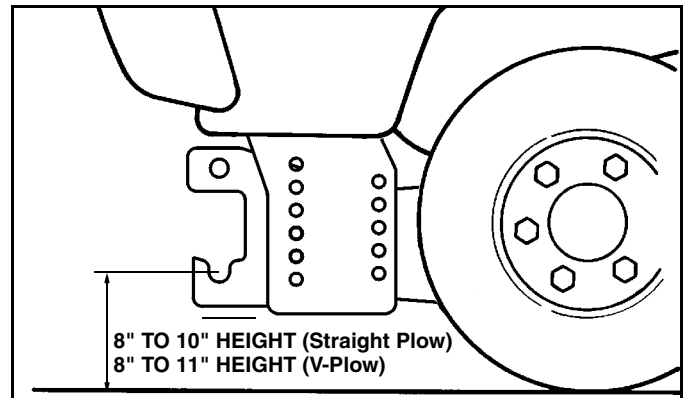

Figure 3

IMPORTANT: Height from the center of the lower Plow Mounting holes on the Subframe to the ground should be between 8" and 10" for Straight Plows, and between 8" and 11" for V-Plows to insure proper operation.

NOTE: (4x2 Only) If height is less than 9" an air-adjustable suspension kit or other lift accessory **must** be installed to increase the height to the specifications shown.

TORQUE SPECIFICATIONS FOR STANDARD MACHINE HARDWARE					
Bolt Size	GR.2 Dry	GR.5 Dry	GR.8 Dry	Metric Size	GR.8.8 Dry
1/4"	66*	9	12	M8	17
5/16"	11	17	25	M10	35
3/8"	20	30	45	M12	60
7/16"	32	50	70	M14	95
1/2"	50	75	110	M16	155
9/16"	70	110	150		
5/8"	100	150	220		
3/4"	175	260	380		
7/8"	170	430	600		
1"	250	640	900		

Note: These torque values are to be used for all hardware. Unless otherwise specified, all torque values must meet this specification.
Note: All torque values are in Ft.-Lbs unless otherwise stated
Note: *In-Lbs

REMEMBER After 5 to 10 hours of snowplow usage, re-torque all Cap Screws!

PARTS LIST

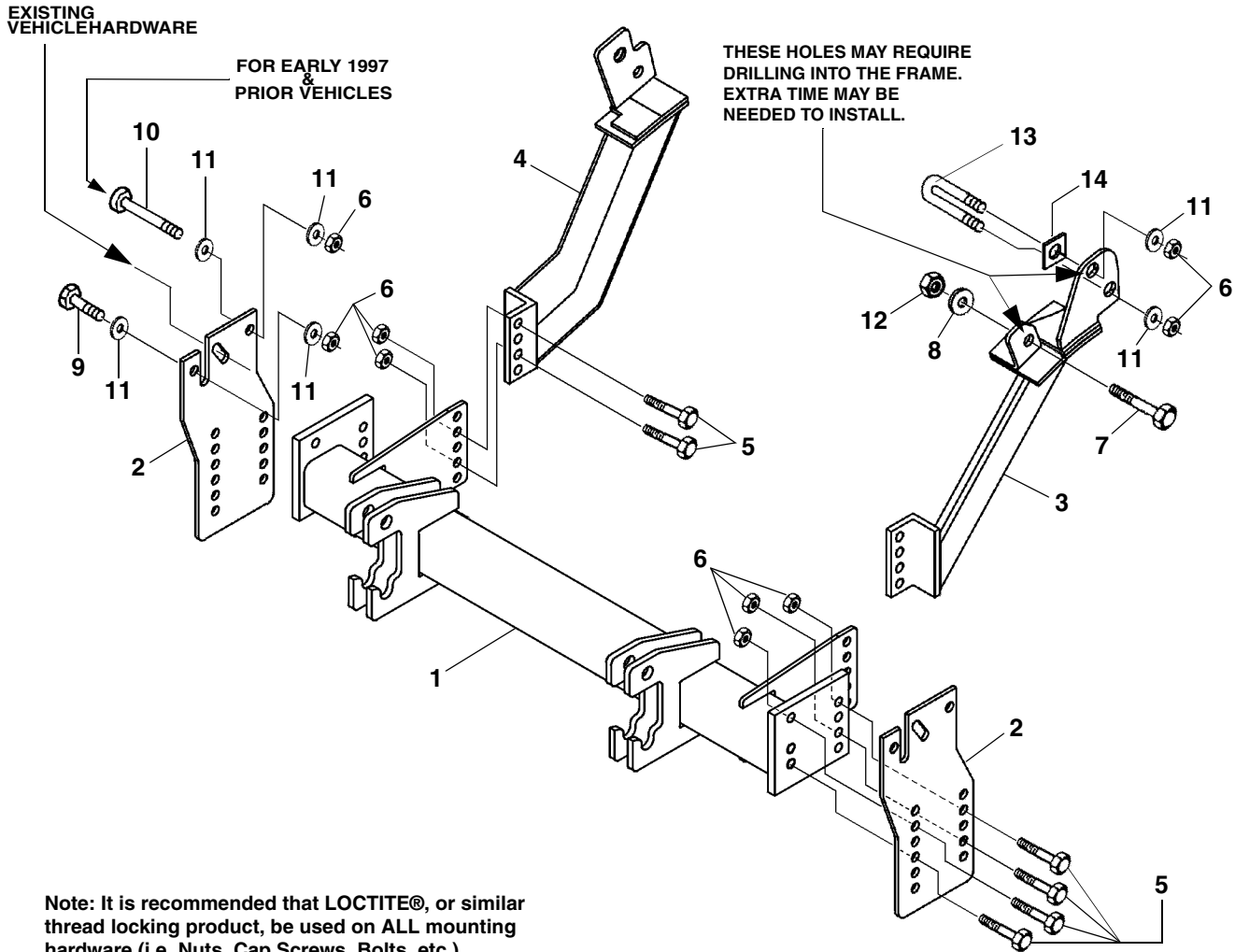

Note: It is recommended that LOCTITE®, or similar thread locking product, be used on ALL mounting hardware (i.e. Nuts, Cap Screws, Bolts, etc.).

ITEM	PART NO.	DESCRIPTION	QTY.
1	96107779*	Mounting Assembly	1
2	96104985*	Mounting Plate, Side	2
3	96104993*	Rear Bracket, LH Assembly	1
4	96104996*	Rear Bracket, RH Assembly	1
5	98100094	Cap Screw, Hex Head, 1/2"-13 NC x 2"	12
6	98009013	Nut, Hex, 1/2"-13 NC Nylock	18
7	98009111	Cap Screw, Hex Head 5/8"-11 x 4 1/2"	1
8	98009039	Washer, Flat, 5/8"	1
9	98009010	Cap Screw, Hex Head, 1/2"-13 x 1-1/2"	2
10	98009055	Cap Screw, Hex Head, 1/2"-13 x 4-1/2"	2
11	98009011	Washer, Flat, 1/2"	12
12	98009038	Nut, Hex, 5/8"-11 NC Nylock	1
13	98100271	U-Bolt, 1/2"	2
14	96102702*	Spacer	2

* Not Available As a Service Part

SNO-WAY® INTERNATIONAL, INC.

SNO-WAY
SNOW & ICE CONTROL EQUIPMENT

Hartford, WI 53027 USA
Website: www.snoway.com
©2007 Sno-Way® International