

SNO-WAY[®]

SNOW & ICE CONTROL EQUIPMENT

Assembly & Installation Instructions

**FOR
SUBFRAME COMPONENTS PACKAGE 99100781**

TO FIT

1999 - LATER Chevrolet 2500 Silverado (4X4)

1999 - LATER GM 2500 Sierra (4X4)

1999 - LATER Chevrolet K3500 Pickup (4X4)

1999 - LATER GM K3500 Pickup (4X4)



1. THINK SAFETY, ALWAYS WEAR SAFETY GLASSES WHEN PERFORMING THE OPERATIONS PRESCRIBED IN THESE INSTRUCTIONS
2. READ ALL INSTRUCTIONS CAREFULLY BEFORE ATTEMPTING INSTALLATION
3. BEFORE BEGINNING WORK MAKE SURE TO SET PARKING BRAKE AND CHOCK



MINIMUM VEHICLE RECOMMENDATIONS

- Heavy Duty Alternator
- Heavy Duty Battery
- Manufacturers Snow Plow Package
- Air-adjustable Suspension Kit

ASSEMBLY TOOLS NEEDED

- Drill Bits 1/4", 17/32" and 21/32"
- Impact Sockets 7/16" – 1-3/8"
- Impact Sockets, Metric 10mm – 18mm
- Wrenches 7/16" – 1-3/8"
- Wrenches, Metric 10mm - 18mm
- Torque Wrench
- Rat Tail Pry Bar
- Center Punch and Hammer

INSTALLATION NOTES

1. Unless otherwise specified, mount all Subframe Components to vehicle before tightening any hardware.
2. It is recommended that **LOCTITE®**, or similar thread locking product, be used on ALL mounting hardware (i.e. Nuts, Cap Screws, Bolts, etc.).
3. Vehicle should be parked on a level surface with a normal vehicle load on the FRONT suspension.
4. Items in parentheses () refer to quantity required for this step. Items in parentheses with a pound sign (#) indicate the part number as found in the parts list on the last page of this document.
Example: (2) 5/8"-11 x 1-1/2" Cap Screws (#7).
5. It maybe necessary to relocate license plate holder. Relocate under the driver's side headlight by drilling new holes in the bumper. Check state and local laws for placement, if needed.

Cap Screw (#11) and (1) 1/2" Lock Washer (#13) through the top inside hole of the Mounting Bracket and the vehicle frame upper tow hook hole into (1) Nut Plate (#17), inserted into the frame rail from the front.

The middle hole on the bottom of the frame should align with the middle hole of the Mounting Bracket flange. Using the front hole as a template, drill a 1/4" pilot hole, then drill to 21/32" through the bottom of the truck frame. Secure with (2) 5/8"-11 x 1 1/2" Cap Screws (#7) and (2) 5/8" Lock Washers (#8) into the Nut Plate (#5), which is inserted through the front of the frame rail.

Repeat procedure for the Mounting Bracket Assembly, RH (#3)

NOTE: For most applications, the tow hooks have to be left off the vehicle in order to mount the plow. In some cases, the tow hooks can be re-installed. Re-install the tow hooks, if applicable, using M12-1.25 x 40 Cap Screws (#14) in the upper holes, and M12-1.25 x 40 Cap Screws (#14) with 1/2" Lock Washers (#13) in the lower holes. (One each, per side).

MOUNTING INSTRUCTIONS

1. Remove the bumper with the air dam attached. Retain with hardware for replacement at the end of the installation. Typically, the front fascia or air dam of the vehicle will need to be modified to accommodate the Subframe.
2. Remove splash shield from underneath the vehicle. It should be possible to reinstall the splash shield on the vehicle, above the Mounting Assembly (#1). (Otherwise retain with hardware for future use.)
3. Remove the tow hooks and retain with hardware for re-installation, if applicable. (See *NOTE* following Item #4).
4. Align the top inside hole of the Mounting Bracket Assembly, LH (#2), with the existing upper tow hook hole on the inside of the vehicle frame rail, and align the rear hole in the horizontal flange of the Mounting Bracket with the existing lower tow hook hole on the bottom of the vehicle frame rail.
Install (1) 1/2"-13 x 1-1/2" Cap Screw (#11), (1) 1/2" Lock Washer (#13) and (1) 1/2" Flat Washer (#16) through the Mounting Bracket flange and bottom of frame rail into (1) Nut Plate (#17), inserted into the frame rail from the front. Install (1) 1/2"-13 x 1-1/2"

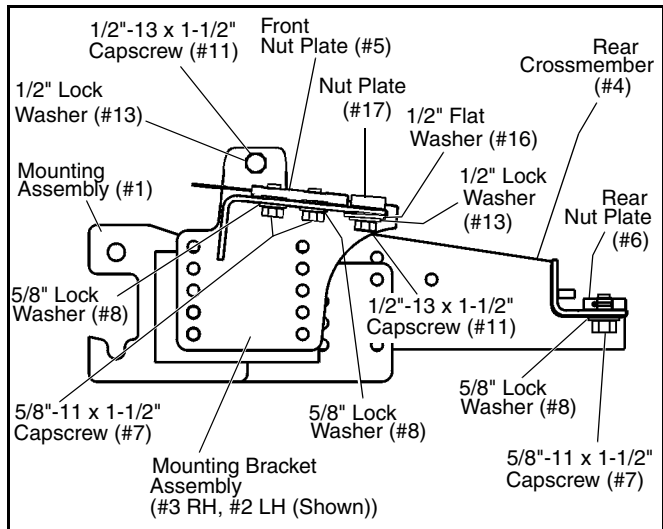

Components without tow hook re-installation.

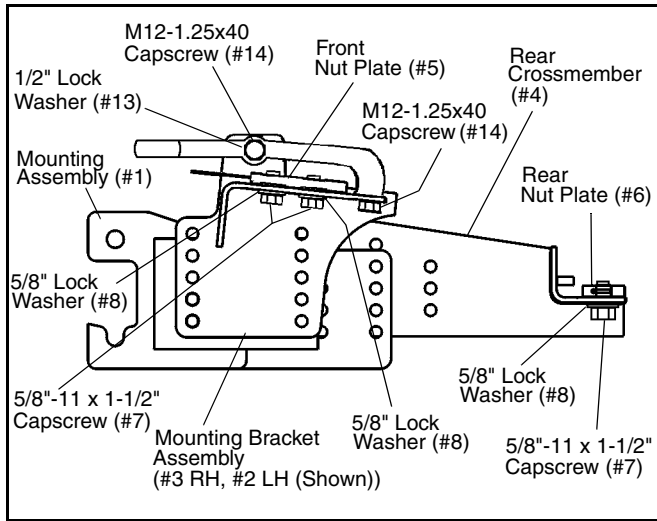

TORQUE SPECIFICATIONS FOR STANDARD MACHINE HARDWARE					
Bolt Size	GR.2 Dry	GR.5 Dry	GR.8 Dry	Metric Size	GR.8.8 Dry
1/4"	66*	9	12	M8	17
5/16"	11	17	25	M10	35
3/8"	20	30	45	M12	60
7/16"	32	50	70	M14	95
1/2"	50	75	110	M16	155
9/16"	70	110	150		
5/8"	100	150	220		
3/4"	175	260	380		
7/8"	170	430	600		
1"	250	640	900		

These torque values are to be used for all hardware. Unless otherwise specified, all torque values must meet this specification.
All torque values are in Ft.-Lbs unless otherwise stated
*In-Lbs

Components with tow hook re-installation.

- Position the Rear Crossmember (#4) under the lip of the truck's cross frame. Secure the Rear Crossmember outer holes using (2) 5/8"-11 x 1-1/2" Cap Screws (#7), (2) 5/8" Lock Washers (#8), (2) 5/8" Flat Washers (#15) and (2) Rear Nut Plates (#6) to the vehicle frame. For the inner holes use the (2) M10-1.50 x 35 Cap Screws (#9), (2) 10 mm Lock Washers (#10) and (2) 1/2" Flat washers (#16).
- Attach the Mounting Assembly (#1) to the Front Mounting Brackets (#2 & #3), using (8) 1/2"-13 x 1-1/2" Cap Screws (#11) and (6) 1/2" Nylock Nuts (#12).

NOTE: Only (6) Nylock Nuts (#12) are needed because of the threaded holes in the Mounting Assembly.

- Attach the Mounting Assembly to the Rear Crossmember (#4) using (8) 1/2"-13 x 1-1/2" Cap Screws (#11) and (8) 1/2" Nylock Nuts (#12).
- Using the Torque Specification Chart given, torque all bolts starting at the rear and working forward.
- Re-install the bumper onto the vehicle.

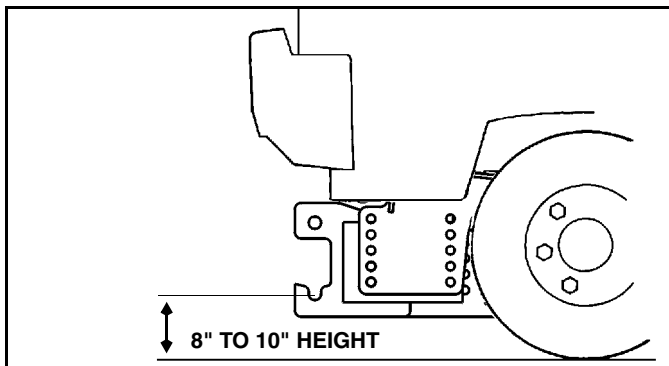

IMPORTANT: Height from the bottom of the lower pin slots on the Sub-Frame to the ground should be between 8" and 10" for proper operation.

PARTS LIST

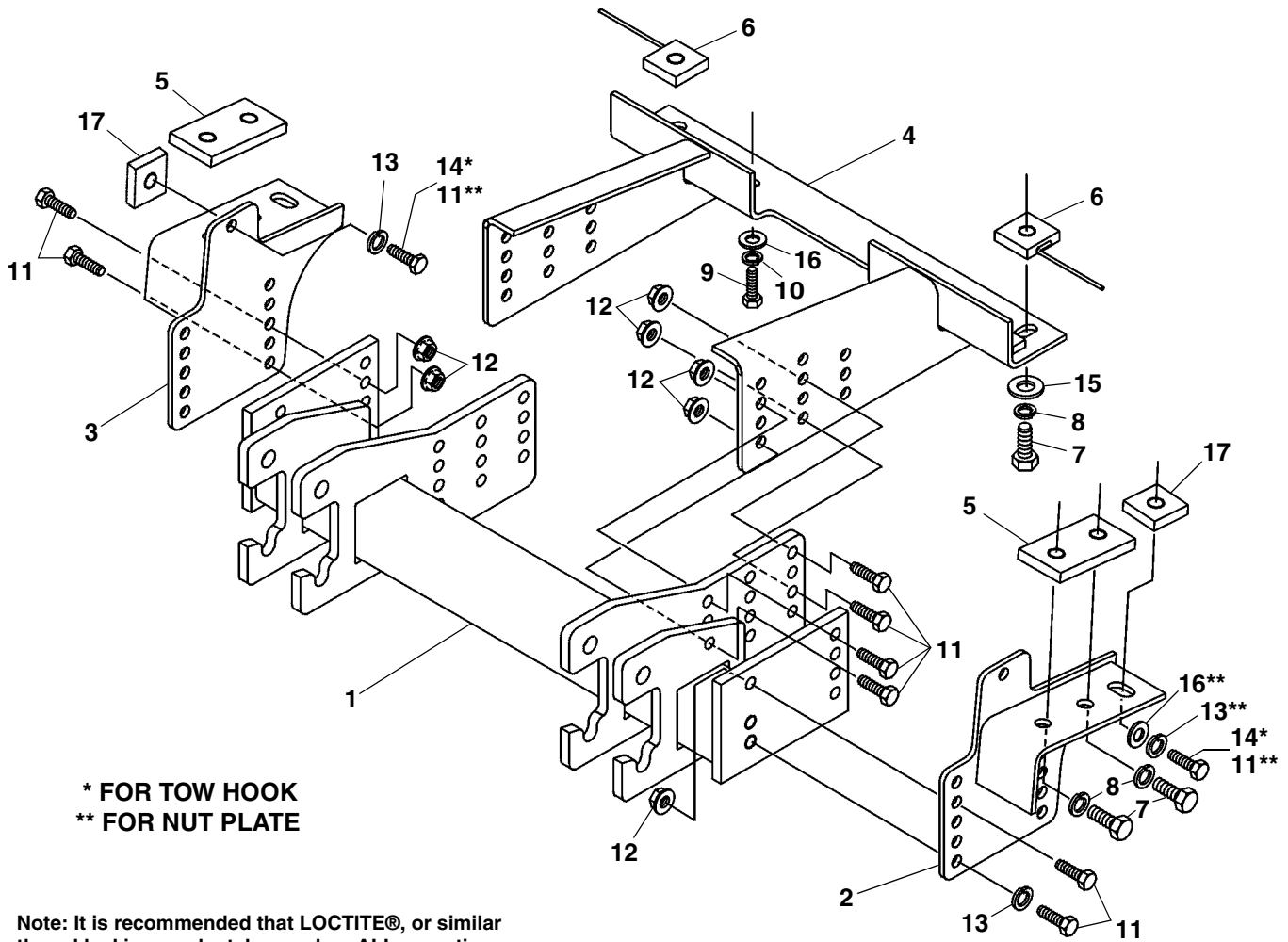

* FOR TOW HOOK
** FOR NUT PLATE

Note: It is recommended that LOCTITE®, or similar thread locking product, be used on ALL mounting hardware (i.e. Nuts, Cap Screws, Bolts, etc.).

ITEM	PART NO.	DESCRIPTION	QTY.
1	96107872	Assembly, Mounting	1
2	96107254	Assembly, Mounting Bracket, LH	1
3	96107255	Assembly, Mounting Bracket, RH	1
4	96107275	Assembly, Rear Crossmember	1
5	96103813	Plate, Nut	2
6	96103518	Assembly, Rear Nut Plate	2
7	98009115	Cap Screw, Hex Head, 5/8"-11 x 1-1/2"	6
8	98009062	Washer, Lock, 5/8"	6
9	98009060	Cap Screw, Hex Head, M10-1.50 x 35	2
10	98100048	Washer, Lock, 10mm	2
11	98009010	Cap Screw, Hex Head, 1/2"-13 x 1-1/2"	20
12	98009013	Nut, Hex, Nylock, 1/2"-13	14
13	98009012	Washer, Lock, 1/2"	6
14	98009054	Cap Screw, Hex Head, M12-1.25 x 40	4
15	98009039	Washer, Flat, 5/8"	2
16	98009011	Washer, Flat, 1/2"	4
17	96103505	Plate, Nut	4

SNO-WAY® INTERNATIONAL, INC.

SNO-WAY
SNOW & ICE CONTROL EQUIPMENT

Hartford, WI 53027 USA
Website: www.snoway.com
©2005 Sno-Way® International