

SNO-WAY®

SNOW & ICE CONTROL EQUIPMENT

ASSEMBLY & INSTALLATION INSTRUCTIONS

**VEHICLE MOUNT KIT 99100853
USING
VEHICLE CENTER MEMBER 99100890**

**TO FIT
2006-2008 DODGE RAM 1500 PICKUP 4X4
(NOT MEGA CAB)**

Sno-Way®, Down Pressure® and EIS® are registered trademarks of Sno-Way International, Inc.
ProControl™, MegaBlade™, V-Wing™, E-Z Switch™, Revolution™, MaxAdjust™, SpeedLock™, and QuickJack™
are trademarks of Sno-Way International, Inc.

©2019 Sno-Way® International

97101222C



1. **THINK SAFETY, ALWAYS WEAR SAFETY GLASSES WHEN PERFORMING THE OPERATIONS PRESCRIBED IN THESE INSTRUCTIONS**
2. **READ ALL INSTRUCTIONS CAREFULLY BEFORE ATTEMPTING INSTALLATION**
3. **BEFORE BEGINNING WORK MAKE SURE TO SET PARKING BRAKE AND CHOCK WHEELS**



MINIMUM VEHICLE RECOMMENDATIONS

Heavy Duty Alternator

Heavy Duty Battery

NOTE: On some vehicles it may be necessary to use a form of load booster to decrease the vehicle's front suspension sag with the snow plow in place. This can be accomplished with the use of supplementary air bags, booster springs, or similar load boosting devices. Since there are different load boosting devices available, it will up to the customer/end user to decide and purchase the product to suit the application, and not the responsibility of Sno-Way International, Inc.

ASSEMBLY TOOLS NEEDED

- Drill Bits 1/4", 17/32"
- Impact Sockets 7/16" – 1-3/8", 10mm - 18mm
- Wrenches 7/16" – 1-3/8", 10mm - 18mm
- Torque Wrench
- Rat Tail Pry Bar
- Center Punch and Hammer

INSTALLATION NOTES

1. **Unless otherwise specified, mount all Vehicle Mount Kit Components to vehicle before tightening any hardware.**
2. **It is recommended that LOCTITE®, or similar thread locking product, be used on ALL mounting hardware (i.e. Nuts, Cap Screws, Bolts, etc.).**
3. Vehicle should be parked on a level surface with a normal vehicle load on the FRONT suspension.
4. Items in parentheses () refer to quantity required for this step. Items in parentheses with a pound sign (#) indicate the part number as found in the parts list on the last page of this document.
Example: (10) Washer, Lock, 1/2" (#8).
5. It maybe necessary to relocate license plate holder. Check state and local laws for placement, if needed.

front-most drilled holes and secure with (2) 1/2" Nylock Nuts (#7). (Excess handle will need to be bent or cut out of the way in order to re-install bumper in a later step).

5. Repeat steps 2-4 for installation of the Side Weldment, RH (#3).
6. Assemble the Vehicle Center Member (#1) to the Side Weldments, LH (#2) and RH (#3), and secure with (8) 1/2"-13 x 1-1/2" Cap Screws (#6), (2) 1/2" Lock Washers (#9) through the threaded holes, and (6) 1/2" Nylock Nuts (#7).
7. Re-install the bumper.
8. Using the torque specification chart provided, torque all Cap Screws.

MOUNTING INSTRUCTIONS

1. Remove bumper and retain hardware for re-installation in a later step.
2. Install the Side Weldment, LH (#2):
To the inside of the vehicle frame, push the Side Weldment tight up against the bottom and inside of the frame rail, and align the front slots with the bumper bolt holes. Secure Side Weldment using (2) of the existing bumper bolts.
3. Using the (4) holes in the Side Weldment as a template, drill (4) 1/4" pilot holes, then drill 17/32" holes through the inner wall of the frame rail. **DO NOT DRILL THROUGH BOTH WALLS OF THE FRAME.**
4. Insert (2) Handle Bolt Weldments (#5), and (2) 1/2" Flat Washers (#8) through the front of the frame rails, out through the rear-most drilled holes, and secure with (2) 1/2" Nylock Nuts (#7). Then insert (2) Handle Bolt Weldments (#4) and (2) 1/2" Flat Washers (#8) through the front of the frame rails, out through the

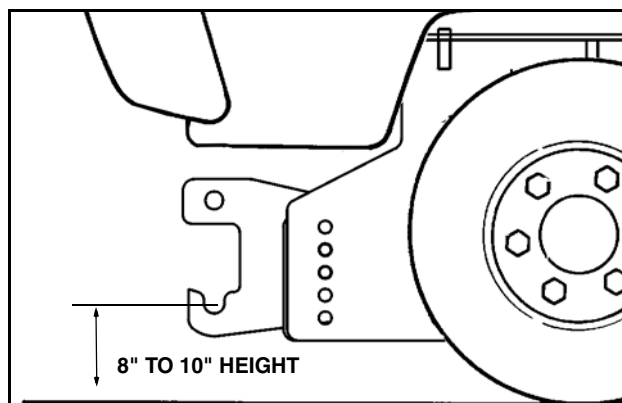

IMPORTANT: Height from the center of the lower Plow Mounting holes on the Vehicle Mount Kit to the ground should be between 8" and 10" to insure proper operation.

**TORQUE SPECIFICATIONS FOR
STANDARD MACHINE HARDWARE**

Bolt Size	GR.2 Dry	GR.5 Dry	GR.8 Dry	Metric Size	GR.8.8 Dry
1/4"	66*	9	12	M8	17
5/16"	11	17	25	M10	35
3/8"	20	30	45	M12	60
7/16"	32	50	70	M14	95
1/2"	50	75	110	M16	155
9/16"	70	110	150		
5/8"	100	150	220		
3/4"	175	260	380		
7/8"	170	430	600		
1"	250	640	900		

Note: These torque values are to be used for all hardware. Unless otherwise specified, all torque values must meet this specification.

Note: All torque values are in Ft.-Lbs unless otherwise stated

Note: *In-Lbs

**REMEMBER After 5 to 10 hours of snowplow usage,
re-torque all Cap Screws!**

PARTS LIST

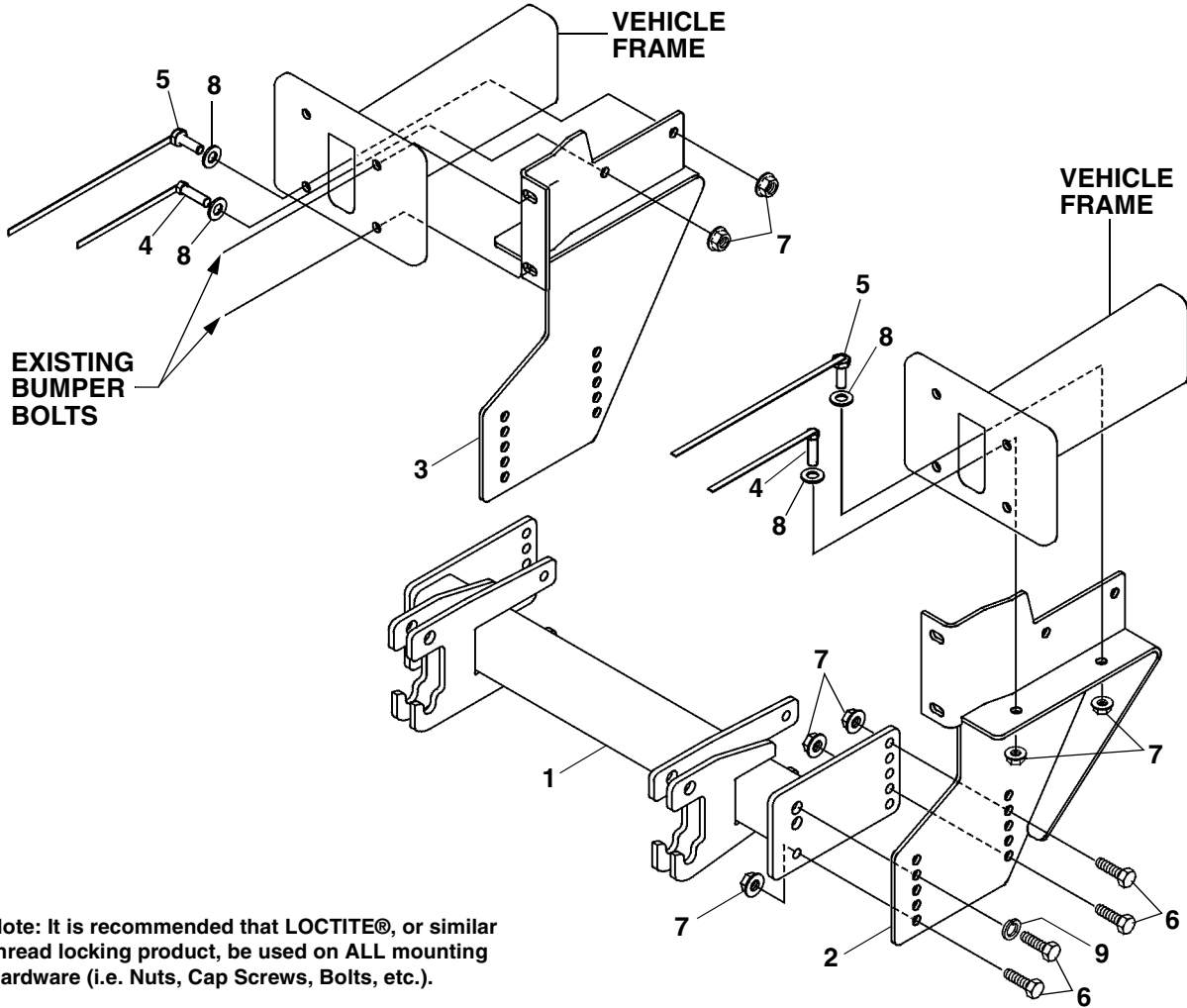

Note: It is recommended that LOCTITE®, or similar thread locking product, be used on ALL mounting hardware (i.e. Nuts, Cap Screws, Bolts, etc.).

ITEM	PART NO.	DESCRIPTION	QTY.
1	99100890	Vehicle Center Member	1
2		Side Weldment, LH	1
3		Side Weldment, RH.....	1
4		Weldment, 1/2"-13 x 1-1/4" Handle Bolt	4
5		Weldment, 1/2"-13 x 1-1/2" Handle Bolt	4
6		HHCS, 1/2"-13 x 1-1/2"	8
7		LN, 1/2"-13	14
8		PW, 1/2".....	8
9		LW, 1/2"	2
10	96109012	Kit, Hardware (Not Shown) (Includes items 4-9)	1

SNO-WAY® INTERNATIONAL, INC.



Hartford, WI 53027 USA
 Website: www.snoway.com
 ©2019 Sno-Way® International