

SNO-WAY[®]

SNOW & ICE CONTROL EQUIPMENT

**Assembly
&
Installation Instructions**

**FOR
VEHICLE MOUNT KIT 99100864
USING
VEHICLE CENTER MEMBER 99100891**

**TO FIT
1992 - 1998 Ford 4X4 F250 HD & F350 & F350 Chassis Cab**



1. **THINK SAFETY, ALWAYS WEAR SAFETY GLASSES WHEN PERFORMING THE OPERATIONS PRESCRIBED IN THESE INSTRUCTIONS**
2. **READ ALL INSTRUCTIONS CAREFULLY BEFORE ATTEMPTING INSTALLATION**
3. **BEFORE BEGINNING WORK MAKE SURE TO SET PARKING BRAKE AND CHOCK WHEELS**



MINIMUM VEHICLE RECOMMENDATIONS

- Heavy Duty Front Springs
- Heavy Duty Battery
- Heavy Duty Alternator
- Manufacturer's Snow Plow Package

NOTE: On some vehicles it may be necessary to use a form of load booster to decrease the vehicle's front suspension sag with snow plow in place. This can be accomplished with the use of supplementary air bags, booster springs, or similar load boosting devices. Since there are different load boosting devices available, it will be up to the customer/end user to decide and purchase the product to suit the application, and not the responsibility of Sno-Way International, Inc.

NOTE: On some vehicles, the anti-sway bar must be removed in order to install the Vehicle Mount Kit. Retain with hardware if the Vehicle Mount Kit is removed from the vehicle. It is important that the anti-sway bar be re-installed if the Vehicle Mount Kit is removed.

ASSEMBLY TOOLS NEEDED

- Impact Sockets 7/16" – 1-3/8"
- Metric Sockets 10 mm – 19 mm
- Wrenches 7/16" – 1-3/8"
- Metric Wrenches 10 mm – 19 mm
- Drill Bits 1/4", 13/32" & 17/32"
- Torque Wrench
- Center Punch
- Hammer
- Rat Tail Pry Bar

INSTALLATION NOTES

1. **Unless otherwise specified, mount all Vehicle Mount Kit Components to vehicle before tightening any hardware.**
2. **It is recommended that LOCTITE®, or similar thread locking product, be used on ALL mounting hardware (i.e. Nuts, Cap Screws, Bolts, etc.).**
3. Vehicle should be parked on a level surface with a normal vehicle load on the FRONT suspension.
4. Items in parentheses () refer to quantity required for this step. Items in parentheses with a pound sign (#) indicate the part number as found in the parts list on the last page of this document.
Example: (2) 5/8" x 1-1/2" Cap Screws (#9).
5. It may be necessary to relocate license plate holder. Check state and local laws for placement, if needed.

2. Insert (1) Bolt Weldment (#19) inside the frame rail on both left and right hand sides. Install (1) Bracket, LH (#17) and (1) Bracket, RH (#18) using (2) 3/8" Flat Washers (#20) and (2) 3/8" Nylock Nuts (#21) on both sides of the frame.

NOTE: If mounting to slots, push Crossmember Front Weldment forward to the front of the slots. It may be necessary to use (2) Shim Plates (#7) between the vehicle frame and the Crossmember Front Weldment.

3. From under vehicle frame, raise (1) Crossmember Front Weldment (#2) to align with existing holes (or slots) in vehicle frame. Secure using (2) 3/4" x 1-3/4" Cap Screws (#10), (2) 3/4" Flat Washers (#15), and (2) 3/4" Nylock Nuts (#16). Clamp in place so that the bottom edge of the Crossmember Front Weldment is parallel to the ground. Remaining holes will be dealt with in later steps.
4. Attach Vehicle Center Member (#1) to the side plate of the Crossmember Front Weldment (#2) in the front set of vertical holes and secure using (6) 1/2" x 2" Cap Screws (#13) and (2) 1/2" Nylock Nuts (#12).

MOUNTING INSTRUCTIONS

1. Remove vehicle front bumper. Retain, with hardware for replacement at end of installation.



WARNING

Beware of brake and fuel lines secured to inside wall of frame rails when drilling holes in vehicle frame!

FAILURE TO HEED CAN RESULT IN INJURY OR DEATH!

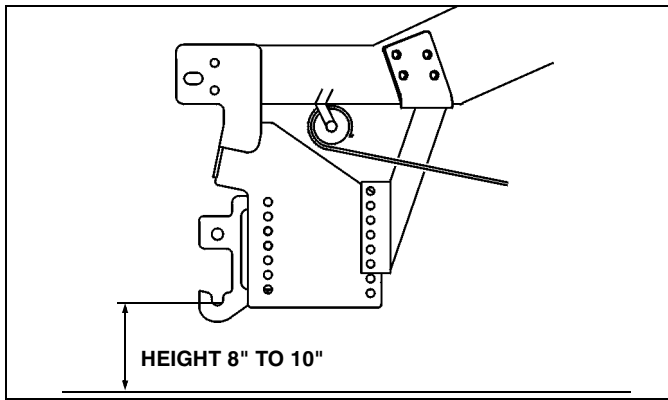

IMPORTANT: Height from the center of the lower plow mounting holes on the sub-frame to the ground should be between 8" and 10" to insure proper operation.

- Align holes in (1) Rear Mtg Weldment, (#3) RH and (#4) LH, with the back set of vertical holes on the Crossmember Front Weldment. Secure using (4) 1/2" x 2-1/4" Cap Screws (#14) and (4) Nylock Nuts (#12).

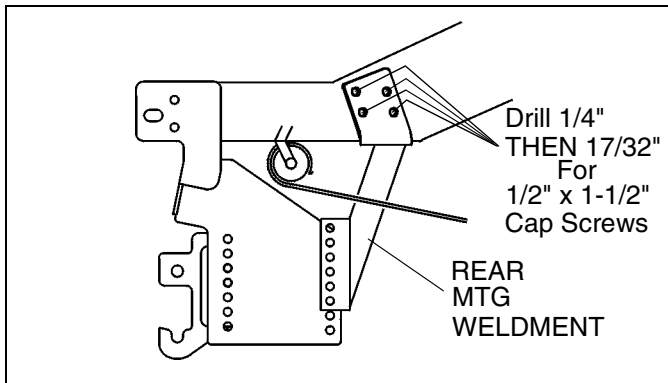

- Clamp upper leg of the Rear Mtg Weldments to the vehicle frame. Adjust the position to avoid interference with steering components, and away from the radiator (on diesel models), making sure that the bottom of the "L" shaped bracket is butted up to the bottom of the frame. This may eliminate the ability to use the existing slot on some models. Using holes in the Rear Mtg Weldments as a template, center punch, and drill 1/4", then 17/32" holes through the outer wall of the vehicle frame.
- Using (8) 1/2" x 1-1/2" Cap Screws (#8), (8) 1/2" Lock Washers (#9) and (4) Plate Nut Weldments (#5 RH & #6 LH), secure Rear Mtg Weldments to the vehicle frame with wire handles facing the front of the vehicle.
- Using the remaining holes in the Crossmember Front Weldment as a template, center punch and drill 1/4" and then 17/32" holes through the vehicle frame rail. Secure Crossmember Front Weldment using (4) 1/2" x 1-1/2" Cap Screws (#8) and on the engine side (4) 1/2" Flat Washers (#11) and (4) 1/2" Nylock Nuts (#12).

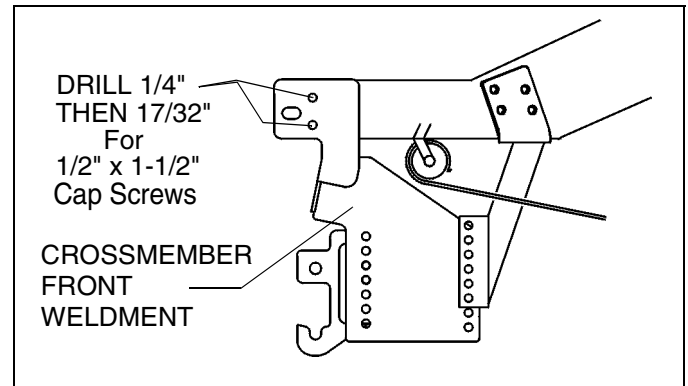

- Using the Torque Specification Chart below, torque all bolts starting at the rear and working forward.

TORQUE SPECIFICATIONS FOR STANDARD MACHINE HARDWARE					
Bolt Size	GR.2 Dry	GR.5 Dry	GR.8 Dry	Metric Size	GR.8.8 Dry
1/4"	66*	9	12	M8	17
5/16"	11	17	25	M10	35
3/8"	20	30	45	M12	60
7/16"	32	50	70	M14	95
1/2"	50	75	110	M16	155
9/16"	70	110	150		
5/8"	100	150	220		
3/4"	175	260	380		
7/8"	170	430	600		
1"	250	640	900		

Note: These torque values are to be used for all hardware. Unless otherwise specified, all torque values must meet this specification.
 Note: All torque values are in Ft.-Lbs unless otherwise stated
 Note: *In-Lbs

REMEMBER After 5 to 10 hours of snowplow usage, re-torque all Cap Screws!

- Replace the vehicle front bumper.

PARTS LIST

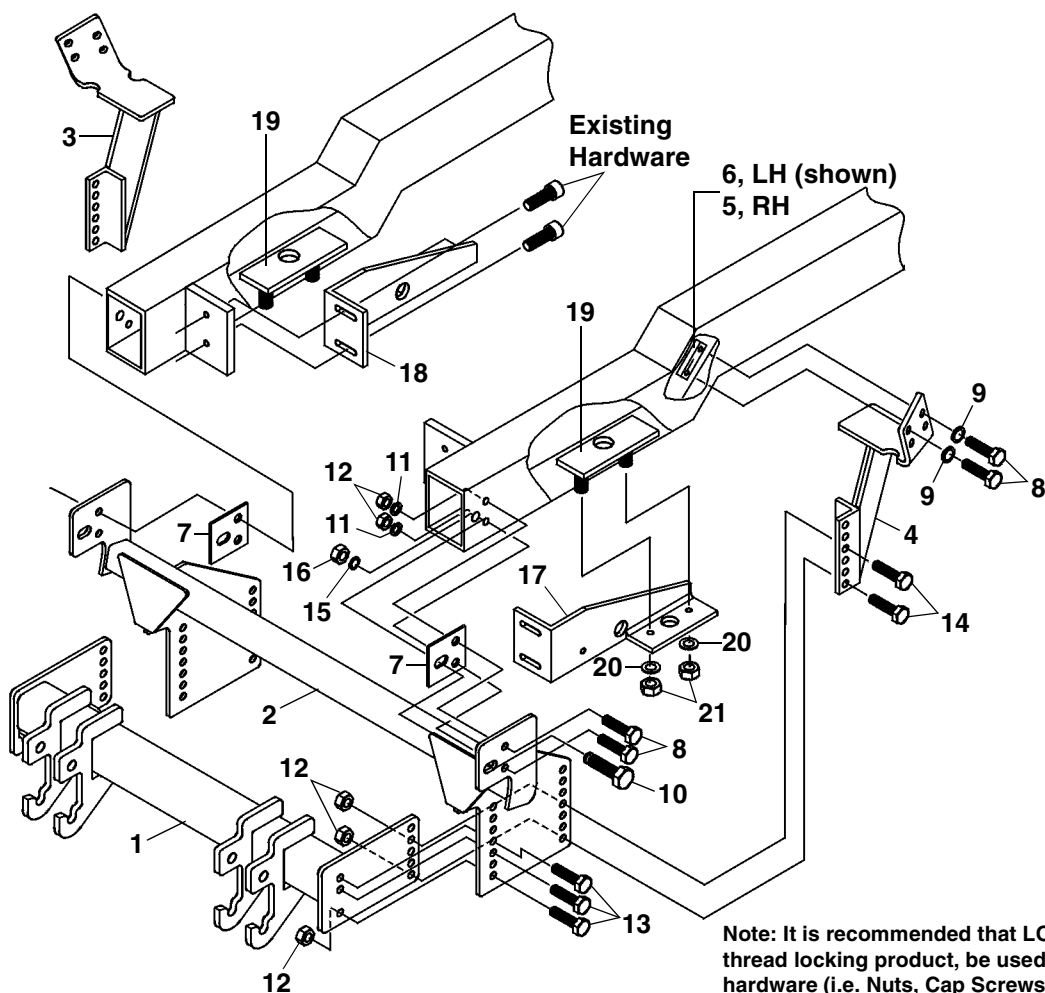

ITEM	PART NO.	DESCRIPTION	QTY.
1	99100891	Vehicle Center Member.....	1
2		Crossmember Front Weldment.....	1
3		Rear Mtg Weldment, RH.....	1
4		Rear Mtg Weldment, LH.....	1
5		Plate Nut Weldment, RH.....	2
6		Plate Nut Weldment, LH.....	2
7		Plate Shim, 5/16".....	4
8		Hex Head Cap Screw, 1/2"-13 x 1-1/2".....	12
9		Lock Washer, 1/2".....	8
10		Hex Head Cap Screw, 3/4"-10 x 1-3/4".....	2
11		Flat Washer, 1/2".....	8
12		Nylock Nut, 1/2".....	14
13		Hex Head Cap Screw, 1/2"-13 x 2".....	6
14		Hex Head Cap Screw, 1/2"-13 x 2-1/4".....	4
15		Flat Washer, 3/4".....	2
16		Nylock Nut, 3/4".....	2
17		Bracket, LH.....	1
18		Bracket, RH.....	1
19		Bolt Weldment.....	2
20		Flat Washer, 3/8".....	4
21		Nylock Nut, 3/8".....	4
22	96104547	Kit, HDWE (Includes Items 8-16, 20, 21) (Not Shown).....	1

SNO-WAY® INTERNATIONAL, INC.



Hartford, WI 53027 USA
 Website: www.snowway.com
 ©2012 Sno-Way® International