



**1. THINK SAFETY, ALWAYS WEAR SAFETY GLASSES WHEN PERFORMING THE OPERATIONS
PRESCRIBED IN THESE INSTRUCTIONS**

2. READ ALL INSTRUCTIONS CAREFULLY BEFORE ATTEMPTING INSTALLATION

**STANDARD TORQUE SPECIFICATIONS
FOR STANDARD MACHINE HARDWARE**

Bolt Size	GR.2 Dry	GR.5 Dry	GR.8 Dry	Metric Size	GR.8.8 Dry
1/4"	66*	9	12	M8	17
5/16"	11	17	25	M10	35
3/8"	20	30	45	M12	60
7/16"	32	50	70	M14	95
1/2"	50	75	110	M16	155
9/16"	70	110	150		
5/8"	100	150	220		
3/4"	175	260	380		
7/8"	170	430	600		
1"	250	640	900		

These torque values are to be used for all hardware.
Unless otherwise specified, all torque values must
meet this specification.
All torque values are in Ft.-Lbs unless otherwise stated
*In-Lbs

MODIFIED MOUNTING INSTRUCTIONS:

- Install Front Crossmember (#2) between frame and bumper bracket. If required, place Shims (#5 & #23) between Front Crossmember and vehicle frame. Be sure to use the same type and number of shims on each side to keep Front Crossmember centered on the vehicle. Re-install the bumper brackets and the front bumper using (6) M10 x 50mm Cap Screws (#18), Lock Washers (#14) and Flat Washers (#15). Re-install the emission canister.
- Install the LH Rear Support (#4) under the left vehicle frame, immediately behind the sway bar mount. Remove two M10 screws from the underside of the frame rail (if so equipped), place the rear support under the frame and fasten with (3) M10 x 35mm Cap Screws (#13), Lock Washers (#14) and Flat Washers (#15) through the rear support, vehicle frame and weld nuts in the frame. It may be necessary to drill through the frame lip and use the metric nylock nuts (#20) provided.
- Right Side Adjustment Link Mounting.
Secure the Adjustment Link (#6) to the lower hole on the RH Rear Support (#3) using (1) 5/8" x 2-1/2" Cap Screw (#8) and (1) Nylock Nut (#9). Align the Adjustment Link with the center mounting location on the Nose Piece (#1). Place (1) spacer (#7) between the Adjustment Link and the Nose Piece, securing with (1) 5/8" x 4-1/2" Cap Screw (#11) and (1) Nylock Nut (#9).
- Left Side Adjustment Link Mounting.
Secure the Adjustment Link (#6) to the lower hole on the LH Rear Support (#4) using (1) 5/8" x 2-1/2" Cap Screw (#8) and (1) Nylock Nut (#9). Attach the Tube (#22) to the back hole on the Nose Piece (#1) with (1) 5/8" x 3" Cap Screw (#21) and (1) Nylock Nut (#9). Insert the 5/8" x 6" Cap Screw (#19) through the spacer (#7) and through the front Tube (#22) hole in the center mounting location on the Nose Piece, securing with (1) Nylock Nut (#9).
- Using the Torque Specification Chart provided, first torque the Nose Piece (#1) to the Front Crossmember (#2). Start by torquing the two front Cap Screws (#12) and then the two side Cap Screws (#12). Then torque the remaining Cap Screws **starting at the rear** and working forward.

Sub-Frame Instruction Supplement For Subframe Components Package 99100345

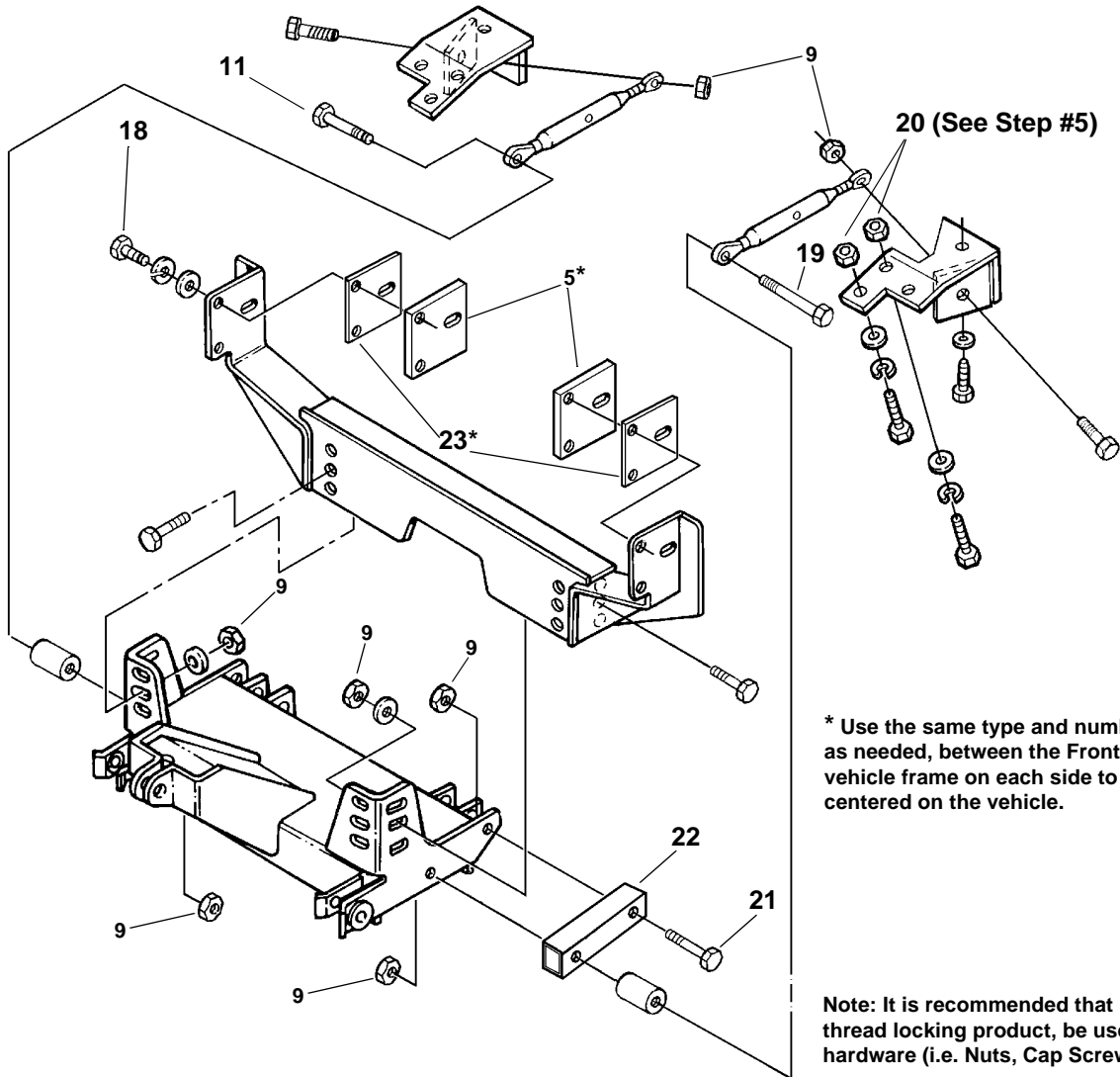

* Use the same type and number of shims (#5 & #23), as needed, between the Front Crossmember and vehicle frame on each side to keep the Nose Piece centered on the vehicle.

Note: It is recommended that LOCTITE®, or similar thread locking product, be used on ALL mounting hardware (i.e. Nuts, Cap Screws, Bolts, etc.).

ITEM	PART NO.	DESCRIPTION	QTY.
9	98009038	Nut, Hex, Nylock, 5/8"-11 NC	9
11	98009111	Cap Screw, Hex Head, 5/8"-11 NC x 4-1/2"	1
13	98009060	Cap Screw, Hex Head, M10-1.50 x 35 mm	6
18	98100198	Cap Screw, Hex Head, M10-1.50 x 50 mm	6
19	98009197	Cap Screw, Hex Head, 5/8"-11 NC x 6"	1
20	98100199	Nut, Hex, Nylock, M10-1.50	4
21	98009217	Cap Screw, Hex Head, 5/8"-11 NC x 3"	1
22	96104295	Tube	1
23	96104296	Plate, Shim, 1/4"	2

SNO-WAY® INTERNATIONAL, INC.



©1999 Sno-Way® International

97100665A