



Assembly & Installation Instructions

**FOR
SUBFRAME COMPONENTS PACKAGE 99004060
AND
SUBFRAME NOSE PIECE PACKAGE 96100694**

**TO FIT
1993 & LATER FORD 4X4 RANGER**



1. THINK SAFETY, ALWAYS WEAR SAFETY GLASSES WHEN PERFORMING THE OPERATIONS PRESCRIBED IN THESE INSTRUCTIONS
2. READ ALL INSTRUCTIONS CAREFULLY BEFORE ATTEMPTING INSTALLATION
3. BEFORE BEGINNING WORK MAKE SURE TO SET PARKING BRAKE AND CHOCK WHEELS

MINIMUM VEHICLE RECOMMENDATIONS

Heavy Duty Alternator
Heavy Duty Battery

ASSEMBLY TOOLS NEEDED

Drill Bits	1/4", 21/32"
Impact Sockets	7/16" – 1-3/8"
Wrenches	7/16" – 1-3/8"
Torque Wrench	



CAUTION

Sno-Way Does Not Recommend A Snowplow Installation On A 1995 Or Later Ford Ranger Equipped With Passenger Safety Air Bags. We Are Advised That Vehicle Crash Testing Of This Vehicle With Snowplow Packages Has Not Been Done By The Vehicle Manufacturer.

INSTALLATION NOTES

1. Unless specified, mount all Sub-Frame Components to vehicle before tightening any bolts.
2. Vehicle should be parked on a level surface with the front suspension normally loaded.

NOTE: Air Dam may be used with Plow by cutting Dam to allow clearance for nose of Sub-Frame. To modify Air Dam measures 2-7/8" from each side of center and remove a 5-3/4" deep section from between the marked areas.

MOUNTING INSTRUCTIONS

1. Remove Air Dam and fog lights from below vehicle bumper. Retain, with mounting hardware, for future use if Plow Sub-Frame is removed.

2. It may be necessary to relocate license plate holder. This is best done by aligning the plate holder below the driver's side headlight and drilling two (2) new mounting holes in the bumper.
3. Remove four (4) lower nuts from bumper mounting brackets.
4. Completing one side at a time, remove the top and bottom rear most bolts from the bumper mounting brackets and replace the upper bolt with one (1) 1/2" x 1-1/2" Capscrew (#98009010), Washer and Nylock Nut provided.
5. Align Front Crossmember (#96001777) with lower holes of bumper mounting brackets. Secure using two (2) 1/2" x 1-1/2" Capscrews (#98009010), Washers, and Nylock Nuts provided. Utilize existing flanged nuts on front two Capscrews. Use Washers (#98009011) as shims to center Front Crossmember between vehicle frame tubes.

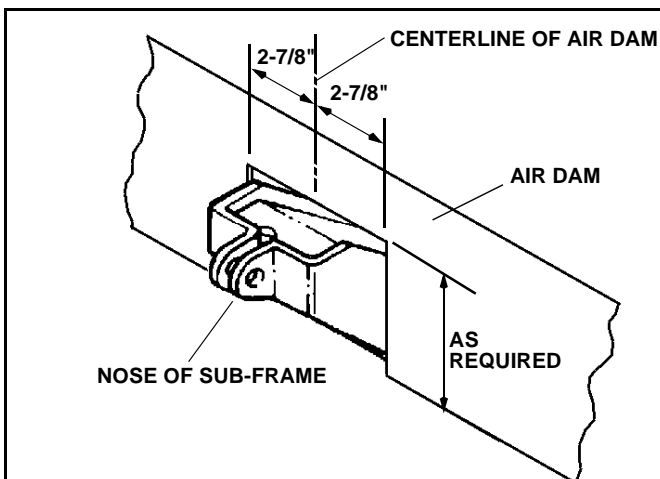

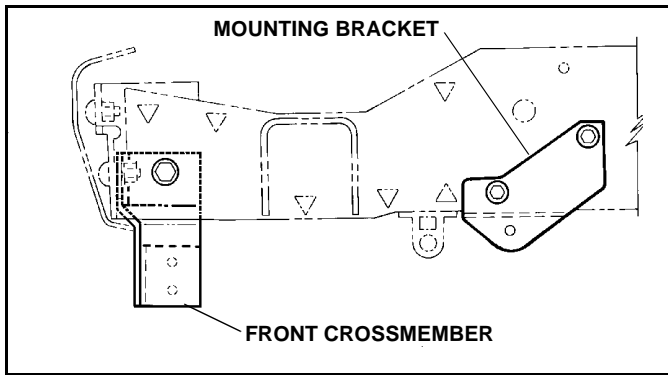

6. Remove the two lowest bolts from the vehicle's power steering gear box located in front of the left front coil spring. Install Mounting Brackets (#96100459)LH utilizing the existing hardware removed from gear box. Retorque to factory specifications.

NOTE: It is recommended that Loctite® or similar thread locking material be used when re-installing the gear box hardware.



CAUTION

Beware of brake and fuel lines secured to inside wall of frame rails when performing Step 7.

7. On passenger side of vehicle, remove nut from vertically positioned bolt located in frame tube approximately eight inches (8") behind the sway bar mount. This bolt fastens the vehicle crossmember to the frame. Align Mounting Bracket (#96100357)RH and fasten with original hardware. Using bracket as a template, drill a 1/4" pilot hole then drill to 21/64" through the inner wall of vehicle frame and secure with 5/8" x 4-1/2" Capscrew (#98009111), Washer and Nylock Nut provided.

8. Raise front of Sub-Frame Assembly (#96100294) and align mounting holes in Front Crossmember. Secure using four (4) 5/8" x 1-1/2" Capscrews (#98009115), Washers and Nylock Nuts provided.

TORQUE SPECIFICATIONS FOR STANDARD MACHINE HARDWARE					
Bolt Size	GR.2 Dry	GR.5 Dry	GR.8 Dry	Metric Size	GR.8.8 Dry
1/4"	66*	9	12	M8	17
5/16"	11	17	25	M10	35
3/8"	20	30	45	M12	60
7/16"	32	50	70	M14	95
1/2"	50	75	110	M16	155
9/16"	70	110	150		
5/8"	100	150	220		
3/4"	175	260	380		
7/8"	170	430	600		
1"	250	640	900		

Note: These torque values are to be used for all hardware. Unless otherwise specified, all torque values must meet this specification.
 Note: All torque values are in Ft.-Lbs unless otherwise stated
 Note: *In-Lbs

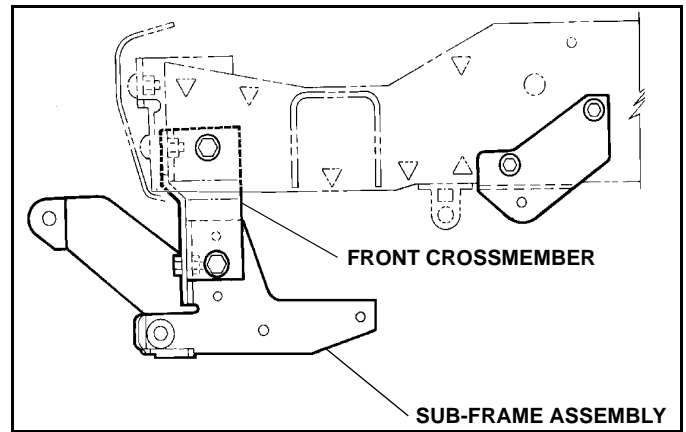

9. Install Adjustable Support Link between Mounting Brackets and between rear mounting ears on Sub-Frame Assembly as shown. Secure to Sub-Frame using 5/8" x 2-1/2" Capscrews (#98009259) and Nylock Nuts provided. Secure to lower hole in Mounting Brackets using 5/8" x 3-1/2" Capscrews (#98009042), Spacers (#96100548) and Nylock Nuts provided. (See Illustration).

10. Adjust Support Link until Sub-Frame is level with ground.

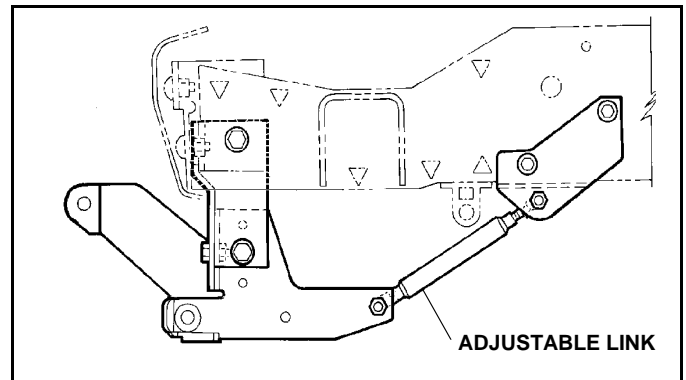

11. Using the Torque Specification Chart below, torque all bolts starting at the rear and working forward.

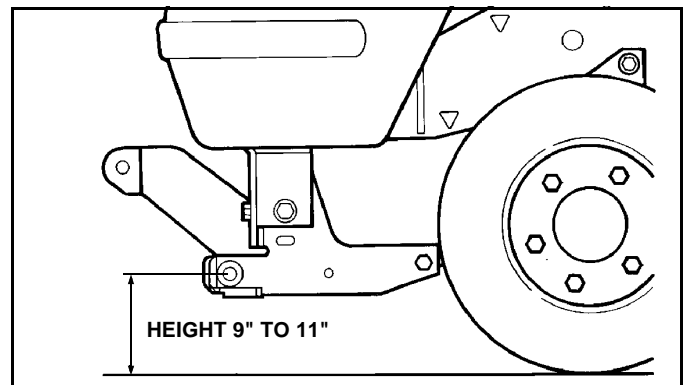

IMPORTANT: height from the center of the lower Plow Mounting holes on the Sub-Frame to the ground should be between 9" and 11" to insure proper operation.

REMEMBER After 5 to 10 hours of snowplow usage, re-torque all capscrews!

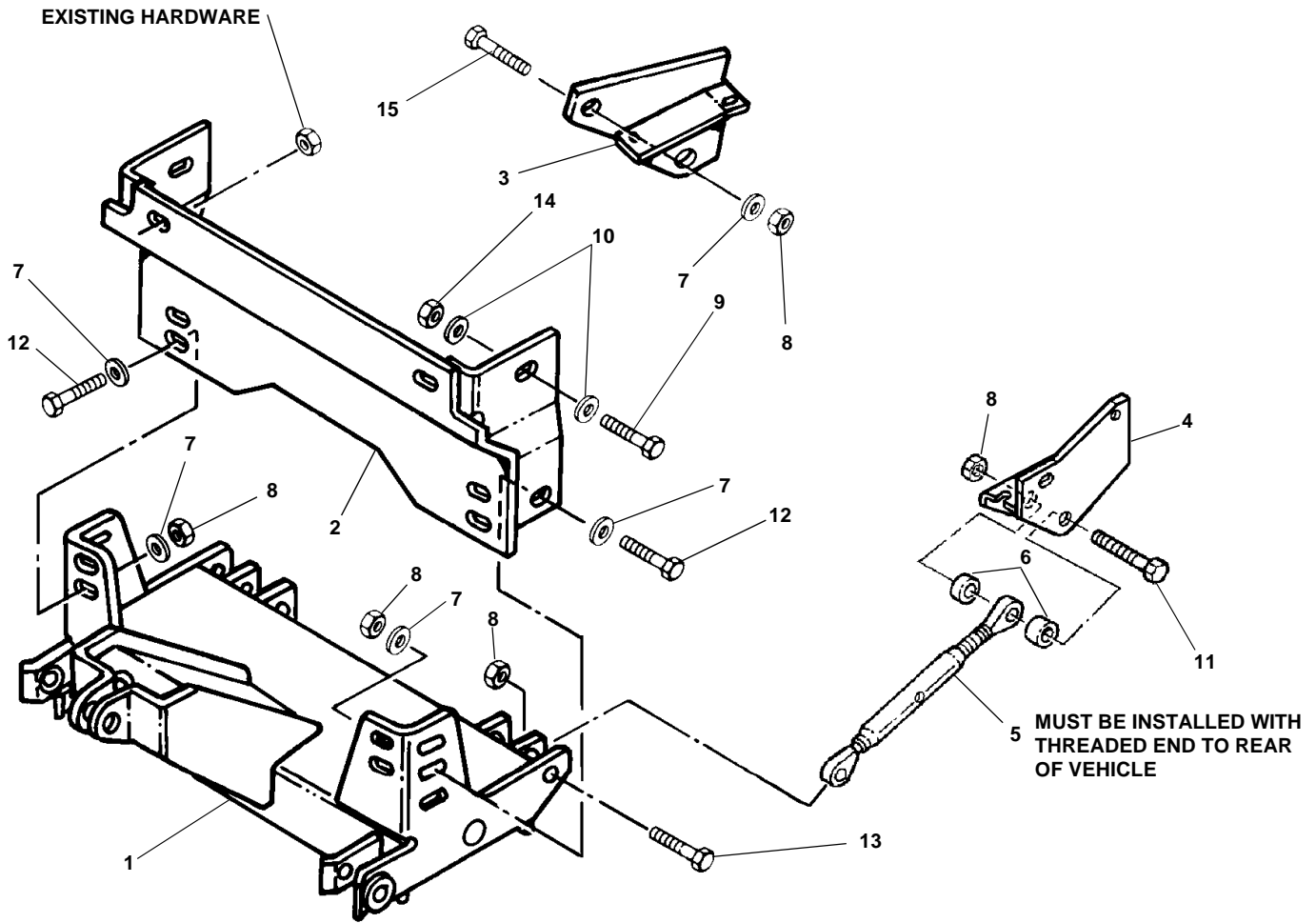

ITEM	PART NO.	DESCRIPTION	QTY.
1	96100694	Sub-Frame, Nose Piece (96100294).....	1
2	96001777	Crossmember, Front	1
3	96100357	Bracket, Mounting, RH	1
4	96100459	Bracket, Mounting, LH.....	1
5	96001831	Link, Adjustment	2
6	96100548	Spacer.....	4
7	98009039	Washer, Flat, 5/8".....	9
8	98009038	Nut, Hex, Nylock, 5/8"-11NC.....	9
9	98009010	Capscrew, Hex Head, 1/2"-13NC x 1-1/2".....	4
10	98009011	Washer, Flat, 1/2".....	8
11	98009042	Capscrew, Hex Head, 5/8"-11NC x 3-1/2".....	2
12	98009115	Capscrew, Hex Head, 5/8"-11NC x 1-1/2".....	4
13	98009259	Capscrew, Hex Head, 5/8"-11NC x 2-1/2".....	2
14	98009013	Nut, Hex, Nylock, 1/2"-13NC.....	4
15	98009111	Capscrew, Hex Head, 5/8"-11NC x 4-1/2".....	1



SNO-WAY INTERNATIONAL, INC.