



1. THINK SAFETY, ALWAYS WEAR SAFETY GLASSES WHEN PERFORMING THE OPERATIONS PRESCRIBED IN THESE INSTRUCTIONS

2. READ ALL INSTRUCTIONS CAREFULLY BEFORE ATTEMPTING INSTALLATION

ASSEMBLY TOOLS NEEDED:

- Impact Sockets 7/16"—1-3/8"
- Wrenches 7/16"—1-3/8"
- Torque Wrench
- Drills 1/4", 17/32"
- Center Punch
- Hammer
- Two 6" C-Clamps

TORQUE SPECIFICATIONS FOR STANDARD MACHINE HARDWARE					
Bolt Size	GR.2 Dry	GR.5 Dry	GR.8 Dry	Metric Size	GR.8.8 Dry
1/4"	66*	9	12	M8	17
5/16"	11	17	25	M10	35
3/8"	20	30	45	M12	60
7/16"	32	50	70	M14	95
1/2"	50	75	110	M16	155
9/16"	70	110	150		
5/8"	100	150	220		
3/4"	175	260	380		
7/8"	170	430	600		
1"	250	640	900		

NOTE: These torque values are to be used for all hardware. Unless otherwise specified, all torque values must meet this specification.
NOTE: All torque values are in Ft.-Lbs unless otherwise stated
*In-Lbs

INSTALLATION NOTES:

1. Mount Sub-Frame assembly completely before tightening any bolts unless otherwise specified.
2. To Install Sub-Frame the vehicle front suspension must be in a normal position such as when the vehicle is parked on level ground.

MOUNTING INSTRUCTIONS:

1. Align Front Crossmember (#96101552) with existing holes in bottom of frame rails. Secure using four (4) 1/2" x 1-1/2" Capscrews (#98009010), Washers, and Nylock Nuts provided.
2. Raise front of Sub-Frame Assembly (#96101547) and align mounting holes in Front Crossmember. Secure using two (2) 5/8" x 2" Capscrews (#98009041), Washers and Nylock Nuts provided.
3. Assemble Mounting Bracket (#96001212)RH, (#96001211)LH, to Sub-Frame Assembly Support Rails and secure with 5/8" (#98009038), Nylock Nuts, and Washers provided.



CAUTION

Beware of brake and fuel lines secured to inside wall of frame rails when performing Step 4.

4. Raise Sub-Frame Assembly and align Mounting Bracket with vehicle frame. Secure to frame with 6" C-Clamps. Using bracket as a template, drill four (4) 1/4" pilot holes then drill to 17/32" through the inner wall of vehicle frame and secure with four (4) 1/2" x 3-1/2" Capscrews (#98009036), Washers and Nylock Nuts provided.
5. Using the Torque Specification Chart above, torque all bolts starting at the rear and working forward.

1977—1979 FORD 4X4 F150 PICKUP & BRONCO
Sub-Frame Assembly & Installation Instructions
Part No. 99014043 Sub-Frame (Complete) Includes Hardware

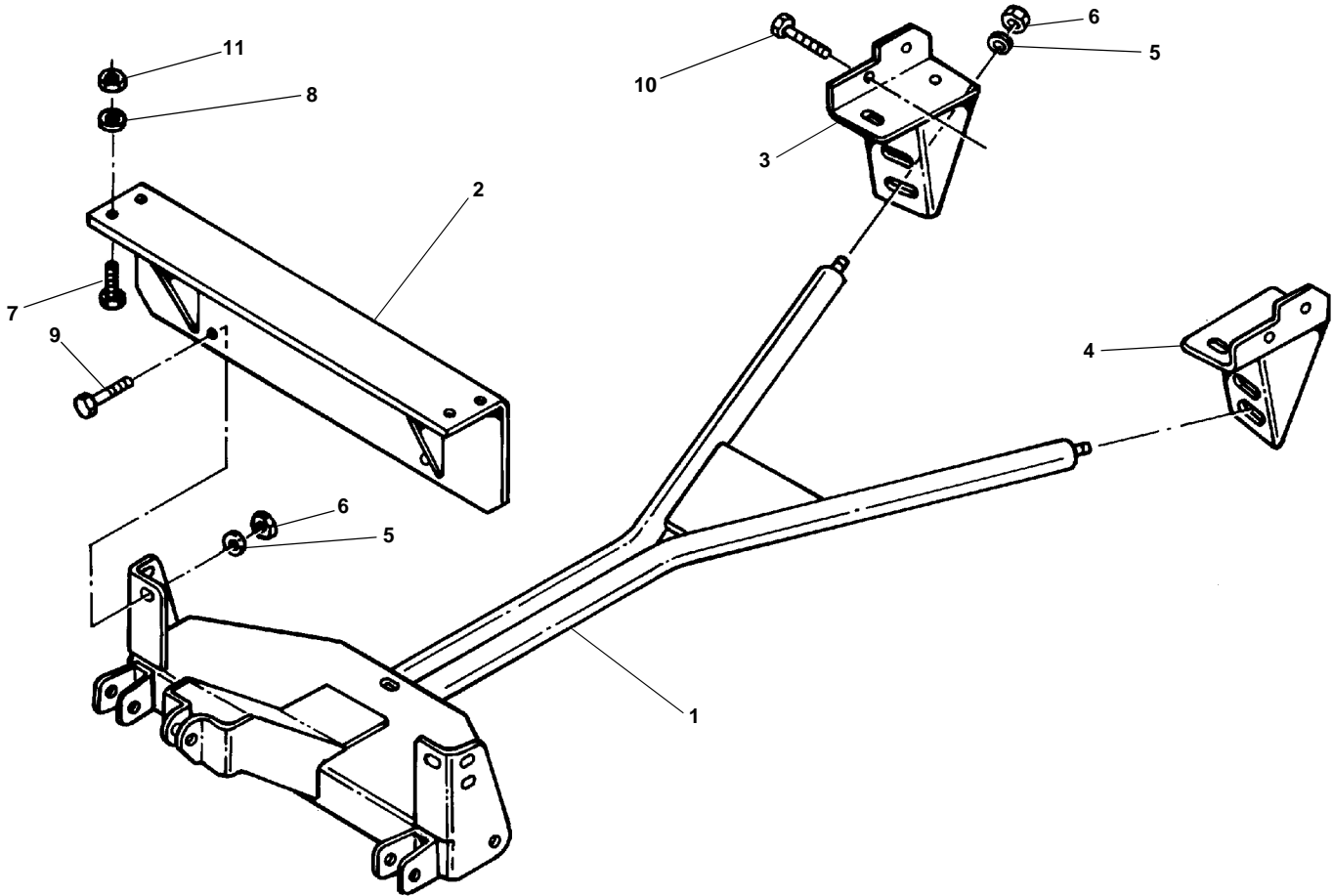

ITEM	PART NO.	DESCRIPTION	QTY.
1	96101547	Sub-Frame Assembly	1
2	96101552	Crossmember, Front	1
3	96001212	Bracket, Mounting, RH.....	1
4	96001211	Bracket, Mounting, LH	1
5	98009039	Washer, Flat, 5/8"	4
6	98009038	Nut, Hex, Nylock, 5/8"-11NC	4
7	98009010	Capscrew, Hex Head, 1/2"-13NC x 1-1/2"	8
8	98009011	Washer, Flat, 1/2"	8
9	98009041	Capscrew, Hex Head, 5/8"-11NC x 2"	2
10	98009036	Capscrew, Hex Head, 1/2"-13NC x 3-1/2"	8
11	98009013	Nut, Hex, Nylock, 1/2"-13NC	8



SNO-WAY INTERNATIONAL, INC.

97100237A