



Assembly & Installation Instructions

**FOR
SUBFRAME COMPONENTS PACKAGE 99100073
AND
SUBFRAME NOSE PIECE PACKAGE 96100694**

**TO FIT
1983 - 1991 FORD 4X4 RANGER
1983 - 1990 FORD 4X4 BRONCO II**



1. THINK SAFETY, ALWAYS WEAR SAFETY GLASSES WHEN PERFORMING THE OPERATIONS PRESCRIBED IN THESE INSTRUCTIONS
2. READ ALL INSTRUCTIONS CAREFULLY BEFORE ATTEMPTING INSTALLATION
3. BEFORE BEGINNING WORK MAKE SURE TO SET PARKING BRAKE AND CHOCK WHEELS

MINIMUM VEHICLE RECOMENDATIONS

Heavy Duty Alternator
Heavy Duty Battery

ASSEMBLY TOOLS NEEDED

Sockets	7/16" – 1-1/8"
Wrenches	7/16" – 1-1/8"
Torque Wrench	
Hacksaw	
Drill	11/16

INSTALLATION NOTES

1. Unless specified, mount all sub-frame components to vehicle before tightening any bolts.
2. Vehicle should be parked on a level surface with the front suspension normally loaded.

MOUNTING INSTRUCTIONS

1. Remove air dam from underneath vehicle. Retain, with mounting hardware, for future use if Plow Sub-Frame is removed.

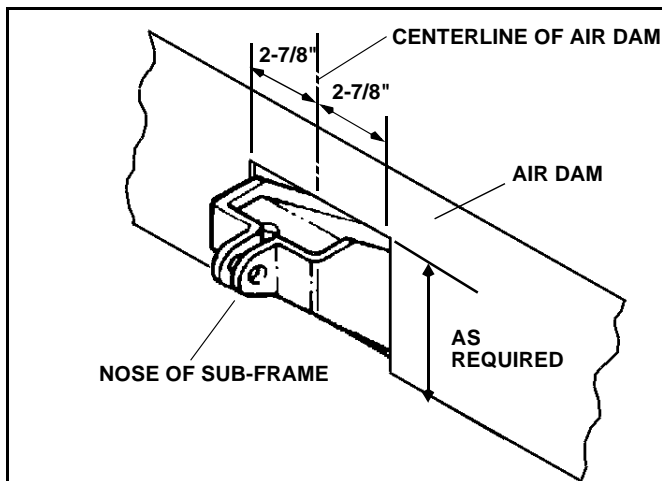

NOTE: Air dam may be used with Plow by cutting dam to allow clearance for nose of Sub-Frame. To modify Air dam measure 2-7/8" from each side and remove a 5 3/4" deep section from between the marked areas.

2. Remove the two lowest bolts from the vehicles power steering gear box (located in front of the left front coil spring). Align Rear Mounting Bracket (#96100459)LH, with existing holes and attach with existing hardware. Tighten to original Torque Specifications of 55 Ft.Lbs.

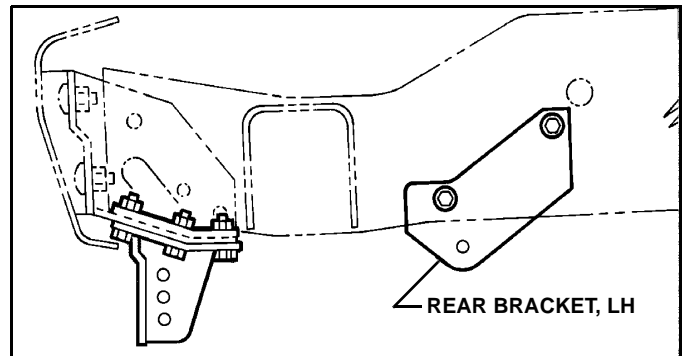

3. On passengers side of vehicle, remove nut from vertically positioned bolt located in frame tube approximately 8 inches behind the sway bar mount.
 - On STX Range Models Only, align Rear Mounting Bracket (#96100822)RH, with existing hole and attach with existing hardware. Tighten to original Torque Specification of 85 Ft.Lbs. Drill 11/16" hole using Bracket as template. Install one (1) 1/2" x 1-1/2" Cap-screw (#98009010) through drilled hole in vehicle frame and horizontal hole in Rear Mounting Bracket. Secure with Nylock Nut provided.

CAUTION

Beware of brake and fuel lines secured to inside wall of frame rails when performing Step 3.

- On all other models, align Rear Mounting Bracket (#96100357)RH with existing holes and attach with existing hardware. Tighten to original Torque Specification of 85 Ft.Lbs. Install one (1) 5/8" x 1-1/2" Cap-screw (#98009115) through slot in vehicle frame and horizontal hole in Rear Mounting Bracket. Secure with Flat Washer and Nylock Nuts provided.

4. Install Front Crossmember (#96100451) utilizing existing holes in vehicle side channels. Place Reinforcement Plate (#96100456) on inside of vehicle frame channel. Secure using six (6) 3/8" x 1-1/4" Capscrews (#98009034), Washers, and Nylock Nuts provided

NOTE: If all six (6) holes are not in vehicle frame, follow drilling procedure.

• **Drilling Procedure:** With some models, up to four (4) additional holes will be required. To locate, mount Front Crossmember in frame hole allowing 14 3/4" from the center of the Rear bracket Link Adjustment attachment hole to outside surface of Crossmember. Drill the remaining 2 holes through each end of the Front Crossmember into the frame.

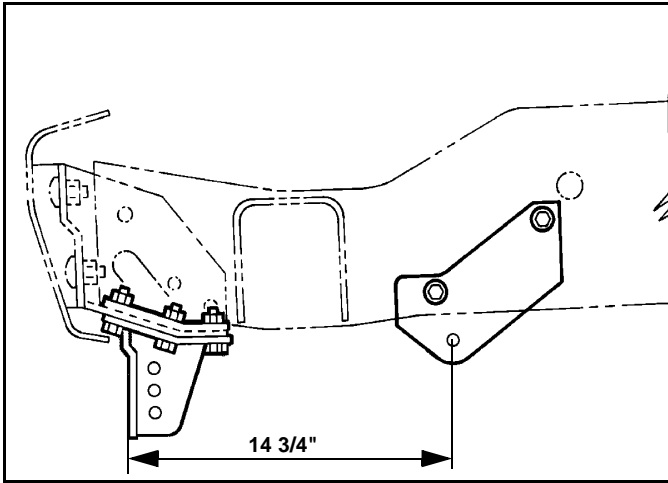

NOTE: On some models, license plate holder bracket may need to be relocated to clear Sub-Frame Assembly.

5. Raise front of Sub-Frame Assembly (96100294) and align mounting holes in Front Crossmember. Secure using four (4) 5/8" x 1-1/2" Capscrews (#98009115), Washers and Nylock Nuts Provided.

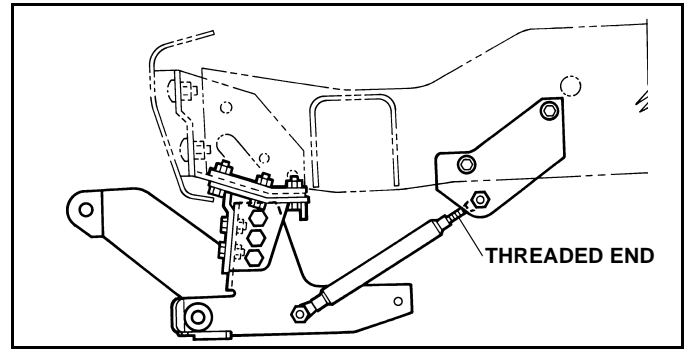

6. Install Adjustable Support Link between Rear Mounting Brackets and center mounting location on Sub-Frame Assembly Two (2) Spacers (#96100548) must be installed, one on each side of Support Link swivel, between Mounting Bracket ears as shown.

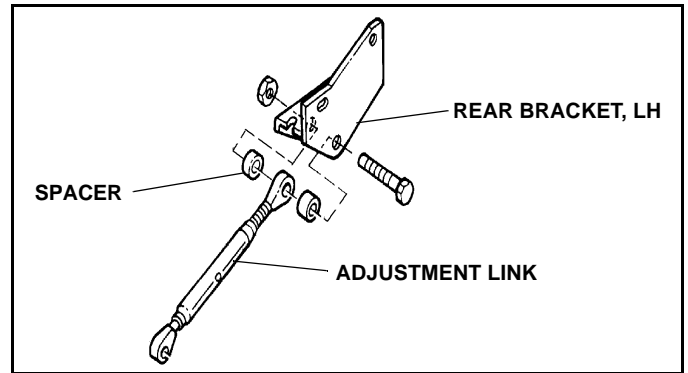

7. Secure to Sub-Frame using 5/8" x 4" Capscrews (#98009194) and Nylock Nuts provided. Secure to lower hole on Rear Brackets using 5/8" x 3 1/2" Capscrews (#98009042) and Nylock Nuts provided.

8. Adjust Support Link until Sub-Frame is level with ground.

9. Using the Torque Specification Chart, torque all Capscrews starting at the rear and working forward.

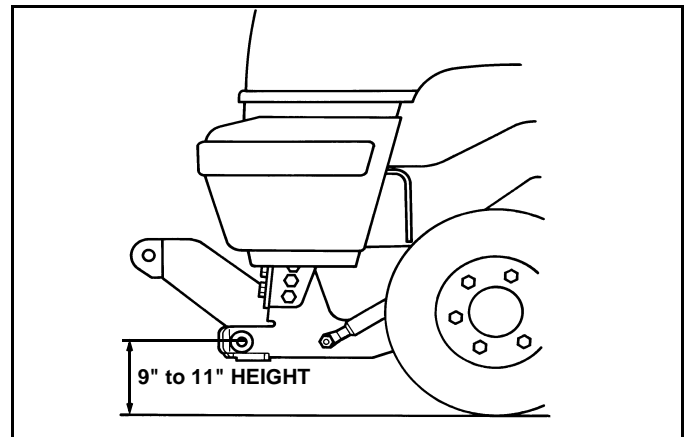

IMPORTANT: Height from the center of the lower Plow Mounting holes on the Sub-Frame to the ground should be between 9" and 11" to insure proper operation.

REMEMBER After 5 to 10 hours of snowplow usage, re-torque all capscrews!

TORQUE SPECIFICATIONS FOR STANDARD MACHINE HARDWARE					
Bolt Size	GR.2 Dry	GR.5 Dry	GR.8 Dry	Metric Size	GR.8.8 Dry
1/4"	66*	9	12	M8	17
5/16"	11	17	25	M10	35
3/8"	20	30	45	M12	60
7/16"	32	50	70	M14	95
1/2"	50	75	110	M16	155
9/16"	70	110	150		
5/8"	100	150	220		
3/4"	175	260	380		
7/8"	170	430	600		
1"	250	640	900		

Note: These torque values are to be used for all hardware. Unless otherwise specified, all torque values must meet this specification.
 Note: All torque values are in Ft.-Lbs unless otherwise stated
 Note: *In-Lbs

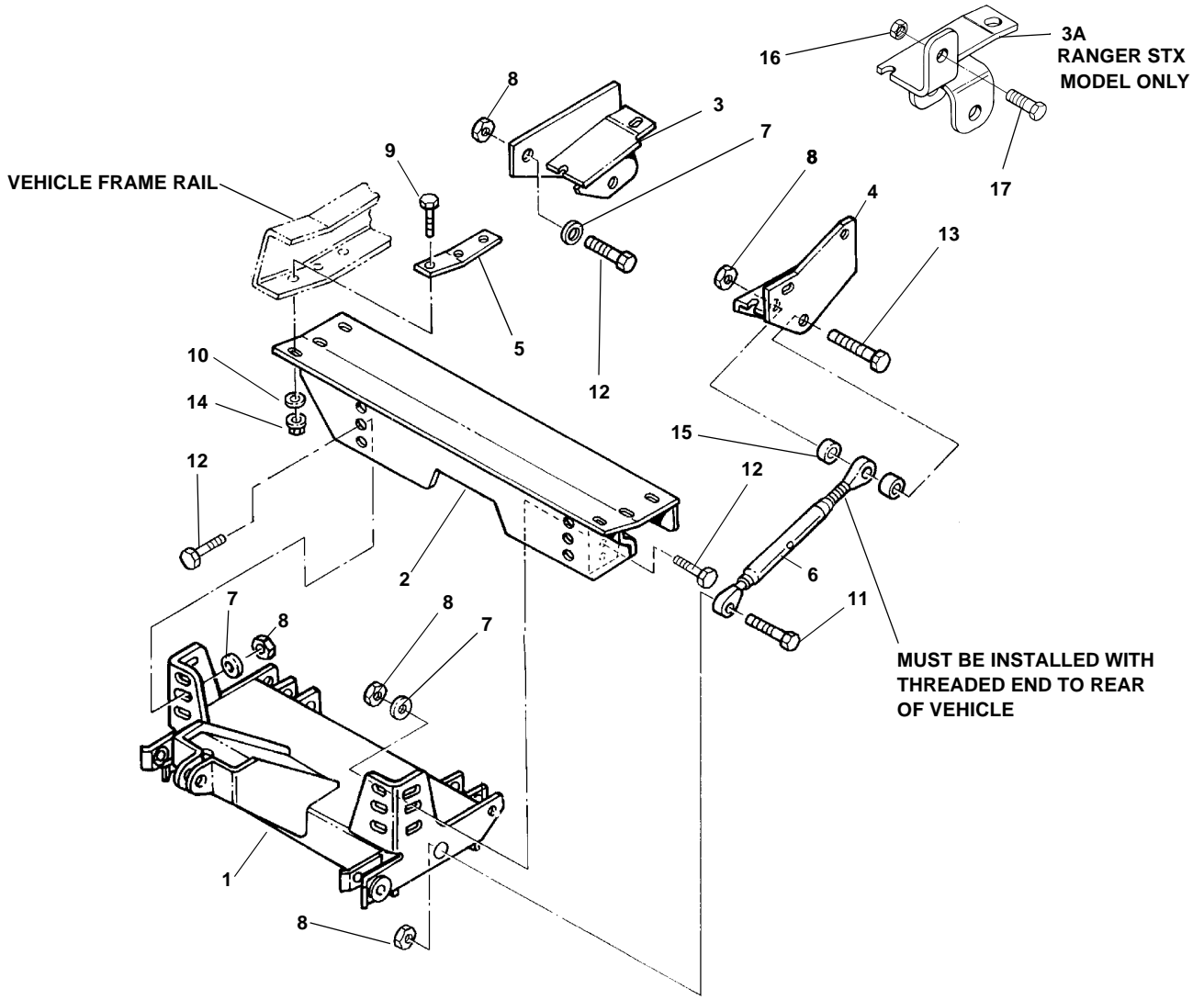

ITEM	PART NO.	DESCRIPTION	QTY.
1	96100694	Sub-Frame Nose Piece (96100294)	1
2	96100451	Crossmember, Front	1
3	96100357	Bracket, Rear, RH	1
3A	96100822	Bracket, Rear, RH (RANGER STX Models 1986-91)	1
4	96100459	Bracket, Rear, LH	1
5	96100456	Plate, Reinforcement	2
6	96001831	Link, Adjustment	2
7	98009039	Washer, Flat, 5/8"	5
8	98009038	Nut, Hex, Nylock, 5/8"-11NC	9
9	98009034	Capscrew, Hex Head, 3/8"-16NC x 1-1/4"	6
10	98009032	Washer, Lock, 3/8"	6
11	98009194	Capscrew, Hex Head, 5/8"-11NC x 4"	2
12	98009115	Capscrew, Hex Head, 5/8"-11NC x 1-1/2"	5
13	98009042	Capscrew, Hex Head, 5/8"-11NC x 3-1/2"	2
14	98009009	Nut, Hex, Nylock, 3/8"-13NC	6
15	96100548	Spacer	4
16	98009013	Nut, Hex, Nylock, 1/2"-13NC	1
17	98009010	Capscrew, Hex Head, 1/2"-13NCx1-1/2"	1



SNO-WAY INTERNATIONAL, INC.