



Assembly & Installation Instructions

**FOR
SUB-FRAME COMPONENTS PACKAGE 99100076
AND
SUBFRAME NOSE PIECE PACKAGE 96100694**

TO FIT

**1983 - 1993 CHEVROLET 4X4 S-SERIES PICKUP
1983 -1993 GMC 4X4 S-SERIES PICKUP
1983 - 1994 CHEVROLET 4X4 S-SERIES BLAZER
1983 - 1994 GMC 4X4 S-SERIES JIMMY**

97100225B



- 1. THINK SAFETY, ALWAYS WEAR SAFETY GLASSES WHEN PERFORMING THE OPERATIONS PRESCRIBED IN THESE INSTRUCTIONS**
- 2. READ ALL INSTRUCTIONS CAREFULLY BEFORE ATTEMPTING INSTALLATION**
- 3. BEFORE BEGINNING WORK MAKE SURE TO SET PARKING BRAKE AND CHOCK WHEELS**

MINIMUM VEHICLE RECOMMENDATIONS

Heavy Duty Alternator
Heavy Duty Battery
"ZM6" or "F60" suspension

ASSEMBLY TOOLS NEEDED

Sockets 7/16" – 1-1/8"
Wrenches 7/16" – 1-1/8"
Torque Wrench
Hacksaw

INSTALLATION NOTES

- Unless specified, mount all Sub-Frame Components to vehicle before tightening any bolts.
- Vehicle should be parked on a level surface with the front suspension normally loaded.

NOTE: Tow hooks may be re-installed over Front Crossmember.

NOTE: It is recommended that Loctite® or similar thread locking material be used on the 3/8" Capscrews during installation.

MOUNTING INSTRUCTIONS

- Remove air dam from front of vehicle. (Retain with hardware for future use).
- Remove front splash guard, vehicle skid plate and tie down/tow hook brackets, if so equipped. Retain hardware for installation of Front and Rear Crossmember. Retain splash guard and skid plate for reinstallation if Plow is removed.
- Install Front Crossmember (#96100460) utilizing existing location and hardware from splash guard on inside holes. Use four (4) 3/8" x 1-1/4" Capscrews (#98009034), Washers, Lockwashers and threaded Reinforcement Plates (#96100465) on outside holes of Front Crossmember (through holes in vehicle frame formerly used for tow hooks).

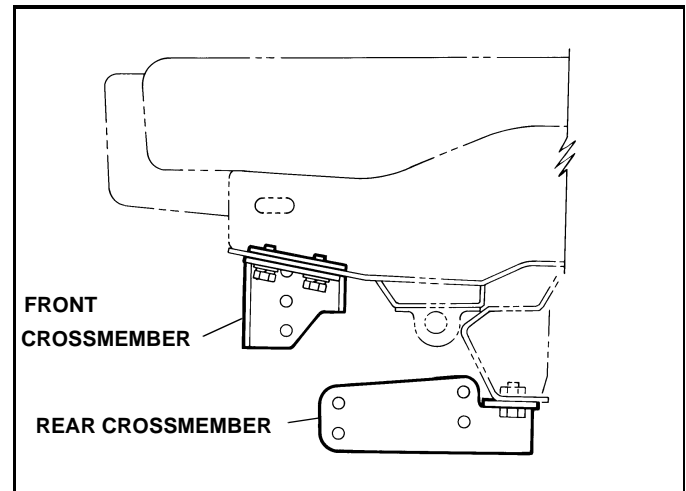

- Install Rear Crossmember (#96100466) utilizing existing location and hardware from skid plate on two outside holes, see illustration. In center hole of Rear Crossmember use one (1) 5/8" x 4-1/2" Capscrews (#98009111), Washer and Nylock Nut provided.

5. Raise Sub-Frame Assembly (#96100294) to Front Crossmember and secure with four (4) 5/8" x 1-1/2" Capscrews (#98009115) Washers, and Nylock Nuts provided.

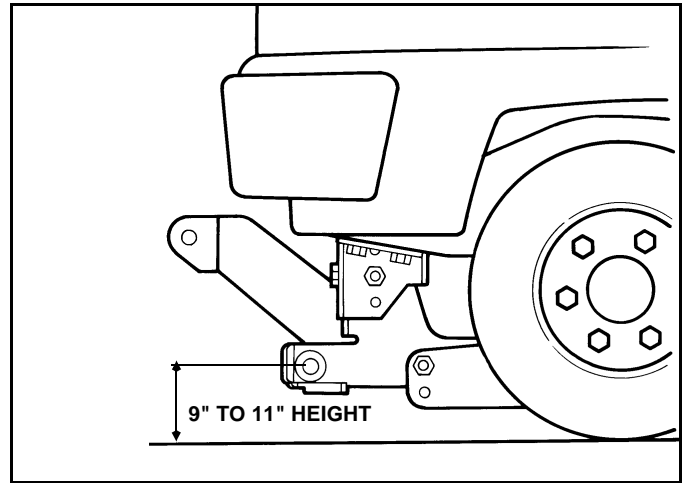
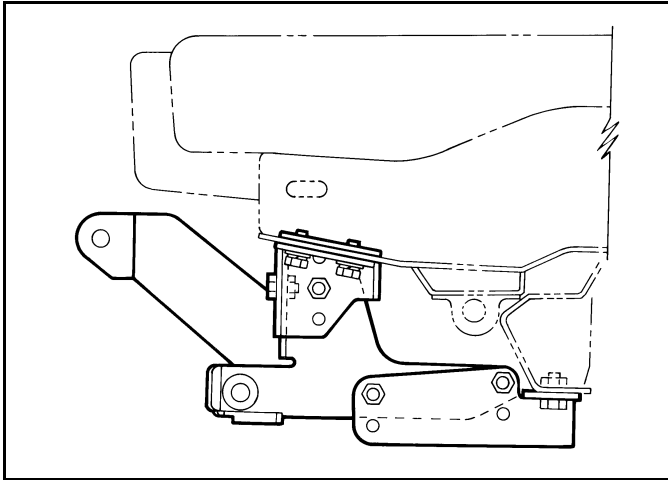

IMPORTANT: Height from the center of the lower Plow Mounting holes on the Sub-Frame to the ground should be between 9" and 11" to insure proper operation.

6. Secure Sub-Frame Assembly to Rear Crossmember using two (2) 5/8" x 3" Capscrews (#98009217) in center hole of Sub-Frame Assembly and two (2) 5/8" x 1-1/2" Capscrews (#98009115) in rear mounting holes, see illustration. Use Nylock Nuts provided to secure Capscrews.

REMEMBER After 5 to 10 hours of snowplow usage, re-torque all Capscrew!

7. Using the Torque Specification Chart below, torque all bolts starting at the rear and working forward.

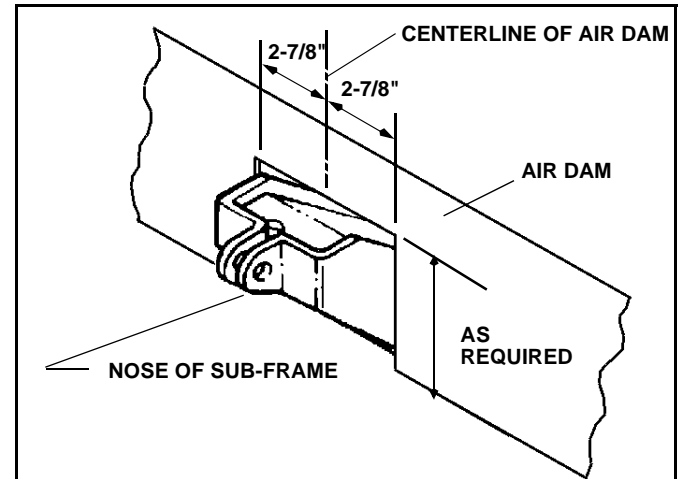

TORQUE SPECIFICATIONS FOR STANDARD MACHINE HARDWARE					
Bolt Size	GR.2 Dry	GR.5 Dry	GR.8 Dry	Metric Size	GR.8.8 Dry
1/4"	66*	9	12	M8	17
5/16"	11	17	25	M10	35
3/8"	20	30	45	M12	60
7/16"	32	50	70	M14	95
1/2"	50	75	110	M16	155
9/16"	70	110	150		
5/8"	100	150	220		
3/4"	175	260	380		
7/8"	170	430	600		
1"	250	640	900		

Note: These torque values are to be used for all hardware. Unless otherwise specified, all torque values must meet this specification.
 Note: All torque values are in Ft.-Lbs unless otherwise stated
 Note: *In-Lbs

NOTE: Front air dam can be modified to clear subframe by cutting dam to allow clearance for nose of Subframe. To modify air dam measure 2-7/8" from each side of center and remove a section as required from between the marked areas to provide clearance for nose of subframe.

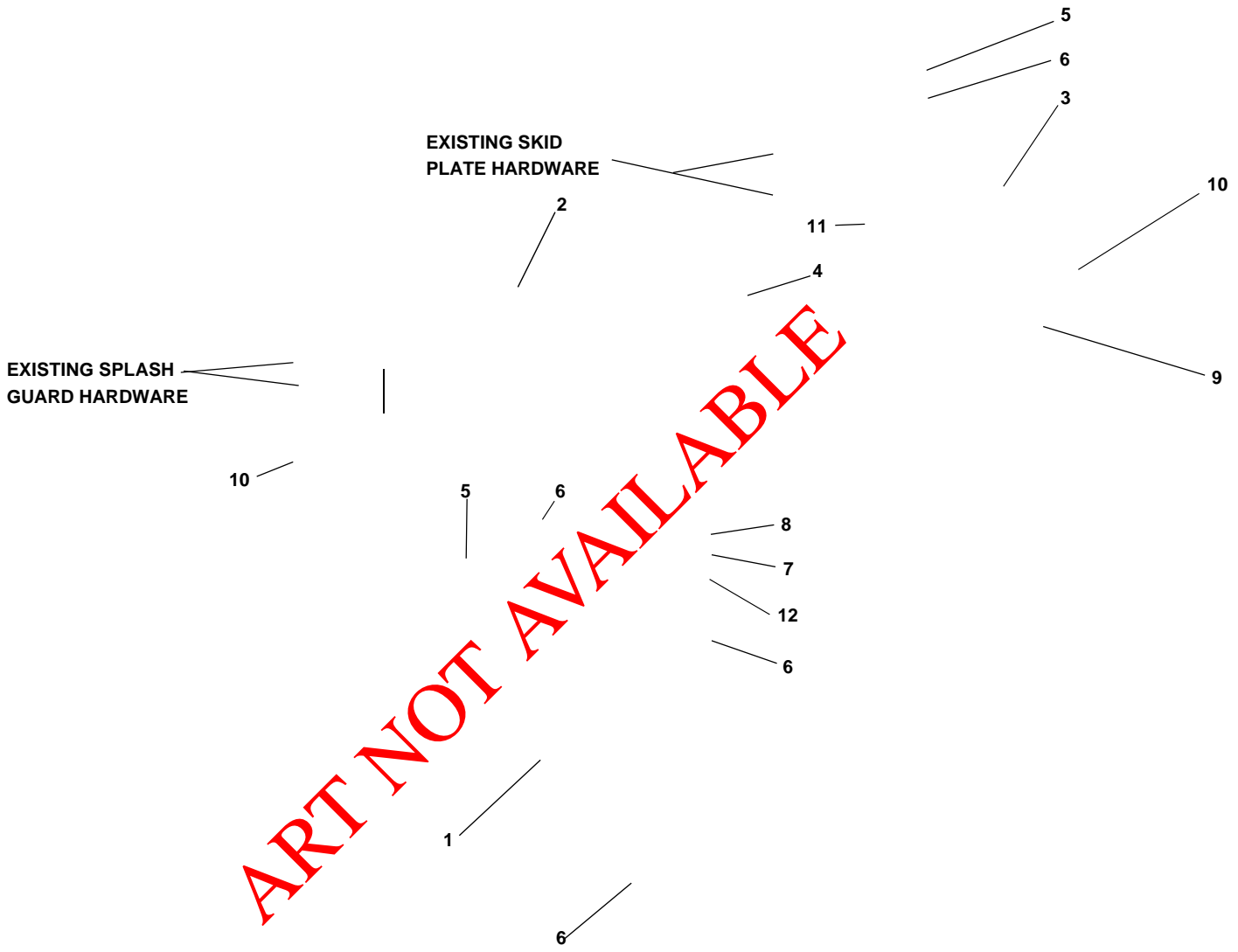

ITEM	PART NO.	DESCRIPTION	QTY.
1	96100694	Sub-Frame, Nose Piece (96100294)	1
2	96100460	Crossmember, Front	1
3	96100466	Crossmember, Rear.....	1
4	96100465	Plate, Reinforcement	2
5	98009039	Washer, Flat, 5/8"	5
6	98009038	Nut, Hex, Nylock, 5/8"-11NC	9
7	98009008	Washer, Lock, 3/8	4
8	98009032	Washer, Flat, 3/8"	4
9	98009217	Capscrew, Hex Head, 5/8"-11NC x 3"	2
10	98009115	Capscrew, Hex Head, 5/8"-11NC x 1-1/2"	6
11	98009111	Capscrew, Hex Head, 5/8"-11NC x 4-1/2"	1
12	98009034	Capscrew, Hex Head, 3/8"-16NC x 1-1/4"	4



SNO-WAY INTERNATIONAL, INC.