



Assembly & Installation Instructions

**FOR
SUBFRAME COMPONENTS PACKAGE 99100090
AND
SUBFRAME NOSE PIECE PACKAGE 96100731**

**TO FIT
1987 & LATER JEEP 4X4 WRANGLER**

97100207B



1. **THINK SAFETY, ALWAYS WEAR SAFETY GLASSES WHEN PERFORMING THE OPERATIONS PRESCRIBED IN THESE INSTRUCTIONS**
2. **READ ALL INSTRUCTIONS CAREFULLY BEFORE ATTEMPTING INSTALLATION**
3. **BEFORE BEGINNING WORK MAKE SURE TO SET PARKING BRAKE AND CHOCK WHEELS**

MINIMUM VEHICLE RECOMMENDATIONS

Heavy Duty Alternator
Heavy Duty Battery
Heavy Duty Suspension
Timbren Load Boosters

ASSEMBLY TOOLS NEEDED

Drill Bits 21/32"
Sockets 7/16" – 1-1/8"
Wrenches 7/16" – 1-1/8"
Torque Wrench

INSTALLATION NOTES

1. Unless specified, mount all Sub-frame components to vehicle before tightening any bolts.
2. Vehicle should be parked on a level surface with the front suspension normally loaded.

NOTE: Use Spacer (#96101407) and Back Up Plate (#96101442) between Bracket Assembly and vehicle frame. Use Back Up Plate (#96101440) and (#96101442) on inside of vehicle frame.

NOTE: The third bolt hole on the inside of the frame will need to be drilled to 21/32". Use Left Bracket Assembly as a template.

MOUNTING INSTRUCTIONS

1. Remove plastic guard located above and behind bumper.
2. Remove the two (2) self tapping screws used to retain the brake line mounting strip which was beneath the plastic guard.
3. Utilizing the existing holes in frame install Left and Right Bracket Assemblies (#96100837)LH, (#96100838)RH and secure each Bracket Assembly using seven (7) 5/8" x 4-1/2" Capscrews (#98009111), Flat Washer and Nylock Nuts provided.

4. Mount Front Crossmember (#96101578) to Sub-Frame Assembly with two (2) 5/8" x 1-1/2" Capscrews (#98009115), Flat Washers and Nylock Nuts provided.

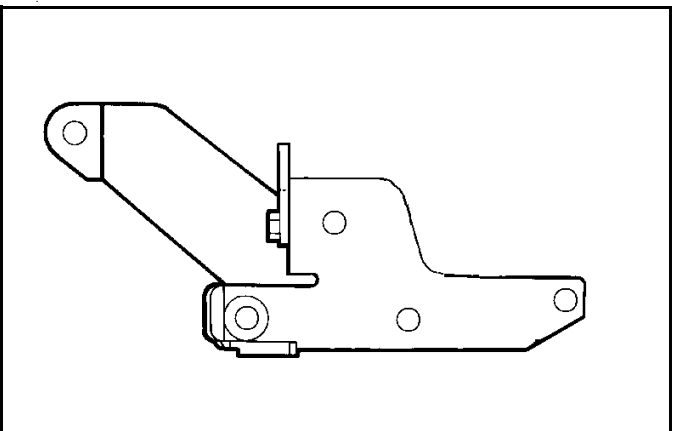

5. Mount Sub-Frame Assembly to Left and Right Bracket Assemblies using four (4) 5/8" x 2" Capscrews (#98009041) and two (2) 5/8" x 5-1/2" Capscrews (#98100068) Flat Washers and Nylock Nuts provided.

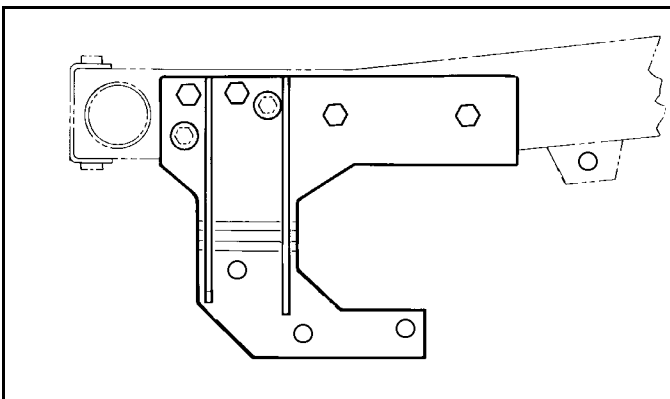

6. Secure upper end of Short Link to tab in vehicle frame with one (1) 5/8" x 2-1/2" Capscrews (#98009259). Secure with Nylock nut provided.
7. Install Short Link (#96001763) to Left Hand (Driver Side) Side Bracket Assembly lower bolt hole with one (1) 5/8"x 5-1/2" Capscrew (#98100068). Secure with Spacers (#96100548) and Nylock Nut provided.

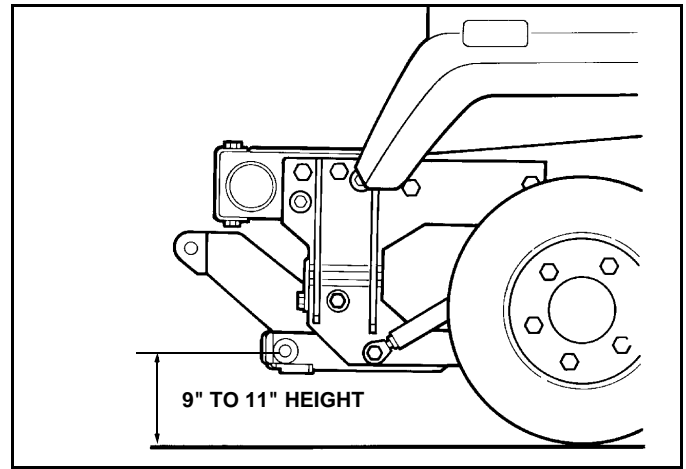
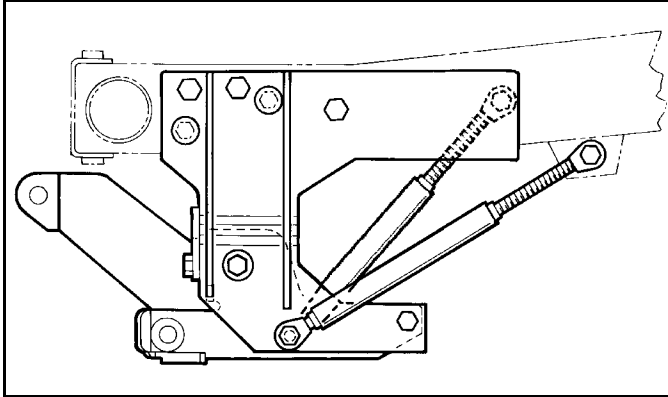

IMPORTANT: height from the center of the lower Plow Mounting holes on the Sub-Frame to the ground should be between 9" and 11" to insure proper operation.

REMEMBER After 5 to 10 hours of snowplow usage, re-torque all capscrews!

8. Install Long Link (#96001831) to Right Hand (Passenger Side) Side Bracket Assembly lower bolt hole with one (1) 5/8"x 5-1/2" Capscrew (#98100068). Secure with Nylock nut provided.
9. Secure upper end of Long Link to rear bolt hole in Side Bracket Assembly with one (1) 5/8"x 5-1/2" Capscrew (#98100068). Secure with Nylock nut provided.
10. Using the Torque Specification Chart below torque all capscrews starting at the rear and working forward.

TORQUE SPECIFICATIONS FOR STANDARD MACHINE HARDWARE

Bolt Size	GR.2 Dry	GR.5 Dry	GR.8 Dry	Metric Size	GR.8.8 Dry
1/4"	66*	9	12	M8	17
5/16"	11	17	25	M10	35
3/8"	20	30	45	M12	60
7/16"	32	50	70	M14	95
1/2"	50	75	110	M16	155
9/16"	70	110	150		
5/8"	100	150	220		
3/4"	175	260	380		
7/8"	170	430	600		
1"	250	640	900		

Note: These torque values are to be used for all hardware. Unless otherwise specified, all torque values must meet this specification.
 Note: All torque values are in Ft.-Lbs unless otherwise stated
 Note: *In-Lbs

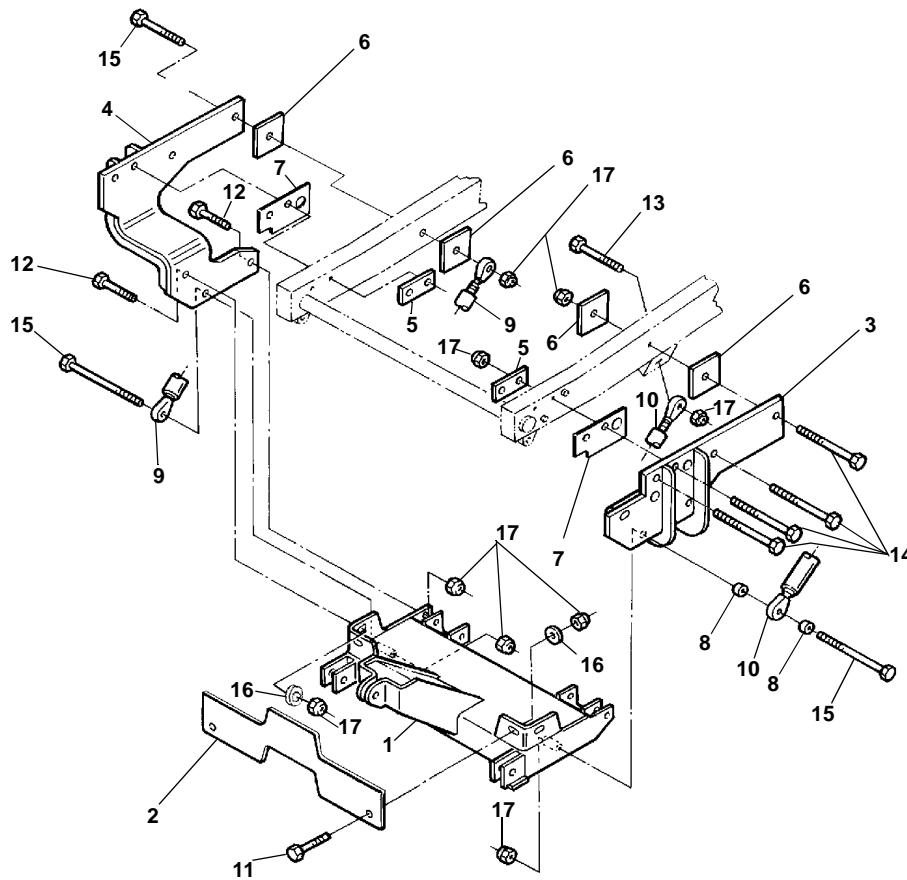

ITEM	PART NO.	DESCRIPTION	QTY.
1	96100731	Sub-Frame, Nose Piece (96100477).....	1
2	96101578	Crossmember, Front	1
3	96100837	Bracket, Left Assembly.....	1
4	96100838	Bracket, Right Assembly	1
5	96101440	Plate, Back Up	2
6	96101442	Plate, Back Up	4
7	96101407	Spacer.....	2
8	96100548	Spacer.....	2
9	96001831	Link, Adjustable (Long)	1
10	96001763	Link, Adjustable (Short).....	1
11	98009115	Capscrew, Hex Head, 5/8"-11NC x 1-1/2".....	2
12	98009041	Capscrew, Hex Head, 5/8"-11NC x 2".....	4
13	98009259	Capscrew, Hex Head, 5/8"-11NC x 2-1/2".....	1
14	98009111	Capscrew, Hex Head, 5/8"-11NC x 4-1/2".....	7
15	98100068	Capscrew, Hex Head, 5/8"-11NC x 5-1/2".....	3
16	98009039	Washer, Flat, 5/8".....	4
17	98009038	Nut, Hex, 5/8"-11NC Nylock.....	17



SNO-WAY INTERNATIONAL, INC.