



Assembly & Installation Instructions

**FOR
SUBFRAME COMPONENTS PACKAGE 99100113
AND
SUBFRAME NOSE PIECE PACKAGE 96103001**

TO FIT

1994 & LATER CHEVROLET S - SERIES PICKUP 4x4

1994 & LATER GMC S - SERIES PICKUP 4x4

1995 & LATER CHEVROLET S-SERIES BLAZER 4x4

1995 & LATER GMC S-SERIES JIMMY 4x4

EXCLUDES ZR2 CHASSIS PACKAGE

97100218D



1. THINK SAFETY, ALWAYS WEAR SAFETY GLASSES WHEN PERFORMING THE OPERATIONS PRESCRIBED IN THESE INSTRUCTIONS
2. READ ALL INSTRUCTIONS CAREFULLY BEFORE ATTEMPTING INSTALLATION
3. BEFORE BEGINNING WORK MAKE SURE TO SET PARKING BRAKE AND CHOCK WHEELS



MINIMUM VEHICLE RECOMMENDATIONS

Heavy Duty Alternator Heavy Duty Battery

NOTE: On some vehicles it may be necessary to use a form of load booster to decrease the vehicle's front suspension sag with the snow plow in place. This can be accomplished with the use of supplementary air bags, booster springs, or similar load boosting devices. Since there are different load boosting devices available, it will up to the customer/end user to decide and purchase the product to suit the application, and not the responsibility of Sno-Way International, Inc.

ASSEMBLY TOOLS NEEDED

Sockets	7/16" – 1-1/8"
Wrenches	7/16" – 1-1/8"
Metric Sockets	10mm – 19mm
Torque Wrench	
Hacksaw	

INSTALLATION NOTES

1. Unless otherwise specified, mount all Sub-Frame Components to vehicle before tightening any hardware.
2. It is recommended that LOCTITE®, or similar thread locking product, be used on ALL mounting hardware (i.e. Nuts, Cap Screws, Bolts, etc.).
3. Vehicle should be parked on a level surface with a normal vehicle load on the FRONT suspension.
4. Items in parentheses () refer to quantity required for this step. Items in parentheses with a pound sign (#) indicate the part number as found in the parts list on the last page of this document.
Example: (2) 5/8" x 11 x 1-1/2" Cap Screws (#9).
5. It maybe necessary to relocate license plate holder. Check state and local laws for placement, if needed.

NOTE: Air dam may be used with Plow by cutting dam to allow clearance for nose of Sub-Frame. To modify air dam measure 2-7/8" from each side of center and remove section from between the marked areas to clear nose of Sub-Frame.

2. Remove skid plate. Retain for future use if Plow Sub-Frame is removed.
3. Relocate licence plate if required.
4. Remove tow hooks and retain hardware for use in mounting Crossmember.

MOUNTING INSTRUCTIONS

1. Remove air dam. Retain, with mounting hardware, for future use if Plow Sub-Frame is removed.

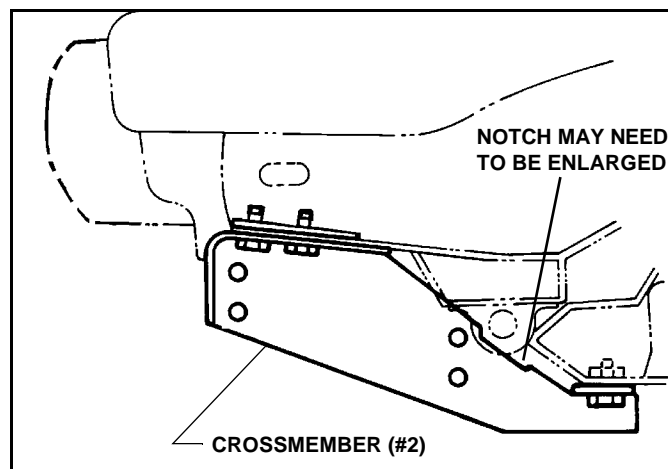
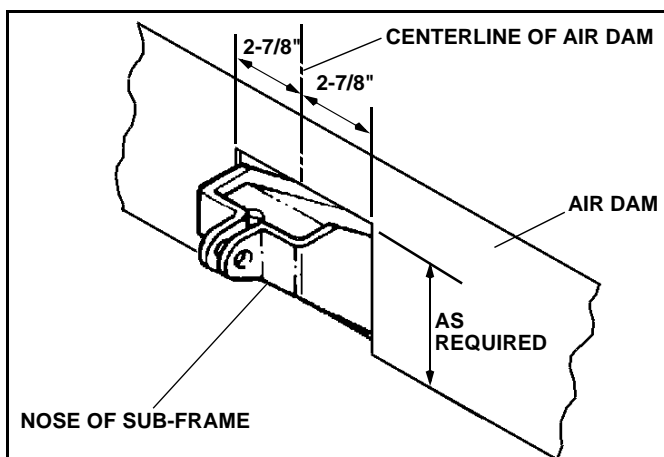

NOTE: On some vehicles the notch on the Crossmember (#2) may have to be enlarged due to manufacturer's tolerances.

5. Align Crossmember (#2) with holes formerly used for mounting skid plate and tow hooks. Secure using hardware formerly used to mount tow hooks and air dam. If vehicle **was not** equipped with tow hooks use (2) Reinforcing Plates (#3) and secure with (4) 3/8" x 1-1/4" Cap Screws (#12), Flat Washers (#8) and Lock Washers (#7).

NOTE: It is recommended that **LOCTITE®** or similar thread locking material be used when re-installing existing hardware.

6. Install (1) 5/8" x 4-1/2" Cap Screws (#11) in center hole in lower rear section of Crossmember and through existing hole in vehicle frame. Secure with, Flat Washer (#5) and Nylock Nut (#6).

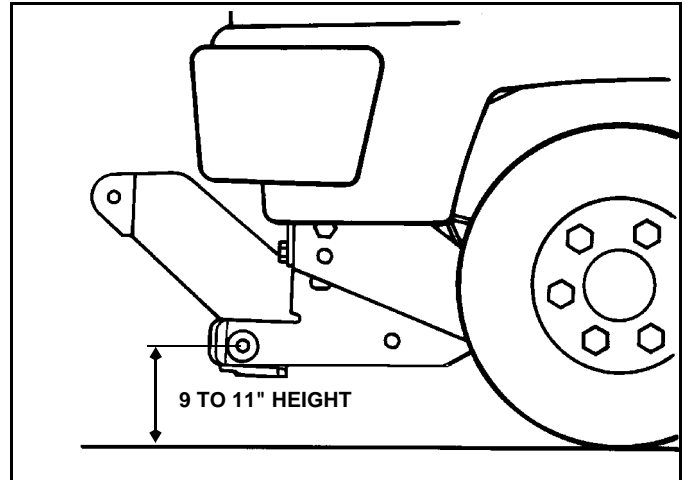
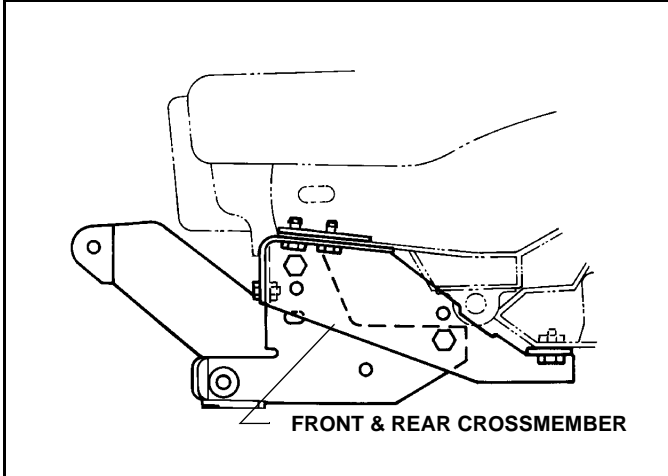

IMPORTANT: Height from the center of the lower Plow Mounting holes on the Sub-Frame to the ground should be between 9" and 11" to insure proper operation.

7. Raise front of Sub-Frame Assembly (#1) and align mounting holes in Crossmember (#2) front. Secure using (4) 5/8" x 1-1/2" Cap Screws (#9), Flat Washer (#5) and Nylock Nut (#6).

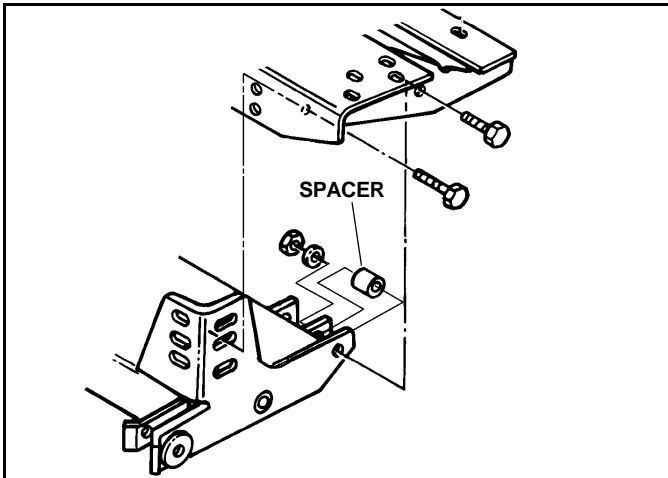

NOTE: Use two (2) Spacers (#4) between ears of Sub-Frame Assembly rear mounting point. (See illustration)

8. Secure rear of Sub-Frame Assembly to Crossmember (#2) rear with (2) 5/8" x 3" Cap Screws (#10), Flat Washer (#5) and Nylock Nut (#6).
9. Using the Torque Specification Chart, torque all Cap Screws starting at the rear and working forward.

**TORQUE SPECIFICATIONS FOR
STANDARD MACHINE HARDWARE**

Bolt Size	GR.2 Dry	GR.5 Dry	GR.8 Dry	Metric Size	GR.8.8 Dry
1/4"	66*	9	12	M8	17
5/16"	11	17	25	M10	35
3/8"	20	30	45	M12	60
7/16"	32	50	70	M14	95
1/2"	50	75	110	M16	155
9/16"	70	110	150		
5/8"	100	150	220		
3/4"	175	260	380		
7/8"	170	430	600		
1"	250	640	900		

These torque values are to be used for all hardware. Unless otherwise specified, all torque values must meet this specification.

All torque values are in Ft.-Lbs unless otherwise stated

*In-Lbs

REMEMBER After 5 to 10 hours of snowplow usage, re-torque all Cap Screws!

NOTE: In order to change engine oil filter it will be necessary to remove the Sub-Frame Assembly (#1) only.

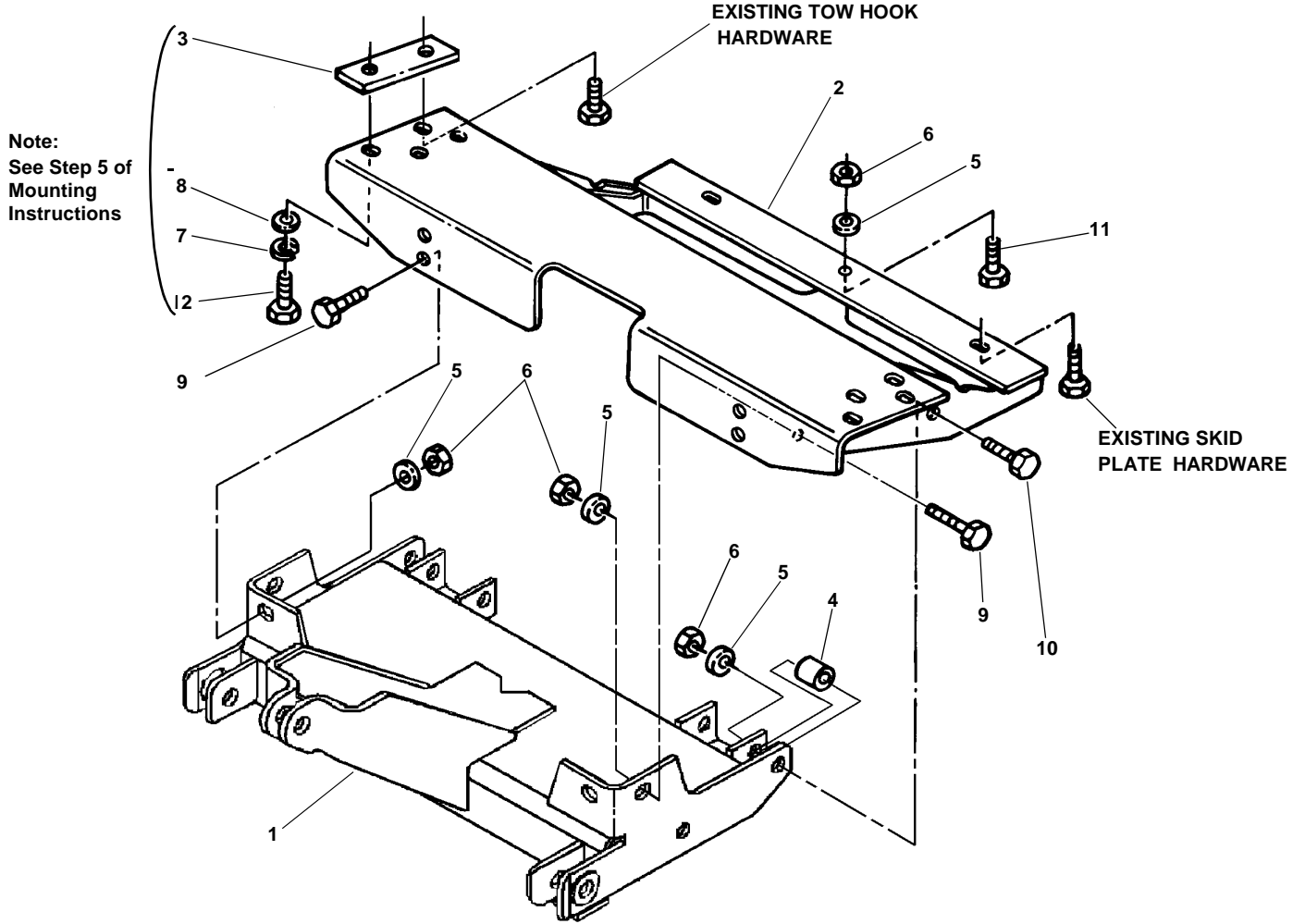

ITEM	PART NO.	DESCRIPTION	QTY.
1	96103001	Sub-Frame, Nose Piece (96102924)	1
2	96100710	Crossmember, Front / Rear	1
3	96100465	Plate, Reinforcement	2
4	96001656	Spacer.....	2
5	98009039	Washer, Flat 5/8".....	7
6	98009038	Nut, Hex, Nylock, 5/8" -11	7
7	98009008	Washer, Locking, 3/8"	4
8	98009032	Washer, Flat 3/8"	4
9	98009115	Cap Screw, Hex Head, 5/8" -11 x 1-1/2"	4
10	98009217	Cap Screw, Hex Head, 5/8" -11 x 3"	2
11	98009111	Cap Screw, Hex Head, 5/8" -11 x 4-1/2"	1
12	98009034	Cap Screw, Hex Head, 3/8" -16 x 1-1/4"	4

SNO-WAY® INTERNATIONAL, INC.



©1999 Sno-Way® International