



# **Assembly & Installation Instructions**

**FOR  
SUBFRAME COMPONENTS PACKAGE 99100177  
AND  
SUBFRAME NOSE PIECE PACKAGE 96100731**

**TO FIT  
1991 – 94 ISUZU RODEO  
1988 – 94 ISUZU AMIGO  
1988 – 94 ISUZU 4X4 PICKUP**

97100263B



1. THINK SAFETY, ALWAYS WEAR SAFETY GLASSES WHEN PERFORMING THE OPERATIONS PRESCRIBED IN THESE INSTRUCTIONS
2. READ ALL INSTRUCTIONS CAREFULLY BEFORE ATTEMPTING INSTALLATION
3. BEFORE BEGINNING WORK MAKE SURE TO SET PARKING BRAKE AND CHOCK WHEELS

### MINIMUM VEHICLE RECOMMENDATIONS

Heavy Duty Alternator  
 Heavy Duty Battery  
 Heavy Duty Suspension

### ASSEMBLY TOOLS NEEDED

Drill Bits	1/4", 5/16", 13/32"
Sockets	7/16" – 1-1/8"
	14 mm – 17 mm
Wrenches	7/16" – 1-1/8"
	14 mm – 17 mm
Torque Wrench	
Tap	3/8" - 16 NC

### INSTALLATION NOTES

1. Unless specified, mount all Sub-frame components to vehicle before tightening any bolts.
2. Vehicle should be parked on a level surface with the front suspension normally loaded.

### MOUNTING INSTRUCTIONS

1. Remove vehicle skid plate (two pieces) and tow hook. Retain with hardware for future use if plow is removed.
2. Install Sub-Frame Assembly (#96100477) to Front Crossmember (#96101589) using four (4) 5/8" x 1-1/2" Capscrews (#98009115), Flat Washers and Nylock Nuts provided. Torque to specifications from Torque Chart below.

3. Mount Sub-Frame Assembly, from Step 2, to vehicle frame by aligning mounting holes in Front Crossmember with existing tapped holes in passenger side of vehicle frame, formerly used to secure tow hook. Using 5/8" Flat Washers (#98009039) as spacers between Crossmember and vehicle frame secure Crossmember using two (2) M10 - 1.25 x 40 Capscrews (#98100046) Lockwashers (#98009008) and Flat Washers provided.

*NOTE: When spacing Front Crossmember remember to keep subframe parallel to ground.*

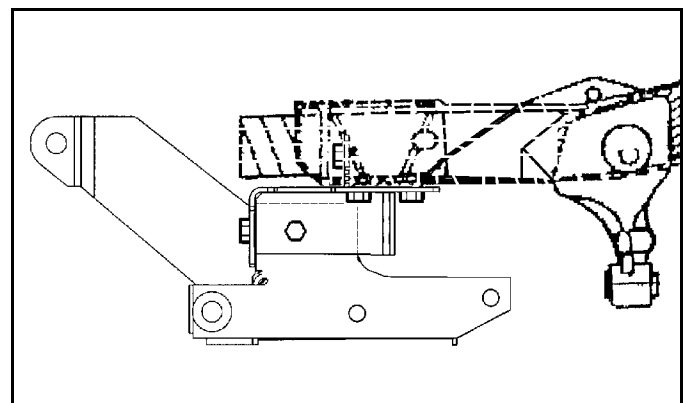
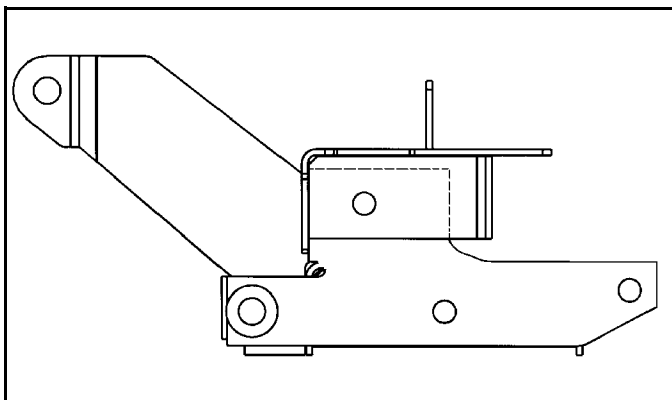

4. Inspect vehicle front crossmember to see if any holes line up with Crossmember upper face. If they do secure Crossmember to holes with two (2) 3/8" X 4" Capscrews (#98100087), Flat Washers and Nylock Nuts provided. If holes do not exist in vehicle crossmember continue with next step.
5. Remove existing vehicle hardware located directly in front of steering control box, left side, and control arm, right side. Retain with hardware for future use if

**IMPORTANT: Do not torque Capscrews until instructed to do so.**

plow is removed. Locate Left and Right Mounting Brackets (#96101590) LH, (#96101591) RH, over holes left by mounting hardware and secure Mounting Brackets using two (4) 3/8" X 4" Capscrews (#98100087), Flat Washers and Nylock Nuts provided.

- Loosely secure Left and Right Support Brackets (#96101597) LH, (#96101598) RH, to Left and Right Mounting Brackets using four (4) 1/2" x 1-1/2" Capscrews, Flat Washers and Nylock Nuts provided. Secure to Sub-Frame using two (2) 5/8" x 3" Capscrew (#98009217) in forward holes and (2) 5/8" x 1-1/2" Capscrew (#98009115) in rear holes. Secure with Nylock Nuts provided.

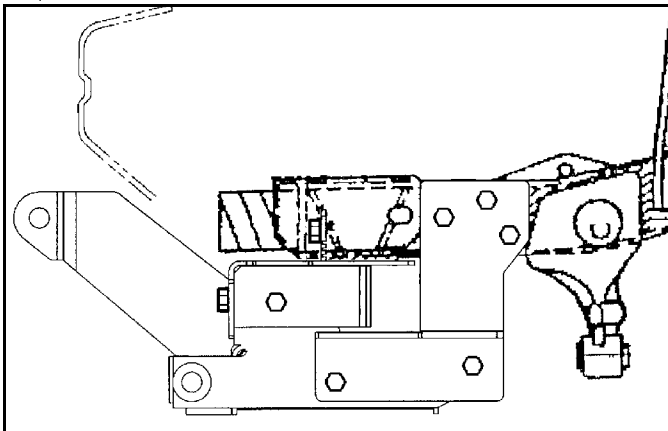

- Using appropriate Torque rate from Torque Specifications Chart below torque Capscrews in the following order:

- Rear Mounting Brackets To Vehicle Frame.
- Support Brackets To Rear Mounting Brackets
- Support Bracket to Sub-Frame.

- Using two (2) side mounting holes in Crossmember (drivers side) as a template drill vehicle frame with 5/16" Drill and tap with 3/8" 16 NC Tap. Secure using two (2) 3/8" X 1-1/2" Capscrews (#98009256), Lock Washers and Flat Washers provided.

**TORQUE SPECIFICATIONS FOR STANDARD MACHINE HARDWARE**

Bolt Size	GR.2 Dry	GR.5 Dry	GR.8 Dry	Metric Size	GR.8.8 Dry
1/4"	66*	9	12	M8	17
5/16"	11	17	25	M10	35
3/8"	20	30	45	M12	60
7/16"	32	50	70	M14	95
1/2"	50	75	110	M16	155
9/16"	70	110	150		
5/8"	100	150	220		
3/4"	175	260	380		
7/8"	170	430	600		
1"	250	640	900		

Note: These torque values are to be used for all hardware. Unless otherwise specified, all torque values must meet this specification.  
 Note: All torque values are in Ft.-Lbs unless otherwise stated  
 Note: \*In-Lbs

**NOTE:** Use 5/8" Flat Washers (#98009039) as spacers as required between vehicle frame and Crossmember.

- If holes in vehicle frame did not exist for securing Front Crossmember to vehicle frame (Step #3) drill 1/4" then 13/32" holes in front and rear walls of vehicle crossmember using Front Crossmember as a template. Insert two (2) 3/8" X 1-1/2" Capscrews (#98009256), and secure with Flat Washers and Nylock Nuts provided.

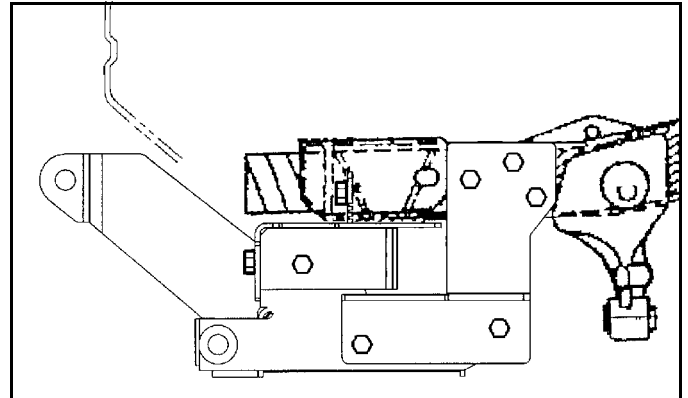

- Using remaining holes in Rear Mounting Brackets as a template drill 1/4" then 13/32" holes in front and rear walls of vehicle crossmember using Front Crossmember as a template. Insert two (2) 3/8" x 1-1/2" Capscrews (#98009256), and secure with Flat Washers and Nylock Nuts provided.

- Using the Torque Specification Chart below torque Capscrews installed in Steps 9,10,11 to specs.

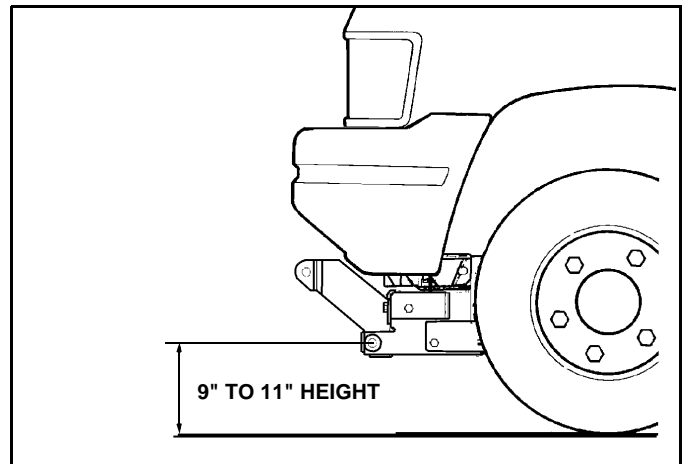

**IMPORTANT:** height from the center of the lower Plow Mounting holes on the Sub-Frame to the ground should be between 9" and 11" to insure proper operation.

**REMEMBER** After 5 to 10 hours of snowplow usage, re-torque all capscrews!

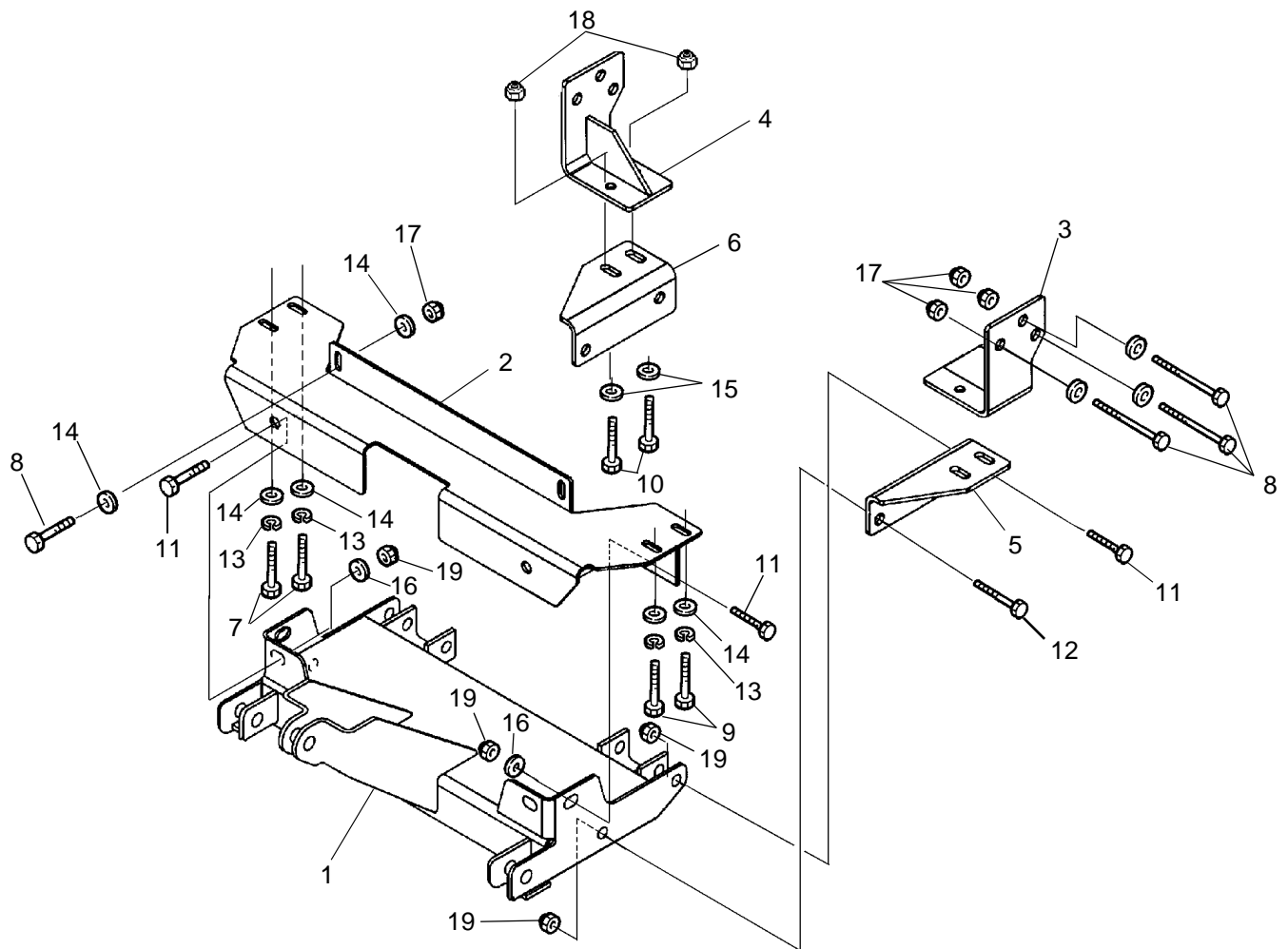

ITEM	PART NO.	DESCRIPTION	QTY.
1	96100731	Sub-Frame, Nose Piece (96100477).....	1
2	96101589	Crossmember, Front .....	1
3	96101590	Bracket, Mounting, Left Hand.....	1
4	96101591	Bracket, Mounting, Right Hand .....	1
5	96101597	Bracket, Support, Left Hand.....	2
6	96101598	Bracket, Support, Right Hand .....	4
7	98100046	Capscrew, Hex Head, M10 - 1.25 x 40 .....	2
8	98100087	Capscrew, Hex Head, 3/8"-16 NC x 4" .....	8
9	98009256	Capscrew, Hex Head, 3/8"-16 NC x 1-1/2" .....	2
10	98009010	Capscrew, Hex Head, 1/2"-13 NC x 1-1/2" .....	4
11	98009115	Capscrew, Hex Head, 5/8"-11 NC x 1-1/2" .....	6
12	98009217	Capscrew, Hex Head, 5/8"-11 NC x 3" .....	2
13	98009008	Washer, Lock, 3/8" .....	4
14	98009032	Washer, Flat, 3/8" .....	14
15	98009011	Washer, Flat, 1/2" .....	4
16	98009039	Washer, Flat, 5/8" .....	14
17	98009009	Nut, Hex, 3/8"-16 NC Nylock.....	8
18	98009013	Nut, Hex, 1/2"-13 NC Nylock.....	4
19	98009038	Nut, Hex, 5/8"-11 NC Nylock.....	8



SNO-WAY INTERNATIONAL, INC.