



# **Assembly & Installation Instructions**

**FOR  
SUBFRAME COMPONENTS PACKAGE 99100185  
AND  
SUBFRAME NOSE PIECE PACKAGE 96103002**

**TO FIT**

**1980 - 1991 FORD 4X2 F250HD & F350 (8600GVWR)**

**1985 - 1991 FORD 4X2 F350 CHASSIS CAB**

**1988 - 1991 FORD 4X2 F-SUPER DUTY CHASSIS CAB**

97100399B



1. THINK SAFETY, ALWAYS WEAR SAFETY GLASSES WHEN PERFORMING THE OPERATIONS PRESCRIBED IN THESE INSTRUCTIONS
2. READ ALL INSTRUCTIONS CAREFULLY BEFORE ATTEMPTING INSTALLATION
3. BEFORE BEGINNING WORK MAKE SURE TO SET PARKING BRAKE AND CHOCK WHEELS

## MINIMUM VEHICLE RECOMMENDATIONS

Heavy Duty Alternator  
Heavy Duty Battery  
Heavy Duty Front Springs  
Manufacturers Snow Plow Package  
(Where Applicable)

## ASSEMBLY TOOLS NEEDED

Drill Bits 1/4", 17/32"  
Impact Sockets 7/16" – 1-3/8"  
Wrenches 7/16" – 1-3/8"  
Torque Wrench  
Center Punch and Hammer  
Clamping Device ("C", Bar, type device...)  
Rat Tail Pry Bar  
Hacksaw

## INSTALLATION NOTES

1. Unless otherwise specified, mount all Sub-Frame Components to vehicle before tightening any hardware.
2. It is recommended that LOCTITE®, or similar thread locking product, be used on ALL mounting hardware (i.e. Nuts, Cap Screws, Bolts, etc.).
3. Vehicle should be parked on a level surface with a normal vehicle load on the FRONT suspension.
4. Items in parentheses () refer to quantity required for this step. Items in parentheses with a pound sign (#) indicate the part number as found in the parts list on the last page of this document. Example: (2) 5/8" x 1-1/2" Cap Screws (#17)
5. It maybe necessary to relocate license plate holder. Check state and local laws for placement, if needed.

## MOUNTING INSTRUCTIONS

### • Vehicles from 1980 - 1986

1. Remove front bumper from vehicle.

*NOTE: It may be necessary to use Shim Plate (#8) between the Front Crossmember (#2) and the vehicle frame rails.*

2. Mount (1) Front Crossmember (#2) over vehicle frame horns. Leaving approximately a 1/4" gap between the top of the frame and the inside top of the Front Crossmember, keeping the front face of the Front Crossmember perpendicular to the ground, clamp in place. Using the holes in the Front Crossmember as a template, center punch and drill (4) holes, through the vehicle frame rail, by first using a 1/4" and then a 17/32" drill bits. Secure tightly in place using (4) 1/2 x 1-1/2" Cap Screws (#13), and on the engine side of the frame, (4) 1/2" Flat Washers (#14) and (4) 1/2" Nylock Nuts (#16). (See Install Notes #1 & #2.)
3. Reinstall front bumper by first placing (4) Spacer Tubes (#9) over the (4) 1/2 x 2-1/4" Carriage Bolts (#12), and inserting through holes from the outside of the Front Cross-Member (#2), on the engine side of the frame, secure in place using (4) 1/2" Flat Washers (#14), (4) 1/2" Lock Washers (#15) and (4) 1/2" Nylock Nuts (#16). (See Install Notes #1 & #2.)

### • Vehicles from 1987 - 1991

1. Remove the vehicle front bumper assembly, by removing the four (4) nuts that secure the bumper to the bumper support, retain hardware for later use.
2. Remove air dam from bumper, with hardware and retain for future use if Sub-Frame is removed.

*NOTE: Front air dam can be modified to clear Sub-Frame by cutting dam to allow clearance for nose of Sub-Frame. Cut air dam as shown and remove cut section or fold back for when nose piece is removed.*

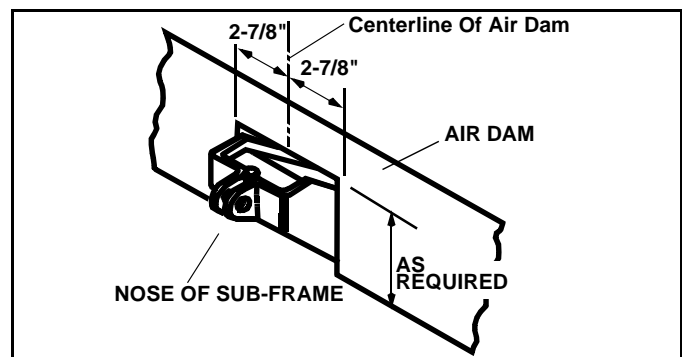

*NOTE: It may be necessary to use Spacer Plate (#8) between the Front Crossmember (#2) and the vehicle frame rails.*

3. Mount (1) Front Crossmember (#2) over vehicle frame horns, getting the mounting holes as close to existing holes in the vehicle frame.
4. Raise front bumper and mounting bracket and align front bumper and mounting bracket holes with the mounting holes of the Front Crossmember. Keeping the front face of the Front Crossmember perpendicular to the ground, secure using (4) 1/2 x 2" Cap Screws (#13), (4) 1/2" Flat Washers (#14) and (4) 1/2" Nylock Nuts (#16). (See Install Notes #1 & #2.)

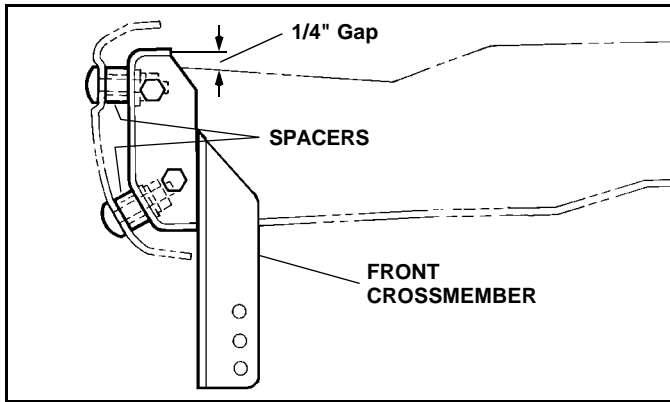

5. Place (1) Rear Crossmember (#3) over (1) Sub-Frame Nose Piece (#1) and secure as follows:

- Rear Mounting - (2) 5/8" x 1-1/2" Cap Screws (#17), (2) Lock Washer (#19), and (2) 5/8" Nylock Nuts (#22). (See Install Notes #1 & #2.)
- Front Mounting - (2) 5/8" x 3-1/2" Cap Screws (#23), (2) Lock Washer (#19), and (2) 5/8" Nylock Nuts (#22). (See Install Notes #1 & #2.)

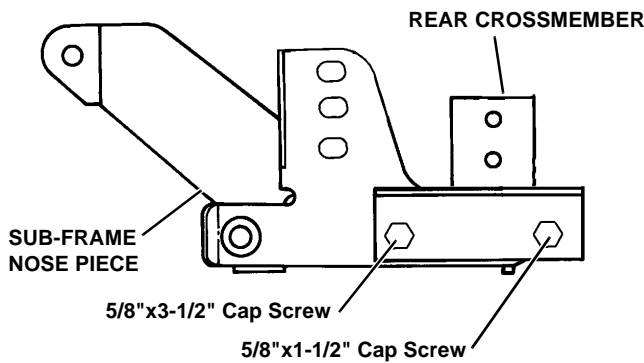

**IMPORTANT:** The Cap Screws securing the Sub-Frame to the Front Crossmember must be staggered with the front bolts being positioned in a lower set of holes than the side bolts. (Unless the holes are in the lowest possible position)

6. Attach Sub-Frame assembly to Front Crossmember (#2) using (4) 5/8" x 1-1/2" Cap Screws (#23), (4) 5/8" Flat Washers (#21), and (4) 5/8" Nylock Nuts (#22), provided. (See Install Notes #1, & #2.)

**IMPORTANT:** Height from the center of the lower Plow Mounting holes on the Sub-Frame into the ground should be between 9" and 11" to insure proper operation.

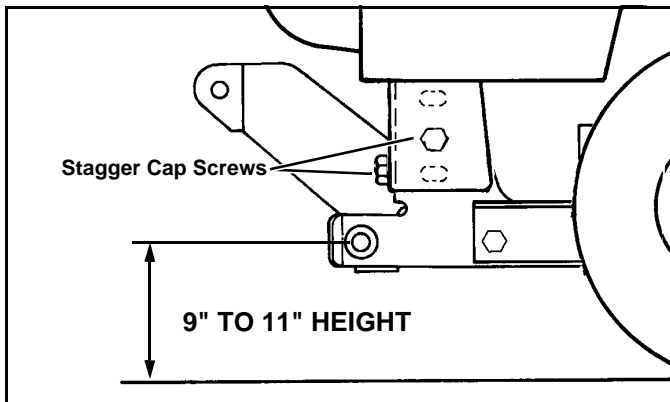

**NOTE:** It may be necessary to use Shim Plates (#10), & (#11) between the Rear Crossmember and the Rear Mounting Brackets.

7. From the engine side of the Rear Crossmember place (4) 5/8" x 3-1/2" Cap Screws (#20), with (4) 5/8" Lock Washer (#19), into holes for the Rear Mounting Brackets (#4) LH, and (#5) RH. Secure with (4) 5/8" Nylock Nuts (#22). Clamp both Rear Mounting Brackets to the vehicle frame making sure the brackets are tight with the bottom and sides of the vehicle frame and the Sub-Frame is parallel to the ground. (See Install Notes #1 & #2.)



## WARNING

**Beware of brake and fuel lines secured to inside wall of frame rails when drilling holes in vehicle frame! FAILURE TO HEED CAN RESULT IN SERIOUS INJURY OR DEATH.**

8. Using the (8) holes in the Rear Mounting Brackets (#4) LH, & (#5) RH as a template center punch and drill (8) holes through the vehicle frame rail, first using a 1/4", then a 17/32" drill bit. Remove clamps and secure Brackets using (8) 1/2" x 1-1/2" Cap Screws (#13) with (8) 1/2" Lock Washer (#15) and on the engine side of the frame rails using (1set) Nut Plate Assembly (#6) LH, and (#7) RH placed so wire handles face to the front of the vehicle. (See Install Notes #1 & #2.)

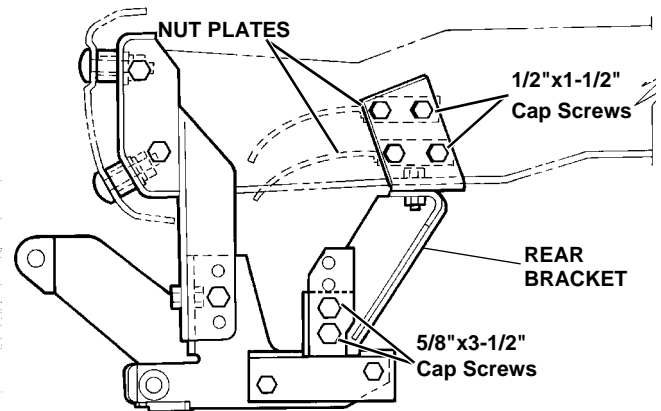

9. Using the Torque Specification Chart below, torque all bolts starting at the rear and working forward.

TORQUE SPECIFICATIONS FOR STANDARD MACHINE HARDWARE					
Bolt Size	GR.2 Dry	GR.5 Dry	GR.8 Dry	Metric Size	GR.8.8 Dry
1/4"	66*	9	12	M8	17
5/16"	11	17	25	M10	35
3/8"	20	30	45	M12	60
7/16"	32	50	70	M14	95
1/2"	50	75	110	M16	155
9/16"	70	110	150		
5/8"	100	150	220		
3/4"	175	260	380		
7/8"	170	430	600		
1"	250	640	900		

Note: These torque values are to be used for all hardware. Unless otherwise specified, all torque values must meet this specification.  
Note: All torque values are in Ft.-Lbs unless otherwise stated  
Note: \*In-Lbs

**REMEMBER** After 5 to 10 hours of snowplow usage, re-torque all Cap Screws!

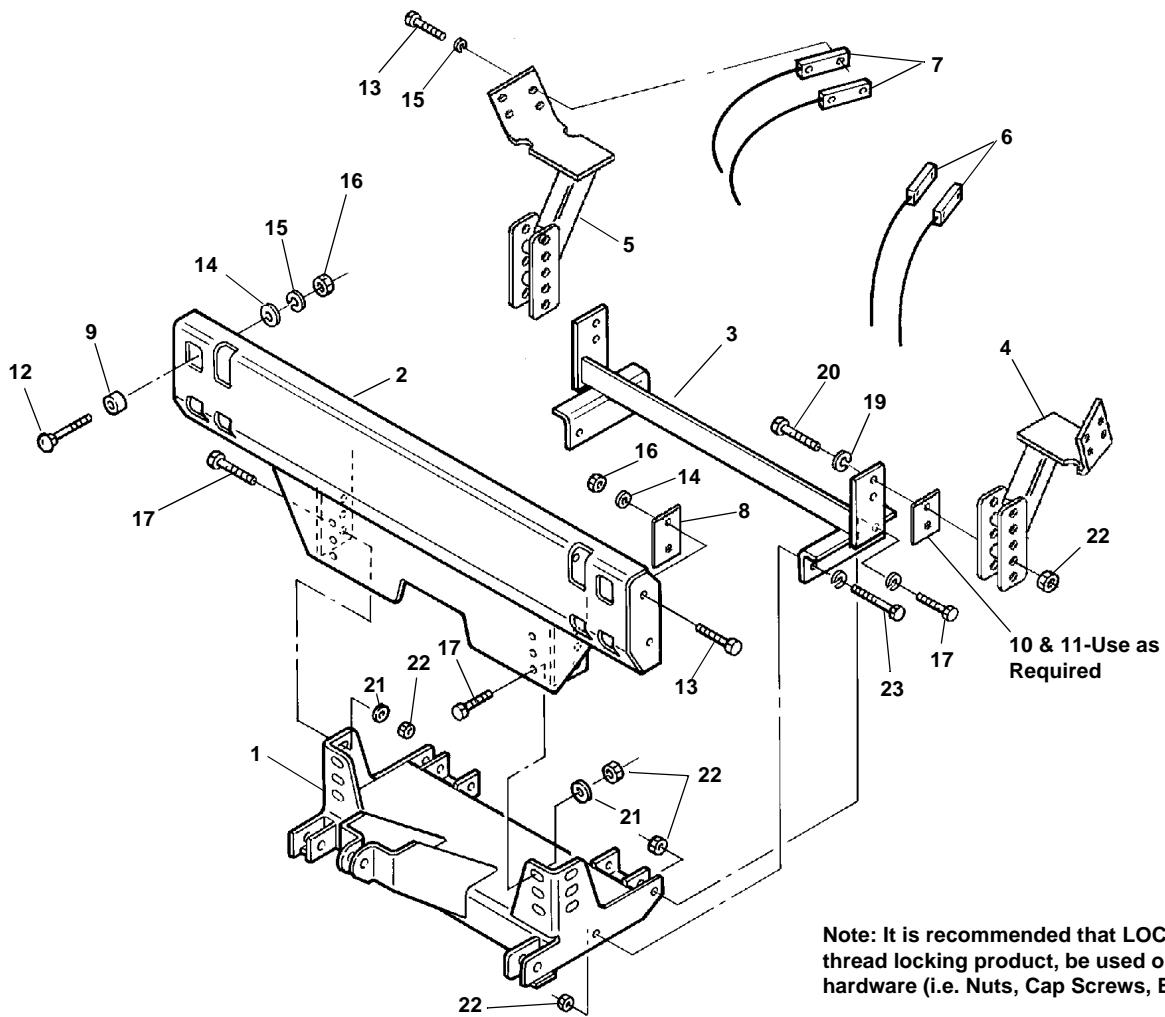

ITEM	PART NO.	DESCRIPTION	QTY.
1	96103002	Sub-Frame, Nose Piece (96102896) .....	1
2	96102212	Crossmember, Front .....	1
3	96101387	Crossmember, Rear .....	1
4	96103070	Bracket, Rear Mounting, LH .....	1
5	96103071	Bracket, Rear Mounting, RH .....	1
6	98000939	Plate, Nut, Left .....	2
7	96100938	Plate, Nut, Right .....	2
8	96101400	Plate, Spacer .....	4
9	96101465	Tube, Spacer .....	4
10	96102214	Plate, Shim, 1/8" .....	2
11	96103075	Plate, Shim, 1/4" .....	2
12	98100067	Bolt, Carriage, 1/2-13 x 2-1/4 Gr. 5 .....	4
13	98009010	Cap Screw, Hex Head, 1/2-13 UNC x 1-1/2" .....	12
14	98009011	Washer, Flat, 1/2" .....	8
15	98009012	Washer, Lock, 1/2" .....	8
16	98009013	Nut, Hex, Nylock, 1/2-13 UNC .....	8
17	98009115	Cap Screw, Hex Head, 5/8-11 UNC x 1-1/2" .....	6
18	98009196	Cap Screw, Hex Head, 5/8-11 UNC x 5" .....	2
19	98009062	Washer, Lock, 5/8" .....	8
20	98009042	Cap Screw, Hex Head, 5/8-11 UNC x 3-1/2" .....	4
21	98009039	Washer, Flat, 5/8" .....	4
22	98009038	Nut, Hex, Nylock, 5/8-11 UNC .....	12
23	98009217	Cap Screw, Hex Head, 5/8-11 UNC x 3" .....	2



SNO-WAY INTERNATIONAL, INC.