



**Assembly  
&  
Installation Instructions**

**FOR  
SUBFRAME COMPONENTS PACKAGE 99100190  
AND  
SUBFRAME NOSE PIECE PACKAGE 96100694**

**TO FIT**

**1994 & LATER DODGE 4X2 RAM, BR2500HD, BR3500  
(SINGLE & DUAL REAR WHEELS)**

**1994 & LATER DODGE 4X2 RAM, BR3500 CHASSIS CAB  
(SINGLE & DUAL REAR WHEELS)**

97100427B



1. **THINK SAFETY, ALWAYS WEAR SAFETY GLASSES WHEN PERFORMING THE OPERATIONS PRESCRIBED IN THESE INSTRUCTIONS**
2. **READ ALL INSTRUCTIONS CAREFULLY BEFORE ATTEMPTING INSTALLATION**
3. **BEFORE BEGINNING WORK MAKE SURE TO SET PARKING BRAKE AND CHOCK WHEELS**

## MINIMUM VEHICLE RECOMMENDATIONS

Heavy Duty Alternator  
Heavy Duty Battery  
Air-Adjustable Suspension Kit (Where Necessary)

## ASSEMBLY TOOLS NEEDED

Drill Bits	21/32"
Impact Sockets	7/16" – 1-3/8"
Wrenches	7/16" – 1-3/8"
Torque Wrench	
Hammer and Center Punch	
Hacksaw	

## INSTALLATION NOTES

1. Unless specified, mount all Sub-Frame Components to vehicle before tightening any bolts.
2. Vehicle should be parked on a level surface with the front suspension normally loaded.

## MOUNTING INSTRUCTIONS

1. If vehicle is equipped with lower valance panel the corners must be removed. Measure 1/2" ahead of rear face of vehicle front cross member, and scribe a line across panel to a point 2-3/4" inside of inner side of frame rail. Cut off previously marked corners of lower valance panel.
2. Remove bolts and stud plate fastening bumper support brackets to front of frame.
3. Locate Subframe Mounting Bracket (#96001657) on frame of vehicle.

*NOTE: If Subframe Mounting Bracket is less than 1/8" wider than the frame no shims are needed. If gap is more than 1/8" but less than 1/4" install one (1) each Shim (#96001644) and (#96001645) between vehicle frame and one (1) side of Subframe Mounting Bracket. If gap is over 1/4" install two (2) each Shim (#96001644) and (#96001645) between frame and sides of Subframe Mounting Bracket.*

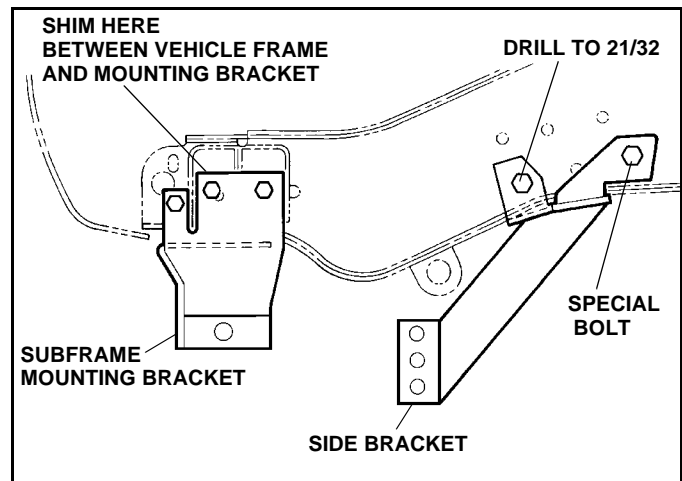

4. Attach Subframe Mounting Bracket and bumper support brackets, previously removed, with two (2) 1/2" x 1-1/2" Capscrews (#98009216), four (4) Flat Washers, and two (2) Nylock Nuts provided. Use previously removed bumper brackets bolts in the remaining holes in each bumper support bracket.
5. Install Subframe Corner Supports (#960001655)LH, and (#96001661)RH, to vehicle frame behind frame front cross member and above Subframe Mounting Bracket. Use one (1) 1/2" x 4" Capscrew, (#98009195) per corner with two (2) Washers and one (1) Nylock Nut per Capscrew.
6. Attach Corner Supports to vehicle front frame crossmember with two (2) 3/8" x 1-1/4" Capscrew (#98009034) four (4) Flat Washers and two (2) Nylock Nuts per Corner Support. Install one (1) 1/2" x 4" Capscrew (#98009195) with two (2) Flat Washers and one (1) Nylock Nut through each Corner Support, vehicle frame and Subframe Mounting Bracket. Fasten Corner Supports to Subframe Mounting Bracket with two (2) 3/8" x 1-1/4" Capscrews, (#98009034) double Flat Washers and Nylock Nuts provided.

7. Fasten RH Side Bracket (#96001633), to vehicle frame with Special Bolt (#96100623). Insert hook end of Special Bolt in 1" hole in outside of vehicle frame rail. Use Retainer (#96001642) to hold Special Bolt in place when Side Bracket is installed to prevent Special Bolt from falling into frame during Side Bracket installation. Use one (1) 3/4" Lock Washer, and one (1) Plain Nut to secure Special Bolt to Side Bracket, place a Spacer (#96102702) between rear hole of the Side Bracket and the vehicle frame. Secure Side Bracket to vehicle frame rail with one 5/8" x 4-1/2" Capscrew (#98009111), Flat Washer and Nylock Nut Provided.
8. Hold LH Side Bracket (#96001638) in place, aligning rear hole with 1" hole in vehicle frame rail.
  - On some vehicles the front hole will align with power steering pump mounting bolt. If so, remove the bolt and save for later use. Install the Special Bolt and related hardware as completed in Step #7 (above). Place a Spacer (#96102702) between rear hole of the Side Bracket and the vehicle frame and use power steering pump bolt to secure the side bracket. Torque to 180 ft-lb.
  - On some vehicles the front hole in side bracket aligns with an existing hole in the frame rail. If this occurs, use the hole in the bracket as a template to drill out the hole to 21/32". Place a Spacer (#96102702) between rear hole of the Side Bracket and the vehicle frame and secure Side Bracket to vehicle frame rail with one 5/8" x 4-1/2" Capscrew (#98009111), Flat Washer and Nylock Nut Provided.
9. Mount Sub-Frame (#96100294) to Subframe Mounting Bracket with four (4) 5/8" x 1-1/2" Capscrew (#98009115) double Flat Washers and Nylock Nuts provided.
10. Fasten Rear Crossmember (#96100650) to Sub-Frame with two (2) 5/8" x 3-1/2" Capscrews (#98009042) through tube welded into the lower center portion of the Sub-Frame and the front slotted hole in the Rear Crossmember, Use one (1) Flat Washer on Capscrew and Nylock Nuts provided. Install two (2) 5/8" x 3" Capscrews (#98009217) through holes in ears at lower rear of Subframe Mounting Brackets and through rear slotted holes in Crossmember. Use one (1) Spacer (#96001656) between the ears of the Subframe Mounting Brackets. Secure with Flat Washer and Nylock Nut provided.
11. Secure Rear Crossmember to Side Brackets with two (2) 5/8" x 1-1/2" Capscrews (#98009115) Flat Washer and Nylock Nut provided per Side Bracket.
12. After all components have been installed tighten hardware in the following order to specifications found in the Torque Specification Chart In this instruction sheet.
  - A. Tighten Capscrews fastening Subframe Mounting Brackets and Corner Supports to vehicle frame.
  - B. Tighten Special Bolt Nut to insure that the Special Bolt is properly seated in the frame.
  - C. Tighten Capscrews on Support Brackets.
  - D. Tighten 5/8" x 4-1/2" Capscrews in each Side Bracket.
  - E. Tighten Capscrews fastening the Sub-Frame to Subframe Mounting Brackets, Bracket to Sub-Frame Capscrews, and all remaining Capscrews

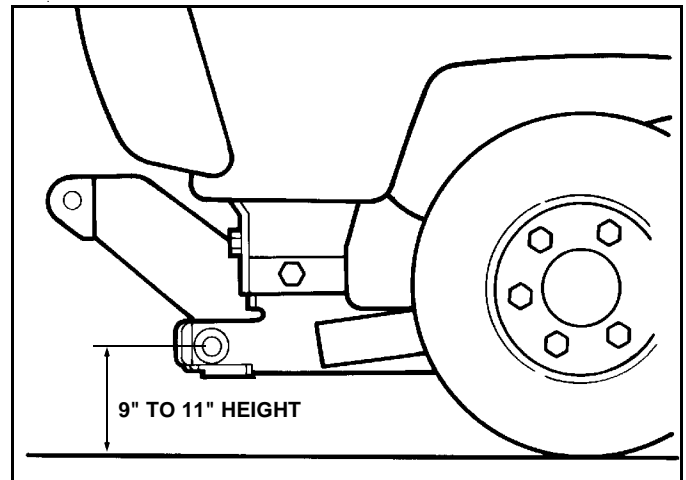
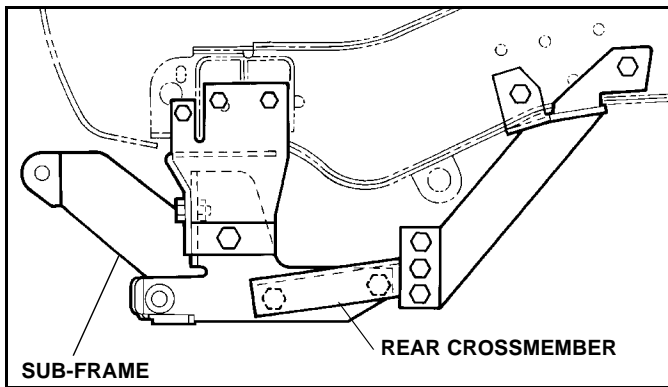

TORQUE SPECIFICATIONS FOR STANDARD MACHINE HARDWARE					
Bolt Size	GR.2 Dry	GR.5 Dry	GR.8 Dry	Metric Size	GR.8.8 Dry
1/4"	66*	9	12	M8	17
5/16"	11	17	25	M10	35
3/8"	20	30	45	M12	60
7/16"	32	50	70	M14	95
1/2"	50	75	110	M16	155
9/16"	70	110	150		
5/8"	100	150	220		
3/4"	175	260	380		
7/8"	170	430	600		
1"	250	640	900		

Note: These torque values are to be used for all hardware. Unless otherwise specified, all torque values must meet this specification.  
 Note: All torque values are in Ft.-Lbs unless otherwise stated  
 Note: \*In-Lbs

**IMPORTANT:** Height from the center of the lower Plow Mounting holes on the Sub-Frame to the ground should be between 9" and 11" to insure proper operation.

**NOTE:** If height is less than 9" an air-adjustable suspension kit or other lift accessory must be installed to increase the height to the specifications shown.

**REMEMBER** After 5 to 10 hours of snowplow usage, re-torque all capscrews!

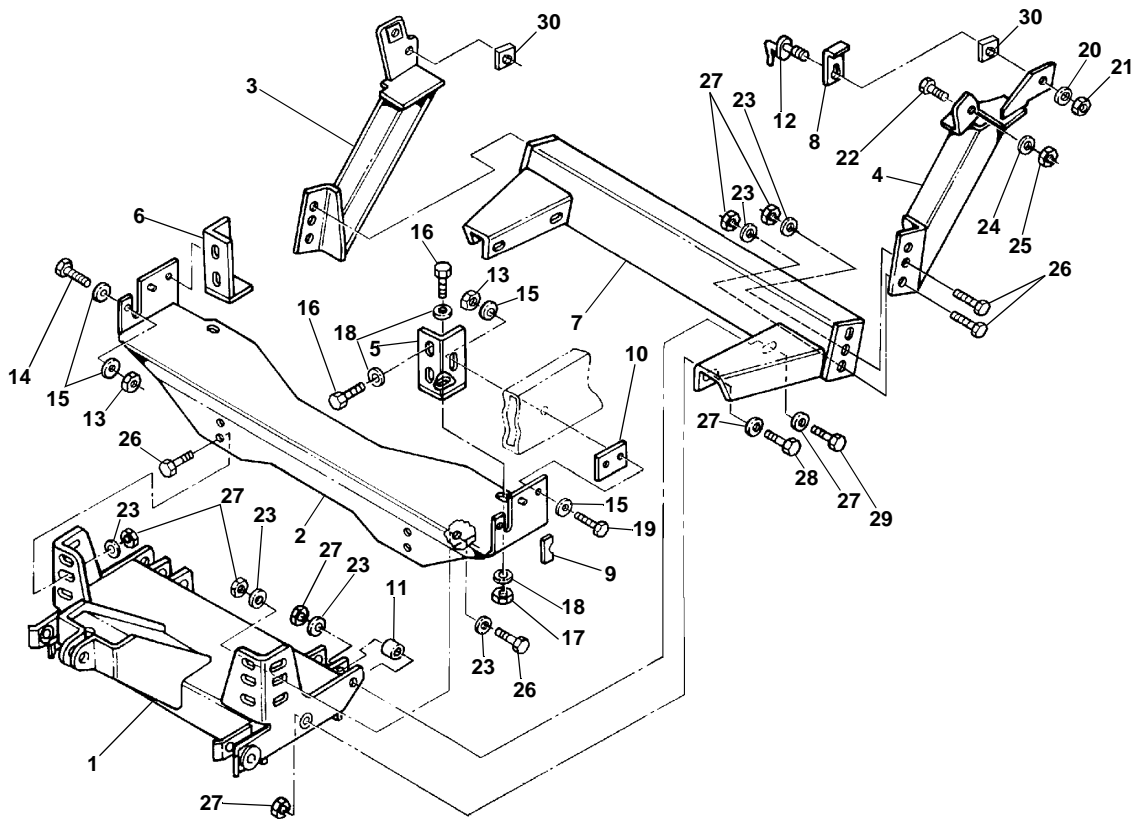

ITEM	PART NO.	DESCRIPTION	QTY.
1	96100694	Sub-Frame, Nose Piece (96100294) .....	1
2	96001657	Bracket, Mounting, Subframe .....	1
3	96001633	Bracket, Side, RH .....	1
4	96001638	Bracket, Side, LH.....	1
5	96001655	Support, Corner LH.....	1
6	96001661	Support, Corner RH.....	1
7	96100650	Crossmember, Rear .....	1
8	96001642	Retainer, Special .....	2
9	96001644	Shim .....	2
10	96001645	Shim .....	2
11	96001656	Spacer .....	2
12	96100623	Bolt, Special.....	2
13	98009013	Nut, Hex, 1/2"-13 NC Nylock .....	6
14	98009216	Capscrew, Hex Head, 1/2"-13 NC x 1-1/2" .....	4
15	98009011	Washer, Flat, 1/2" .....	8
16	98009034	Capscrew, Hex Head, 3/8"-16 NC x 1-1/4" .....	6
17	98009009	Nut, Hex, 3/8" - 16NC .....	6
18	98009032	Washer, Flat, 3/8" .....	12
19	98009195	Capscrew, Hex Head, 1/2"-13 NC x 4" .....	2
20	98009002	Washer, Lock, 3/4".....	2
21	98009075	Nut, Hex, 3/4"-10 NC .....	2
22	98009111	Capscrew, Hex Head, 5/8"-11 NC x 4-1/2" .....	2
23	98009039	Washer, Flat, 5/8" .....	14
24	98009062	Washer, Lock 5/8".....	2
25	98009078	Nut, Hex, 5/8" - 11NC .....	2
26	98009115	Capscrew, Hex Head, 5/8"-11 NC x 1-1/2" .....	8
27	98009038	Nut, Hex, 5/8" - 11NC Nylock, .....	12
28	98009042	Capscrew, Hex Head, 5/8"-11 NC x 3-1/2" .....	2
29	98009217	Capscrew, Hex Head, 5/8"-11 NC x 3" .....	2
30	96102702	Spacer .....	2



SNO-WAY INTERNATIONAL, INC.