



# **Assembly & Installation Instructions**

**FOR  
SUBFRAME COMPONENTS PACKAGE 99100280  
AND  
SUBFRAME NOSE PIECE PACKAGE 96103001  
TO FIT**

**1995 & LATER TOYOTA TACOMA 4x4  
1996 & LATER TOYOTA FORERUNNER 4x4**

97100426C



1. **THINK SAFETY, ALWAYS WEAR SAFETY GLASSES WHEN PERFORMING THE OPERATIONS PRESCRIBED IN THESE INSTRUCTIONS**
2. **READ ALL INSTRUCTIONS CAREFULLY BEFORE ATTEMPTING INSTALLATION**
3. **BEFORE BEGINNING WORK MAKE SURE TO SET PARKING BRAKE AND CHOCK WHEELS**



### MINIMUM VEHICLE RECOMMENDATIONS

Heavy Duty Alternator                      Heavy Duty Battery

*NOTE: On some vehicles it may be necessary to use a form of load booster to decrease the vehicle's front suspension sag with the snow plow in place. This can be accomplished with the use of supplementary air bags, booster springs, or similar load boosting devices. Since there are different load boosting devices available, it will up to the customer/end user to decide and purchase the product to suit the application, and not the responsibility of Sno-Way International, Inc.*

### ASSEMBLY TOOLS NEEDED

Drill Bits	1/4" - 17/32"
Impact Sockets	7/16" – 1-3/8"
Metric Sockets	10 - 19 mm
Wrenches	7/16" – 1-3/8"
Metric Wrenches	10 - 19 mm
Torque Wrench	
Center Punch and Hammer	
Clamping Device ("C" Clamp, Bar Clamp, type device...)	
Hacksaw	
Alignment Pry Bar	

### INSTALLATION NOTES

1. **Unless otherwise specified, mount all Sub-Frame Components to vehicle before tightening any hardware.**
2. **It is recommended that LOCTITE®, or similar thread locking product, be used on ALL mounting hardware (i.e. Nuts, Cap Screws, Bolts, etc.).**
3. Vehicle should be parked on a level surface with a normal vehicle load on the FRONT suspension.
4. Items in parentheses ( ) refer to quantity required for this step. Items in parentheses with a pound sign (#) indicate the part number as found in the parts list on the last page of this document. Example: (2) 5/8" x 1-1/2" Cap Screws (#4)
5. It may be necessary to relocate license plate holder. Check state and local laws for placement, if needed.

### MOUNTING INSTRUCTIONS

1. Remove splash guard and tow hook(s) if equipped. Retain, with mounting hardware, for future use if plow Sub-Frame is removed.

*NOTE: Some vehicles will need to use the set of holes located toward the center of the Rear Crossmember.*

2. Align (1) Rear Crossmember (#3) mounting holes with existing holes centered in vehicle crossmember. Secure using (2) 1/2" x 4-1/2" Cap Screws (#8), (2) Flat Washers (#5), (2) 1/2" Flat Washers (#9), and (2) 1/2" Nylock Nuts (#10).

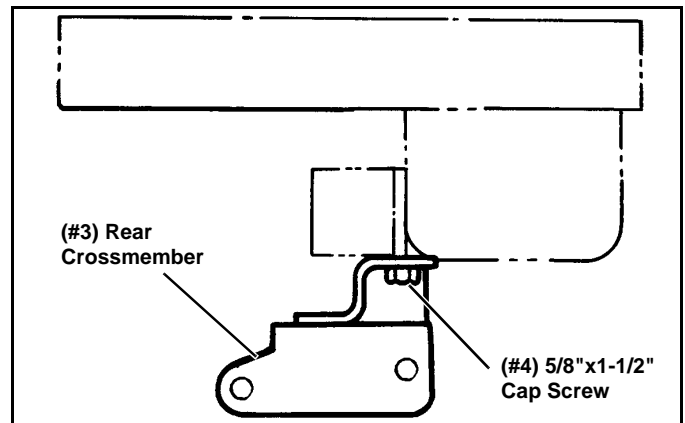

3. Mount (1) Front Crossmember (#2) on (1) Sub-Frame (#1). Secure using (4) 5/8" x 1-1/2" Cap Screws (#4), (4) 5/8" Flat Washers (#5), and (4) 5/8" Nylock Nuts (#6). Using the Torque Specification Chart, torque all Cap Screws to required specification.

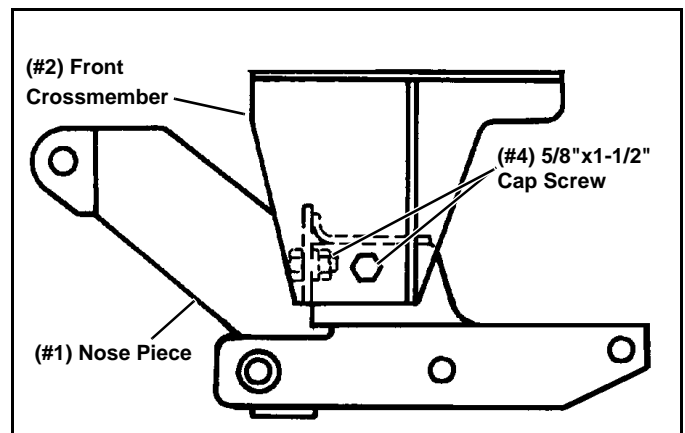

**IMPORTANT:** To insure proper operation of equipment, the height from the center of the lower front Plow Mounting holes to the ground should be between 9" and 11".

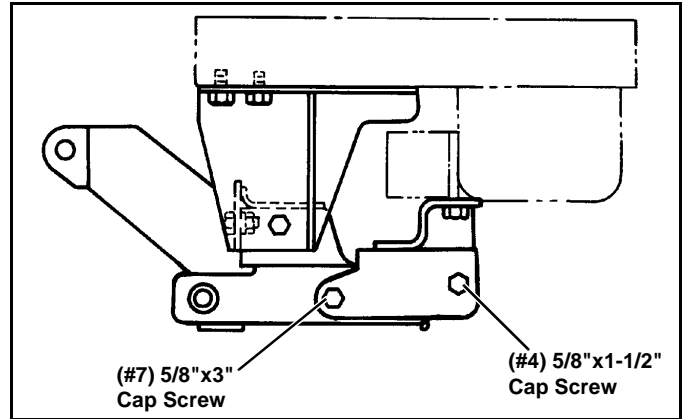
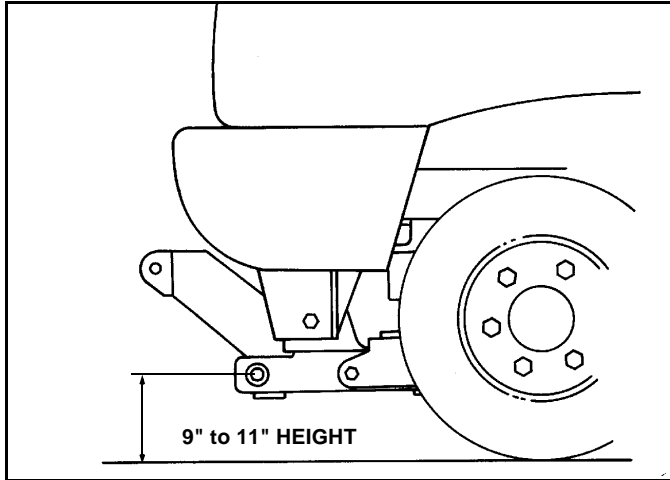

6. Starting at the Rear Crossmember and working forward, using the Torque Specification Chart, torque all mounting hardware to the required specification. (See Install Notes #1 & #2.)

4. Align Front Crossmember assembly mounting holes, (from step #3) with former tow hook holes and secure using (4) M12-1.25 x 40 Metric Cap Screws (#11). (See Install Notes #1 & #2.)

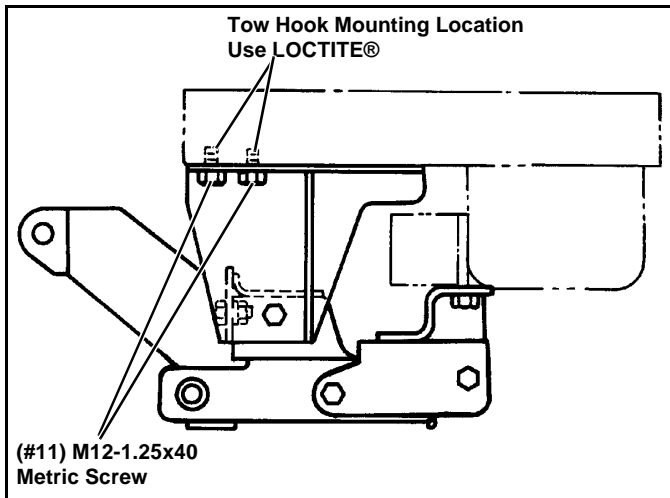

TORQUE SPECIFICATIONS FOR STANDARD MACHINE HARDWARE					
Bolt Size	GR.2 Dry	GR.5 Dry	GR.8 Dry	Metric Size	GR.8.8 Dry
1/4"	66*	9	12	M8	17
5/16"	11	17	25	M10	35
3/8"	20	30	45	M12	60
7/16"	32	50	70	M14	95
1/2"	50	75	110	M16	155
9/16"	70	110	150		
5/8"	100	150	220		
3/4"	175	260	380		
7/8"	170	430	600		
1"	250	640	900		

Note: These torque values are to be used for all hardware. Unless otherwise specified, all torque values must meet this specification.  
 Note: All torque values are in Ft.-Lbs unless otherwise stated  
 Note: \*In-Lbs

5. Align Rear Crossmember mounting holes with Front Crossmember Assembly mounting holes and secure as follows:

- Front Mounting- use (2) 5/8" x 3" Cap Screws (#7) and (2) 5/8" Nylock Nuts (#6).
- Rear Mounting - use (2) 5/8" x 1-1/2" Cap Screws (#4) and (2) 5/8" Nylock Nuts (#6).

**REMEMBER** After 5 to 10 hours of snowplow usage, re-torque all Cap Screws!

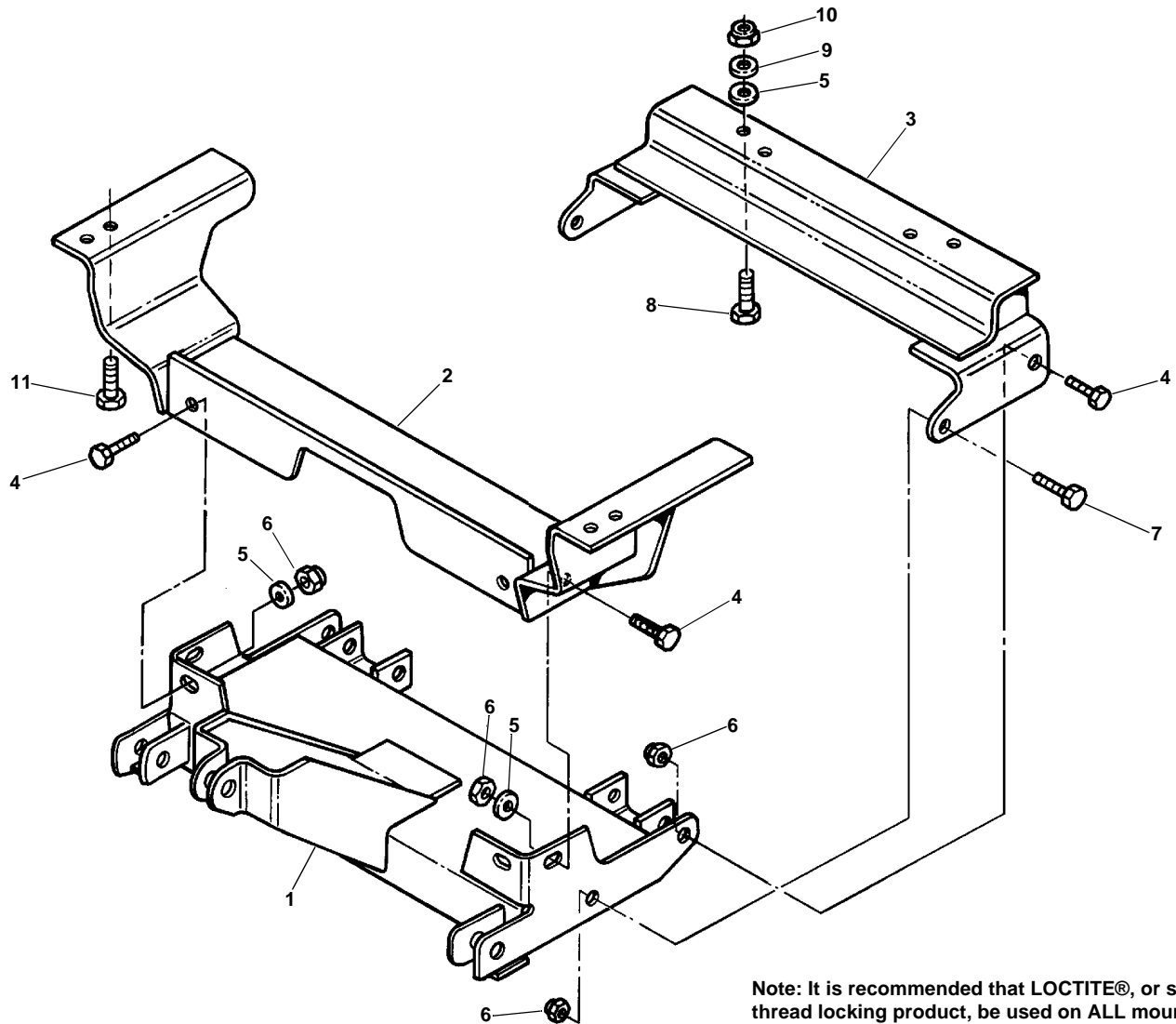

Note: It is recommended that LOCTITE®, or similar thread locking product, be used on ALL mounting hardware (i.e. Nuts, Cap Screws, Bolts, etc.).

ITEM	PART NO.	DESCRIPTION	QTY.
1	96103001	Sub-Frame, Nose Piece (96102924) .....	1
2	96102331	Crossmember, Front.....	1
3	96102332	Crossmember, Rear .....	1
4	98009115	Cap Screw, Hex Head, 5/8"-11NC x 1-1/2" .....	6
5	98009039	Washer, Flat, 5/8" .....	6
6	98009038	Nut, Hex, 5/8"-11 NC Nylock .....	8
7	98009217	Cap Screw, Hex Head, 5/8"-11NC x 3".....	2
8	98009055	Cap Screw, Hex Head, 1/2"-13NC x 4-1/2" .....	2
9	98009011	Washer, Flat, 1/2" .....	2
10	98009013	Nut, Hex, 1/2"-13 NC Nylock .....	2
11	98009054	Cap Screw, Metric Hex Head, M12-1.25 x 40.....	4

SNO-WAY® INTERNATIONAL, INC.



©1999 Sno-Way® International