



Assembly & Installation Instructions

**FOR
SUBFRAME COMPONENTS PACKAGE 99100287
AND
SUBFRAME NOSE PIECE PACKAGE 96103002**

**TO FIT
1991 & LATER FORD 4X4 EXPLORER
1992 FORD RANGER
1994 MAZDA B3000 & B4000 4X4 PICKUP**

97100473C



1. THINK SAFETY, ALWAYS WEAR SAFETY GLASSES WHEN PERFORMING THE OPERATIONS PRESCRIBED IN THESE INSTRUCTIONS
2. READ ALL INSTRUCTIONS CAREFULLY BEFORE ATTEMPTING INSTALLATION
3. BEFORE BEGINNING WORK MAKE SURE TO SET PARKING BRAKE AND CHOCK WHEELS

MINIMUM VEHICLE RECOMMENDATIONS

Heavy Duty Alternator
Heavy Duty Battery

ASSEMBLY TOOLS NEEDED

Drill Bits 1/4", 21/32"
Impact Sockets 7/16" – 1-3/8"
Wrenches 7/16" – 1-3/8"
Torque Wrench
Hammer and Center Punch
Two 6" C-Clamps

INSTALLATION NOTES

1. Unless specified, mount all Sub-Frame Components to vehicle before tightening any bolts.
2. Vehicle should be parked on a level surface with the front suspension normally loaded.

MOUNTING INSTRUCTIONS

1. Remove air dam from vehicle, retain with mounting hardware for future use if Plow Sub-Frame is removed.

NOTE: Air dam may be used with Plow by cutting dam to allow clearance for nose of Sub-Frame. To modify air dam measure 2-7/8" from each side of center and remove a 5-3/4" deep section from between the marked areas.

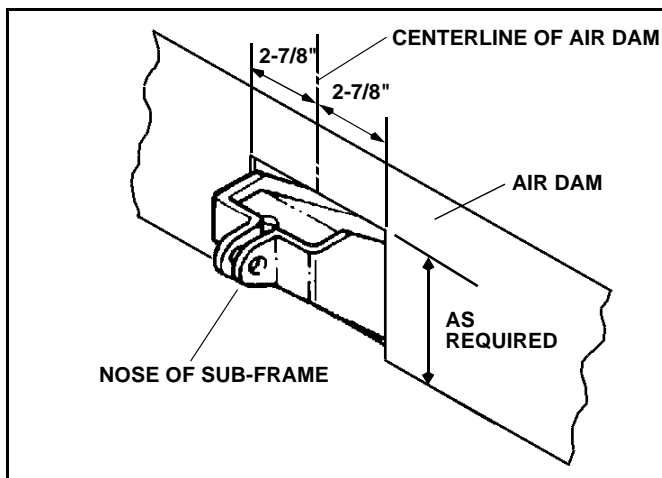

2. Relocate license plate holder if required to clear Sub-Frame Assembly.

For Mazda and Explorer Only:

3. Install Front Crossmember (#96102508) utilizing existing triangular holes in vehicle frame below radiator, locating the Crossmember's rear mounting holes directly below the rubber anti-vibration body mounts. Insert Shims (#96100552) between frame and Front Crossmember as needed. Additional Shims may be needed between frame and Front Crossmember. Secure using two (2) 5/8" x 4 1/2" Capscrews (#98009111), and Nylock Nuts provided in two rear holes, and two (2) 1/2" x 4 1/2" Capscrews (#98009055), Flat Washers (#98009011), and Nylock Nuts provided. Snug Capscrews to hold Front Crossmember against frame, Do Not Tighten Fully At This Time. Locate two (2) 3/8" Hex Nuts (#98009077) and thread on to the two (2) 3/8" x 2" Capscrews (#98009058) and insert into weld nuts in Front Crossmember. Tighten to 30 Ft.Lbs. Tighten Hex Nut against Front Crossmember to 30 Ft. Lbs.

For Ranger Only:

3. Install Front Crossmember (#96100631) utilizing existing triangular holes in vehicle frame below radiator, locating the Crossmember's front mounting holes directly below the rubber anti-vibration body mounts. Insert Shims (#96100552) between frame and Front Crossmember as needed. Additional Shims may be needed between frame and Front Crossmember. Insert two (2) 5/8" x 4 1/2" Capscrews (#98009111), and two (2) 1/2" x 4 1/2" Capscrews (#98009055), and secure with Nylock Nuts provided. Snug Capscrews to hold Front Crossmember against frame, Do Not Tighten Fully At This Time. Locate two (2) 3/8" Hex Nuts (#98009077) and thread on to the two (2) 3/8" x 2" Capscrews (#98009058) and insert into weld nuts in Front Crossmember. Tighten to 30 Ft.Lbs. Tighten Hex Nut against Front Crossmember to 30 Ft. Lbs.

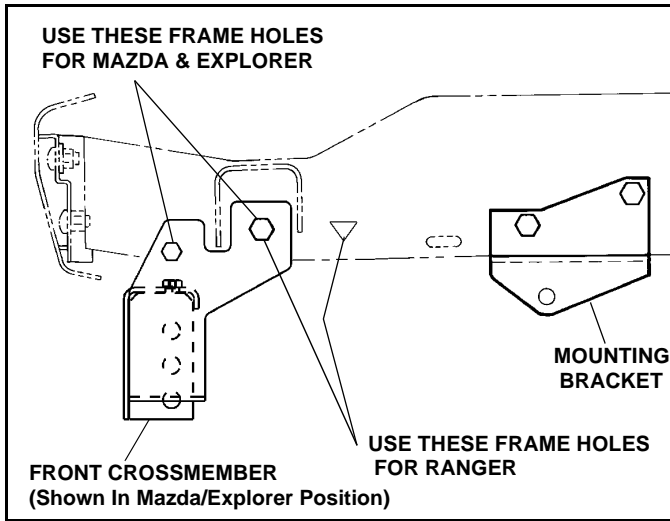

4. Remove two lowest bolts from the vehicle's power steering gear box located in front of the left front coil spring. Install Mounting Brackets (#96100459)LH utilizing the existing hardware removed from gear box. Re-torque to factory specifications.

NOTE: It is recommended that LOCTITE® or similar thread locking material be used when reinstalling the gear box hardware.

CAUTION

Beware of brake and fuel lines secured to inside wall of frame rails when performing Step 5.

5. On passenger side of vehicle, remove nut from vertically positioned bolt located in frame tube approximately eight inches (8") behind the sway bar mount. This bolt fastens the vehicle crossmember to the frame. Align Mounting Bracket (#96100357)RH and fasten with original hardware. Using bracket as a template, drill a 1/4" pilot hole then drill to 21/32" through the inner wall of vehicle frame and secure with 5/8" x 4-1/2" Capscrew (#98009111), Washer and Nylock Nut provided.

TORQUE SPECIFICATIONS FOR STANDARD MACHINE HARDWARE

Bolt Size	GR.2 Dry	GR.5 Dry	GR.8 Dry	Metric Size	GR.8.8 Dry
1/4"	66*	9	12	M8	17
5/16"	11	17	25	M10	35
3/8"	20	30	45	M12	60
7/16"	32	50	70	M14	95
1/2"	50	75	110	M16	155
9/16"	70	110	150		
5/8"	100	150	220		
3/4"	175	260	380		
7/8"	170	430	600		
1"	250	640	900		

Note: These torque values are to be used for all hardware. Unless otherwise specified, all torque values must meet this specification.

Note: All torque values are in Ft.-Lbs unless otherwise stated

Note: *In-Lbs

- Raise front of Sub-Frame Assembly (#96100294) and align mounting holes in Front Crossmember. Secure using four (4) 5/8" x 1-1/2" Capscrews (#98009115), Washers and Nylock Nuts provided.
- Install Adjustable Support Link between Mounting Brackets and between rear mounting ears on Sub-Frame Assembly as shown. Secure to Sub-Frame using 5/8" x 4" Capscrews (#98009194) and Nylock Nuts provided. Secure to lower hole in Mounting Brackets using 5/8" x 3-1/2" Capscrews (#98009042), Spacers (#96100548) and Nylock Nuts provided.

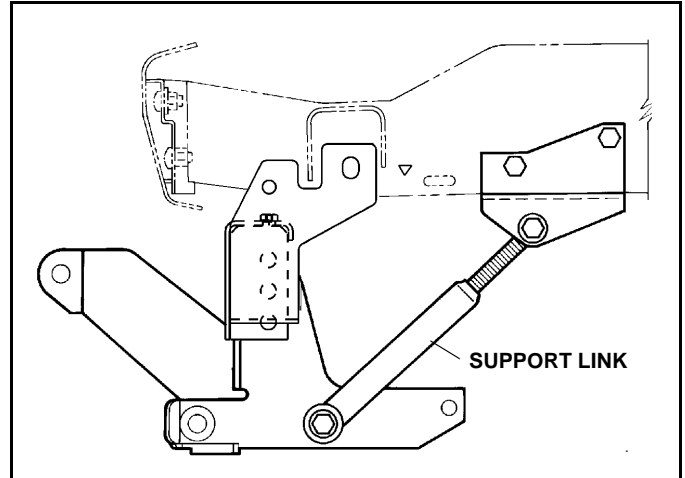

- Adjust Support Link until Sub-Frame is level with ground.
- Using the Torque Specification chart, torque all Capscrews starting at the rear and working forward.

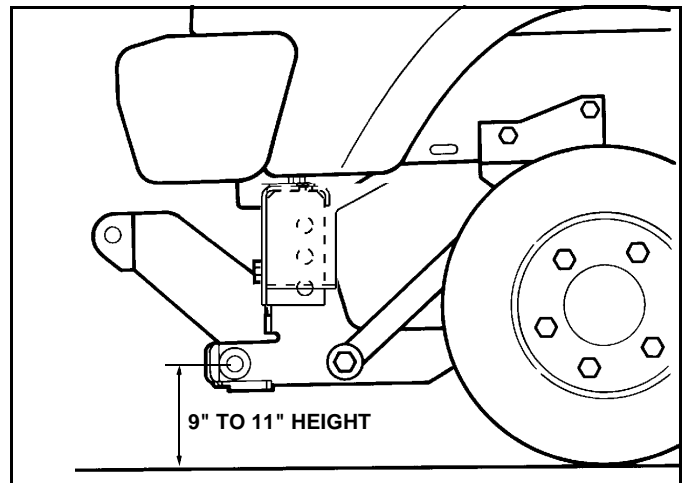

IMPORTANT: Height from the center of the lower Plow Mounting holes on the Sub-Frame to the ground should be between 9" and 11" to insure proper operation.

REMEMBER After 5 to 10 hours of snowplow usage, re-torque all capscrews!

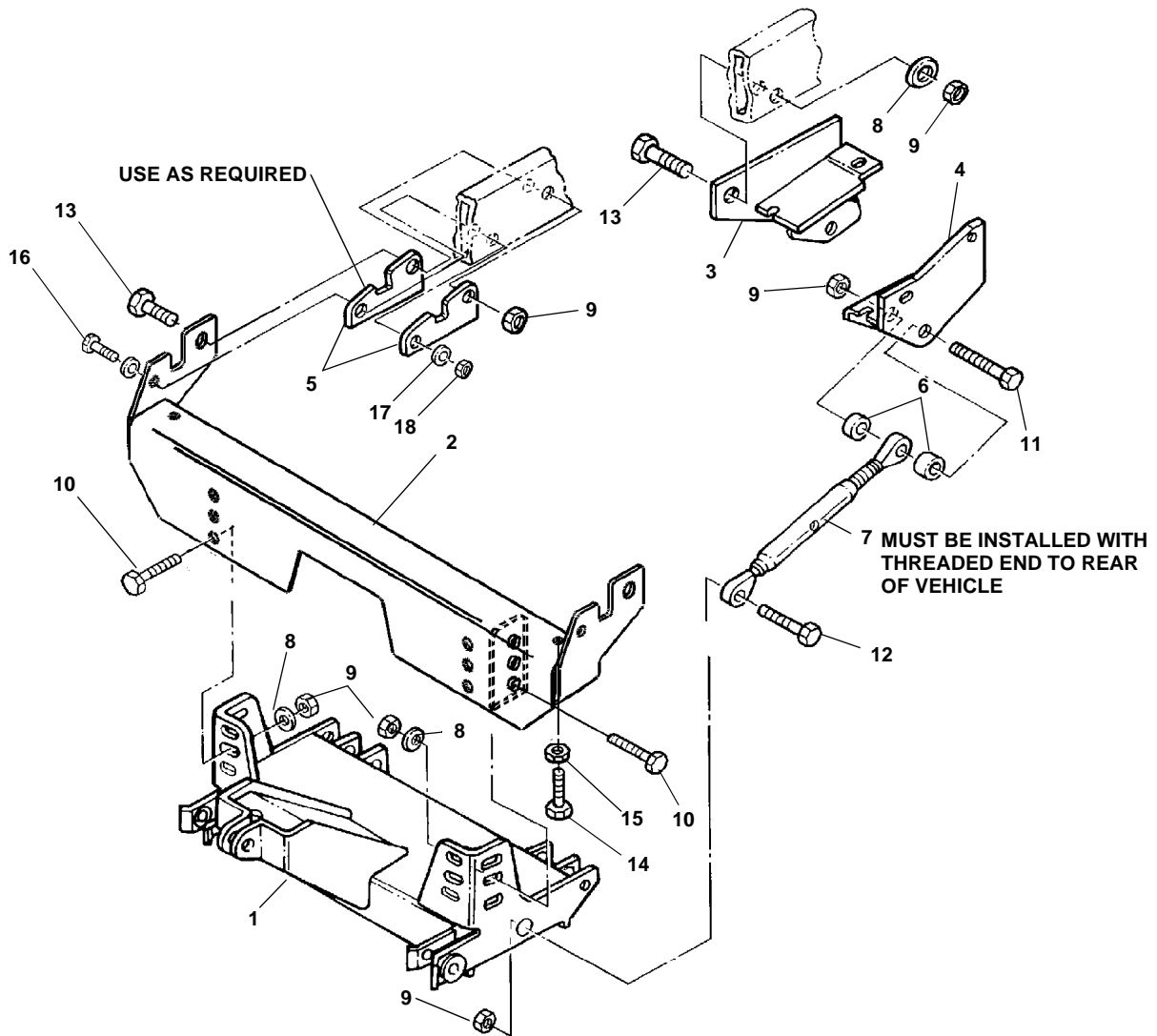

ITEM	PART NO.	DESCRIPTION	QTY.
1	96103002	Sub-Frame, Nose Piece (96102896)	1
2	96102508	Crossmember, Front	1
3	96100357	Bracket, Rear Mounting, RH	1
4	96100459	Bracket, Rear Mounting, LH.....	1
5	96100552	Shim.....	6
6	96100548	Spacer	4
7	96001831	Link, Adjustment	2
8	98009039	Washer, Flat, 5/8"	5
9	98009038	Nut, Hex, 5/8" - 11 NC Nylock,.....	11
10	98009115	Cap screw, Hex Head, 5/8"-11 NC x 1-1/2"	4
11	98009042	Cap screw, Hex Head, 5/8"-11 NC x 3-1/2"	2
12	98009194	Cap screw, Hex Head, 5/8"-11 NC x 4".....	2
13	98009111	Cap screw, Hex Head, 5/8"-11 NC x 4-1/2"	3
14	98009058	Cap screw, Hex Head, 3/8"-16 NC x 2"	2
15	98009077	Nut, Hex, 3/8" - 16 NC	2
16	98009055	Cap screw, Hex Head, 1/2"-13 NC x 4-1/2"	2
17	98009011	Washer, Flat, 1/2"	4
18	98009013	Nut, Hex Head, 1/2" - 13 NC	2



SNO-WAY INTERNATIONAL, INC.