



Assembly & Installation Instructions

**FOR
SUBFRAME COMPONENTS PACKAGE 99100301
AND
SUBFRAME NOSE PIECE PACKAGE 96103001**

**TO FIT
1997 & LATER JEEP TJ WRANGLER 4x4**

97100518B



1. **THINK SAFETY, ALWAYS WEAR SAFETY GLASSES WHEN PERFORMING THE OPERATIONS PRESCRIBED IN THESE INSTRUCTIONS**
2. **READ ALL INSTRUCTIONS CAREFULLY BEFORE ATTEMPTING INSTALLATION**
3. **BEFORE BEGINNING WORK MAKE SURE TO SET PARKING BRAKE AND CHOCK WHEELS**



MINIMUM VEHICLE RECOMMENDATIONS

Heavy Duty Alternator Heavy Duty Battery
 Heavy Duty Suspension

ASSEMBLY TOOLS NEEDED

Sockets	7/16" – 1-1/8"
Wrenches	7/16" – 1-1/8"
Torque Wrench	
Torx Head Bit	T55

NOTE: It will be necessary to use a form of load booster to decrease the vehicle's front suspension sag with the snow plow in place. This can be accomplished with the use of supplementary air bags, booster springs, or similar load boosting devices. Since there are different load boosting devices available, it will up to the customer/end user to decide and purchase the product to suit the application, and not the responsibility of Sno-Way International, Inc.

INSTALLATION NOTES

1. Unless otherwise specified, mount all Sub-Frame Components to vehicle before tightening any hardware.
2. It is recommended that **LOCTITE®**, or similar thread locking product, be used on **ALL** mounting hardware (i.e. Nuts, Cap Screws, Bolts, etc.).
3. Vehicle should be parked on a level surface with a normal vehicle load on the **FRONT** suspension.
4. Items in parentheses () refer to quantity required for this step. Items in parentheses with a pound sign (#) indicate the part number as found in the parts list on the last page of this document.
 Example: (2) 5/8" x 11 x 1-1/2" Cap Screws (#10).
5. It may be necessary to relocate license plate holder. Check state and local laws for placement, if needed.

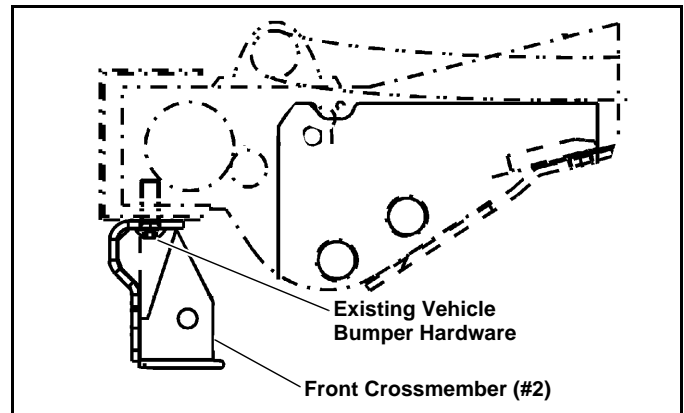

3. Insert hook end of Special Bolts (#7) into slots directly below stabilizer bar, and on bottom of frame rail, in line with radiator shroud, on both driver and passenger sides. Use Special Retainer (#6) to hold Special Bolts (#7) in place, to prevent them from falling inside vehicle frame.

MOUNTING INSTRUCTIONS

1. Remove vehicle bumper mounting hardware from bottom side of bumper.
2. Align slotted mounting holes in top of Front Crossmember (#2) with bumper mounting holes. Place (1) Flat Washer (#12) on each bolt removed in step 1 and use to secure Front Crossmember to vehicle frame.

*NOTE: It is recommended that **LOCTITE®** or similar thread locking material be used when re-installing vehicle hardware used in step 2.*

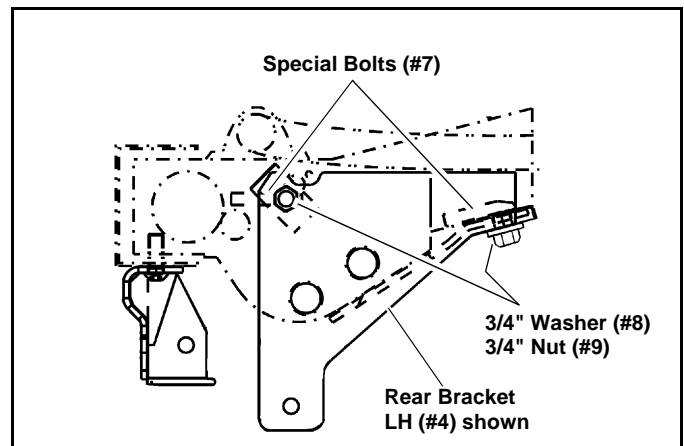

4. Install Left and Right Rear Mounting Brackets (#4 L.H. & #5 R.H.) over Special Bolts (#7) and secure using 3/4" Lock Washer (#8) and 3/4"-10 Nuts (#9).
5. Mount Rear Crossmember (#3) to Sub-Frame (#1) using (2) 5/8" x 1-1/2" Cap Screws (#10) in rear holes and (2) 5/8" x 3-1/2" Cap Screws (#11) in forward holes. Secure with Flat Washers (#12), and Nylock Nuts (#13).

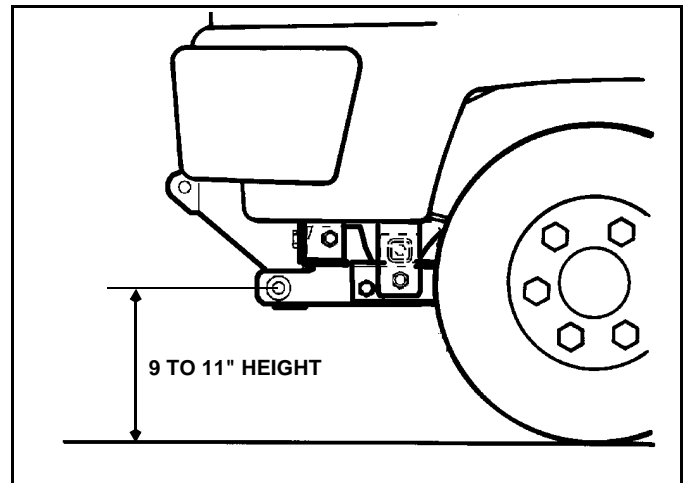
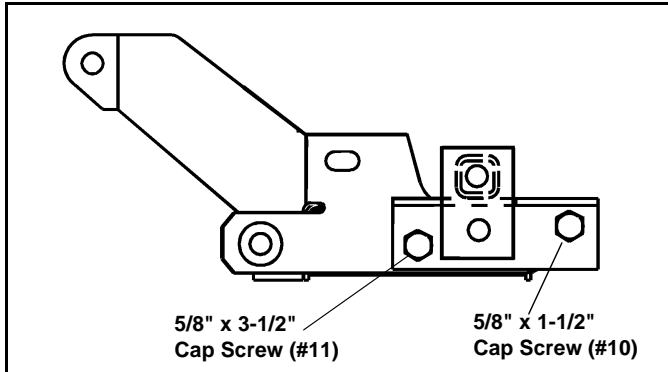

IMPORTANT: Height from the center of the lower Plow Mounting holes on the Sub-Frame to the ground should be between 9" and 11" to insure proper operation.

6. Raise assembly from step 5 and align slotted holes in Sub-Frame (#1) with holes in Front Crossmember (#2). Secure using (4) 5/8" x 1-1/2" Cap Screws (#10), Flat Washers (#12) and Nylock Nuts (#13).

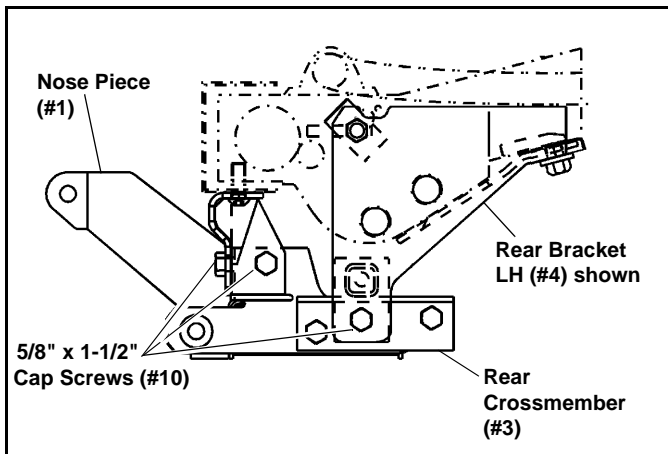

TORQUE SPECIFICATIONS FOR STANDARD MACHINE HARDWARE					
Bolt Size	GR.2 Dry	GR.5 Dry	GR.8 Dry	Metric Size	GR.8.8 Dry
1/4"	66*	9	12	M8	17
5/16"	11	17	25	M10	35
3/8"	20	30	45	M12	60
7/16"	32	50	70	M14	95
1/2"	50	75	110	M16	155
9/16"	70	110	150		
5/8"	100	150	220		
3/4"	175	260	380		
7/8"	170	430	600		
1"	250	640	900		

These torque values are to be used for all hardware. Unless otherwise specified, all torque values must meet this specification.
All torque values are in Ft.-Lbs unless otherwise stated
*In-Lbs

7. Swing Rear Crossmember (#3) up to align with holes in Rear Mounting Brackets(#4 & #5), and secure using (2) 5/8" x 1-1/2" Cap Screws (#10), and Nylock Nuts (#13).
8. Keeping Sub-Frame parallel to ground, tighten all fasteners using Torque Specification Chart.

REMEMBER After 5 to 10 hours of snowplow usage, re-torque all Cap Screws!

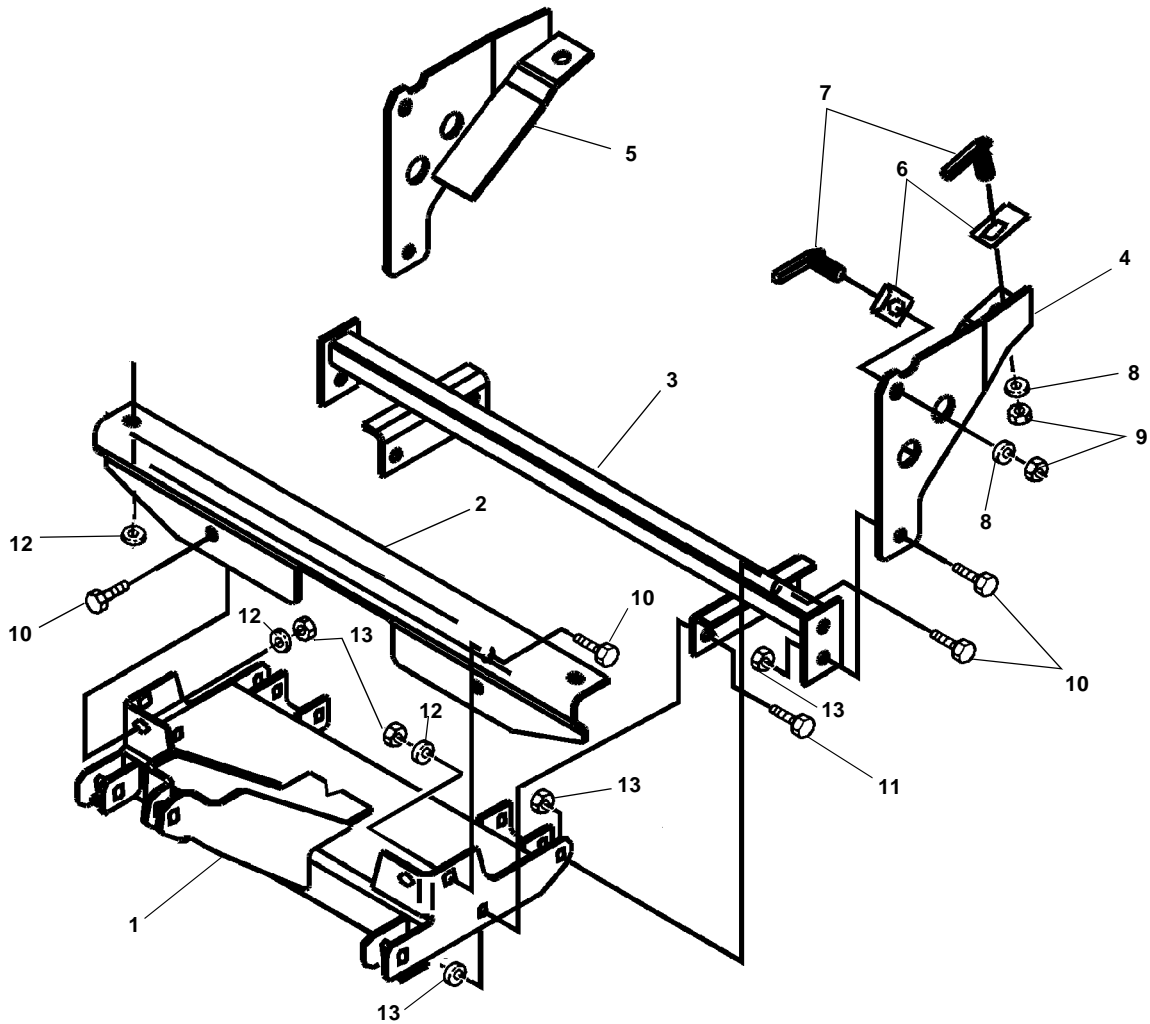

Note: It is recommended that LOCTITE®, or similar thread locking product, be used on ALL mounting hardware (i.e. Nuts, Cap Screws, Bolts, etc.).

ITEM	PART NO.	DESCRIPTION	QTY.
1	96103001	Sub-Frame, Nose Piece (96102924)	1
2	96102643	Crossmember, Front	1
3	96102651	Crossmember, Rear	1
4	96102645	Bracket, Rear, LH.....	1
5	96102648	Bracket, Rear, RH	1
6	96001642	Retainer, Special.....	4
7	96100623	Bolt, Special	4
8	98009002	Washer, Locking, 3/4"	4
9	98009075	Nut, Hex, 3/4"-10 NC	4
10	98009115	Cap Screw, Hex Head, 5/8" -11 x 1-1/2"	8
11	98009042	Cap Screw, Hex Head, 5/8" -11 x 3-1/2"	2
12	98009039	Washer, Flat 5/8".....	6
13	98009038	Nut, Hex, Nylock, 5/8" -11	10

SNO-WAY® INTERNATIONAL, INC.



©1999 Sno-Way® International