



**Assembly  
&  
Installation Instructions**

**FOR  
SUBFRAME COMPONENTS PACKAGE 99100386  
AND  
SUBFRAME NOSE PIECE PACKAGE 96103002**

**TO FIT  
1999 - FORD 4X4 F250 & F350**

97100613B



1. THINK SAFETY, ALWAYS WEAR SAFETY GLASSES WHEN PERFORMING THE OPERATIONS PRESCRIBED IN THESE INSTRUCTIONS
2. READ ALL INSTRUCTIONS CAREFULLY BEFORE ATTEMPTING INSTALLATION
3. BEFORE BEGINNING WORK MAKE SURE TO SET PARKING BRAKE AND CHOCK WHEELS

## MINIMUM VEHICLE RECOMMENDATIONS

Heavy Duty Alternator      Heavy Duty Battery

*NOTE: On some vehicles it may be necessary to use a form of load booster to decrease the vehicle's front suspension sag with the snow plow in place. This can be accomplished with the use of supplementary air bags, booster springs, or similar load boosting devices. Since there are different load boosting devices available, it will up to the customer/end user to decide and purchase the product to suit the application, and not the responsibility of Sno-Way International, Inc.*

## ASSEMBLY TOOLS NEEDED

Drill Bits	1/4", 17/32"
Impact Sockets	7/16" – 1-3/8"
Impact Sockets Metric	10mm – 19mm
Wrenches	7/16" – 1-3/8"
Wrenches Metric	10mm – 19mm
Torque Wrench	
Center Punch and Hammer	
Clamping Device ("C", Bar, type device...)	

## INSTALLATION NOTES

1. Unless otherwise specified, mount all Sub-Frame Components to vehicle before tightening any hardware.
2. It is recommended that LOCTITE®, or similar thread locking product, be used on ALL mounting hardware (i.e. Nuts, Cap Screws, Bolts, etc.).
3. Vehicle should be parked on a level surface with a normal vehicle load on the FRONT suspension.
4. Items in parentheses ( ) refer to quantity required for this step. Items in parentheses with a pound sign (#) indicate the part number as found in the parts list on the last page of this document. Example: (2) 5/8" x 1-1/2" Cap Screws (#9).
5. It may be necessary to relocate license plate holder. Check state and local laws for placement, if needed.

## MOUNTING INSTRUCTIONS

1. Unsnap rubber portion of air dam and other items, if equipped, so that the front bumper can be removed completely. Remove vehicle front bumper. Retain, with hardware, for replacement at end of installation.
2. Raise Front Crossmember (#2) to align with existing holes on either side of the tow hooks. Make sure the Crossmember fits over the frame above and below the tow hooks. Insert (4) Carriage Bolts (#8) in the square holes on the inside of the tow hooks and secure with (4) Lock Washers (#17) and (4) 1/2" Hex Nuts (#12).

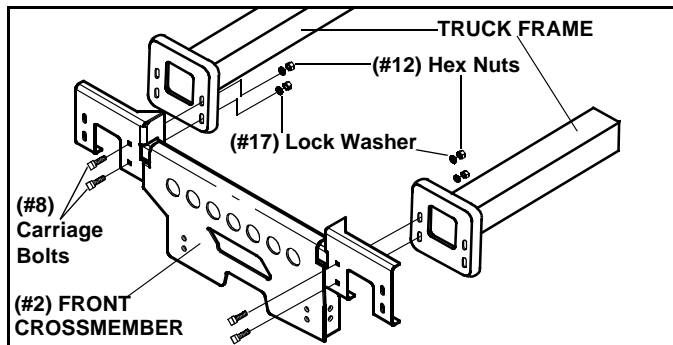

3. Install (1) Rear Crossmember (#3) on (1) Sub-Frame Nose Piece (#1):
  - Attach at front mounting holes using (2) 5/8 x 3-1/2" Cap Screws (#14) and (2) 5/8" Nylock Nuts (#11).
  - Attach at rear mounting holes using (2) 5/8 x 2" Cap Screws (#15) and (2) 5/8" nylock nuts (#11)

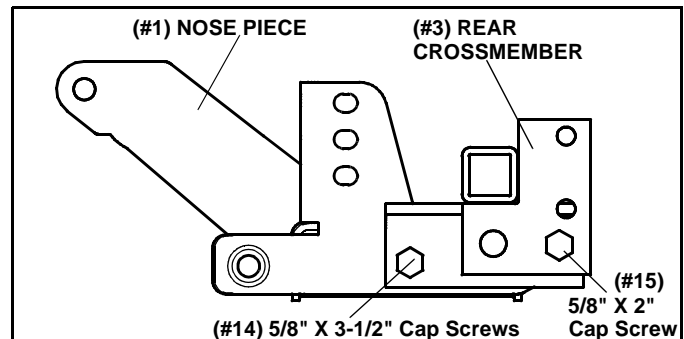

4. Raise the Sub-Frame assembly up and align with mounting holes in Front Crossmember. Secure using (4) 5/8 x 1-1/2" Cap Screws (#9), (4) 5/8" Flat Washers (#10) and (4) 5/8" Nylock Nuts (#11). Position rubber portion of the air dam under the nose piece, so that the oil cooler is not blocked.

**IMPORTANT: The Cap Screws securing the Sub-Frame to the Front Crossmember must be staggered with the front bolts being positioned in a lower set of holes than the side bolts. (Unless the holes are in the lowest possible position)**

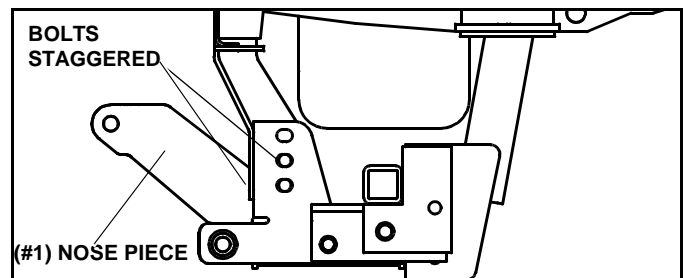

**NOTE: If bolts are installed so the nosepiece is in the highest possible position, it will be necessary to cut off the top portion of the nosepiece ears to prevent interference with the radiator and hoses.**

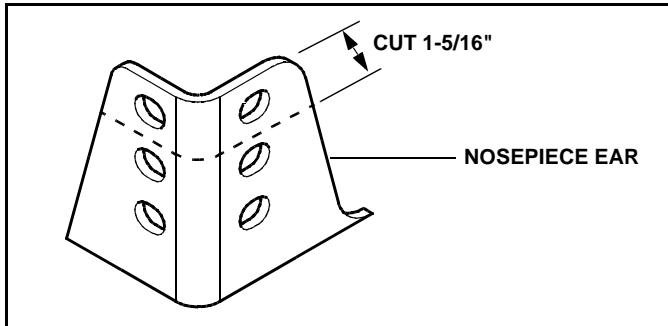

**IMPORTANT: Height from the center of the lower Plow Mounting holes on the Sub-Frame to the ground should be between 9" and 11" for Predator™ model plows, and between 9" and 12" for Lobo™ model plows to insure proper operation. On some vehicles it may be necessary to use a form of load booster (See note page 1, Minimum Vehicle Recommendations).**

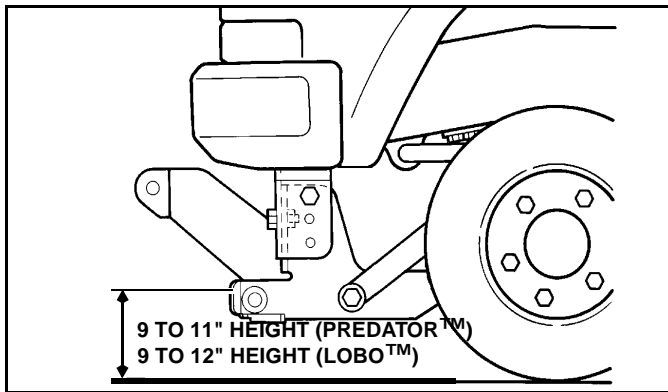

5. Assemble Rear Mounting Bracket (#4 LH & #5 RH) to Rear Crossmember with (4) 5/8 x 4-1/2" Cap Screws (#7) and Nylock Nuts (#11) provided.

**NOTE: Tighten Nuts to where the Rear Mounting Brackets and Rear Crossmember are snug to each other for proper alignment in the following steps.**



## WARNING

**Beware of brake and fuel lines secured to inside wall of frame rails when drilling holes in vehicle frame!**

**FAILURE TO HEED CAN RESULT IN SERIOUS INJURY OR DEATH!**

6. Remove rear bolt from spring bracket. Hold Rear Mounting Brackets up against bottom of vehicle frame. Secure by assembling bolt removed from spring bracket through the forward hole of Rear Mounting Brackets.

7. Using one hole on the bottom (refer to artwork on last page) and two holes on the side of Rear Mounting Brackets as a template, center punch and drill through vehicle frame member with 1/4" drill. Remove Rear Mounting Bracket and drill through vehicle frame rail using 17/32" drill.

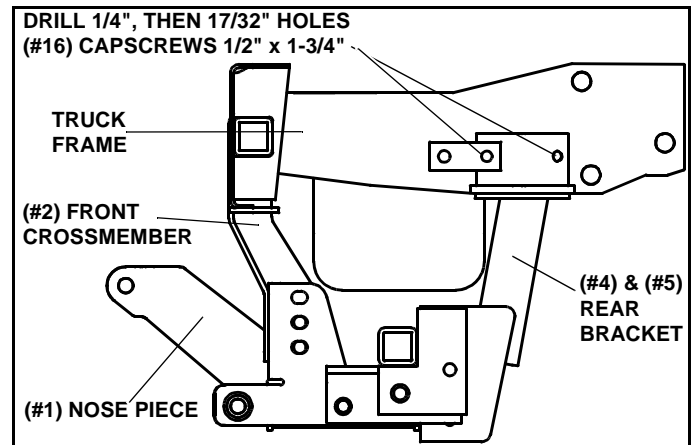

8. Insert (3) Nut Plate Assembly (#6) through the opening in front of the vehicle frame. Align the holes in (1) Nut Plate Assembly (#6) with hole drilled into the bottom of the vehicle frame, and the holes in (2) Nut Plate Assembly (#6) with the holes drilled into the side of the vehicle frame. Repeat procedure for other side of vehicle. Using (6) 1/2" x 1-3/4" Cap Screw (#16) and (6) Lock Washers (#17) secure Rear Mounting Brackets to side and bottom of vehicle frame.

9. Using the Torque Specification Chart below, torque all bolts **starting at the rear** and working forward.

TORQUE SPECIFICATIONS FOR STANDARD MACHINE HARDWARE					
Bolt Size	GR.2 Dry	GR.5 Dry	GR.8 Dry	Metric Size	GR.8.8 Dry
1/4"	66*	9	12	M8	17
5/16"	11	17	25	M10	35
3/8"	20	30	45	M12	60
7/16"	32	50	70	M14	95
1/2"	50	75	110	M16	155
9/16"	70	110	150		
5/8"	100	150	220		
3/4"	175	260	380		
7/8"	170	430	600		
1"	250	640	900		

Note: These torque values are to be used for all hardware. Unless otherwise specified, all torque values must meet this specification.  
Note: All torque values are in Ft.-Lbs unless otherwise stated  
Note: \*In-Lbs

**REMEMBER After 5 to 10 hours of snowplow usage, re-torque all Cap Screws!**

10. Reinstall bumper and all other items previously removed. Use (4) 1/2" Flat Washers (#13) on the four existing bumper screws when replacing the vehicle front bumper.

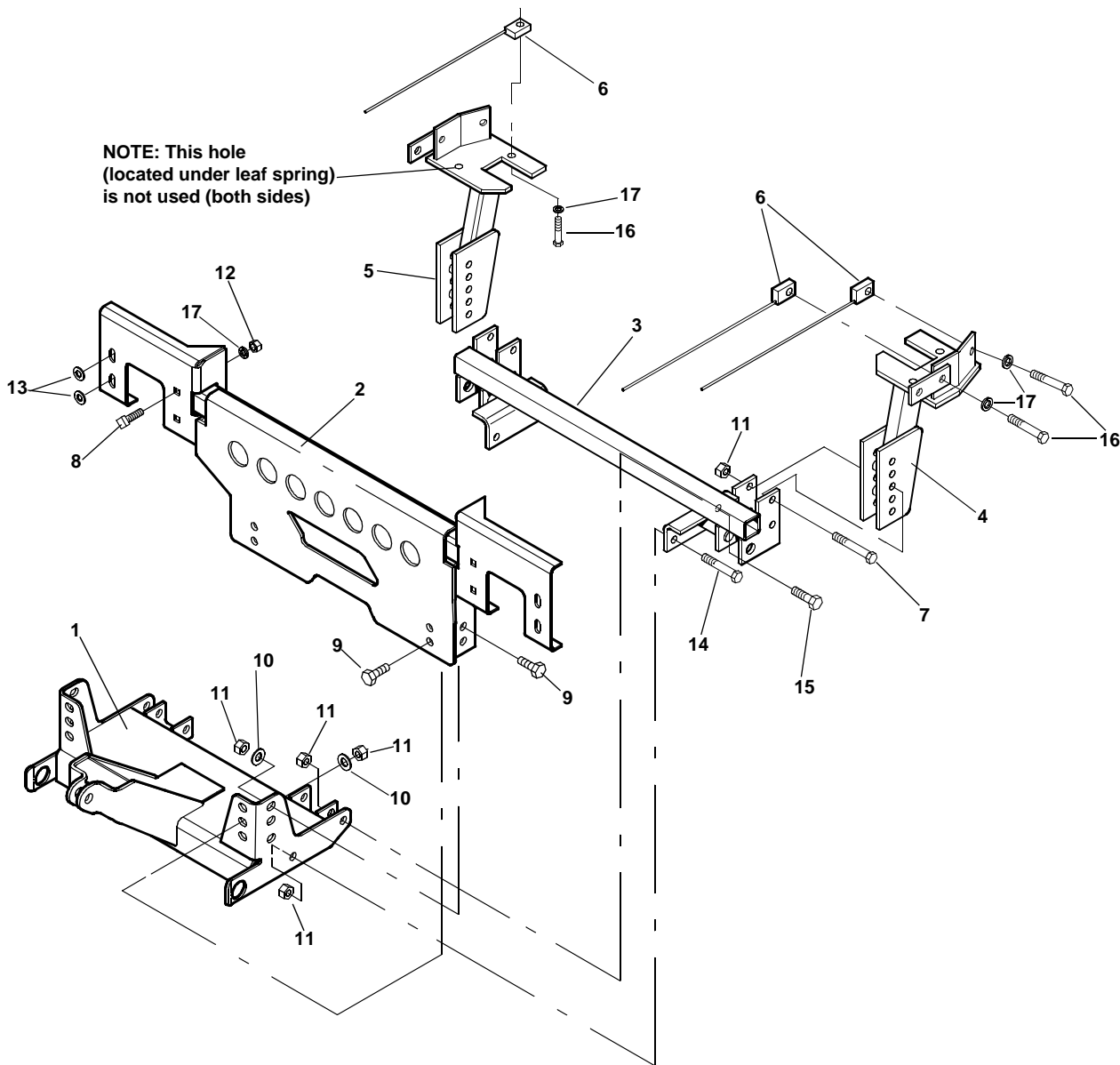

ITEM	PART NO.	DESCRIPTION	QTY.
1	96103002	Sub-Frame, Nose Piece (96102896) .....	1
2	96103373	Crossmember, Front .....	1
3	96103453	Crossmember, Rear .....	1
4	96103502	Bracket, Rear, LH .....	1
5	96103503	Bracket, Rear, RH .....	1
6	96103509	Assembly, Nut Plate .....	6
7	98009111	Cap Screw, Hex Head, 5/8" - 11 x 4-1/2" .....	4
8	98009171	Carriage Bolt, 1/2" - 13 x 1-1/2" .....	4
9	98009115	Cap Screw, Hex Head, 5/8" - 11 x 1-1/2" .....	4
10	98009039	Washer, Flat, 5/8" .....	4
11	98009038	Nut, Hex, Nylock, 5/8"-11 .....	12
12	98009076	Nut, Hex, 1/2" -13 .....	4
13	98009011	Washer, Flat, 1/2" .....	4
14	98009042	Cap Screw, Hex Head, 5/8" - 11 x 3-1/2" .....	2
15	98009041	Cap Screw, Hex Head, 5/8" - 11 x 2" .....	2
16	98100095	Cap Screw, Hex Head, 1/2" - 13 x 1-3/4" .....	6
17	98009012	Washer, Lock, 1/2" .....	10



SNO-WAY INTERNATIONAL, INC.